

### Input data

System of measurement		Metric
Input type		Coupling for electric motor
Input speed	[rpm]	1400
Output speed	[rpm]	140
Ratio (i=)		10
Frequency	[Hz]	50
Input options		IEC
Requested input power	[kW]	1.5
Service factor		1.5
Rated Power P1	[kW]	2.32

### Output data

#### Gear unit **F RT 60 B3 10 90 B14 AC 25**

Type		RT - Worm speed reducers
Input type		F (Elastic coupling)
Size		60
Ratio (i=)		10
Input flange		B14
Input speed	[rpm]	1400
Output speed	[rpm]	140
Rated output torque	[Nm]	85.95
Service Factor		1.5
Efficiency		0.84
Inertia moment	[kgm <sup>2</sup> ]	0.000119

#### Gear unit configuration

Output shaft		Hollow output shaft
Fixing		Universal
Version		B3

#### Output radial and axial loads

Ball bearings output radial load	[N]	2500
Taper bearings output radial load	[N]	3200
Ball bearings output axial load	[N]	500
Taper bearings output axial load	[N]	640

#### Accessories

Hollow output shaft		AC 25
---------------------	--	-------

#### Electric motor coupling

Size		90 L4
Poles n.		4
Power	[kW]	1.5

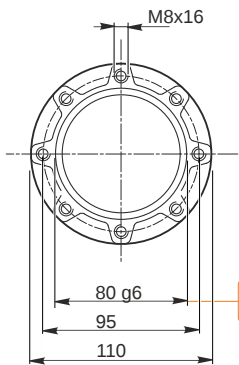
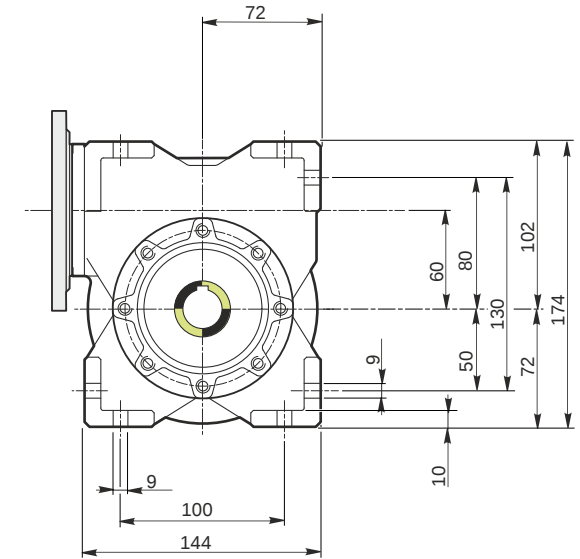
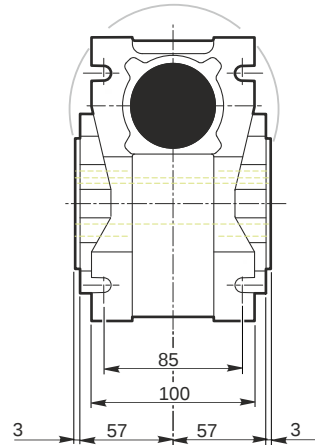
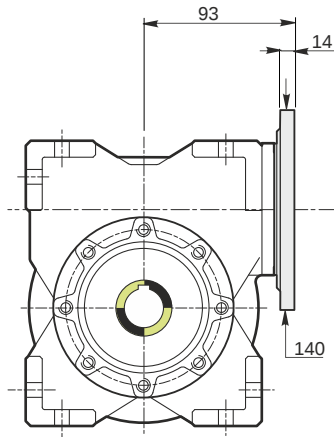

Hollow output shaft

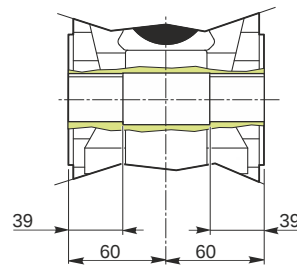
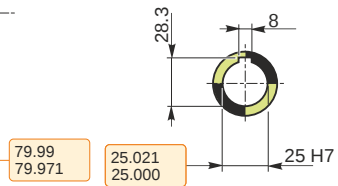

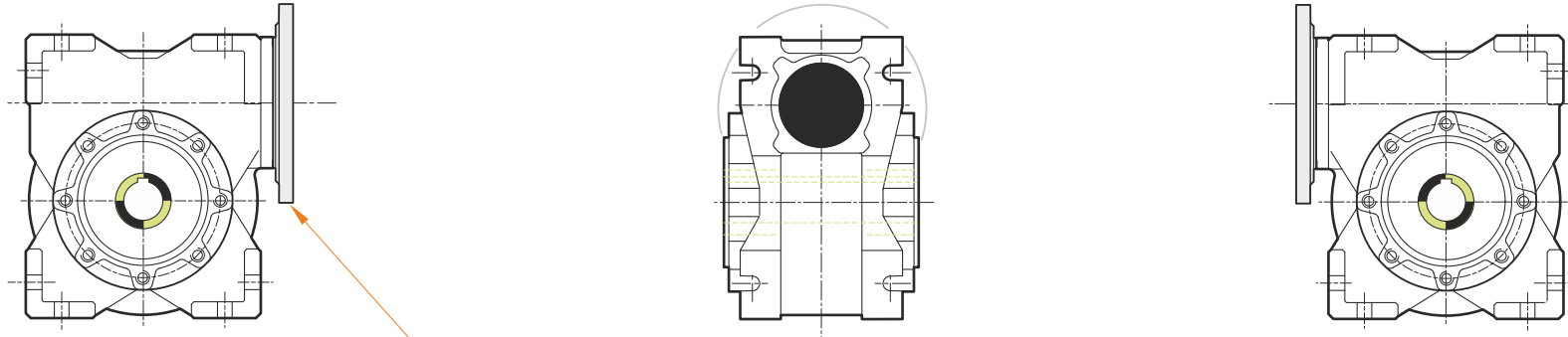

This gear unit is provided with an elastic coupling motor fitting

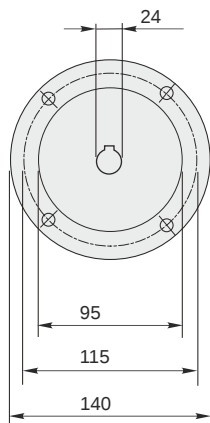

**F RT 60 B3 10 90 B14 AC 25**

### Mounting positions

B3

B6

B7

B8

V5

V6

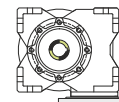
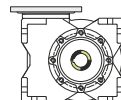
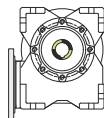
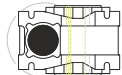
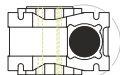
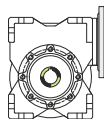

0.23



← Oil quantity [litres]

Lubricant type: Long life synthetic oil ISO VG320

### Direction of rotation

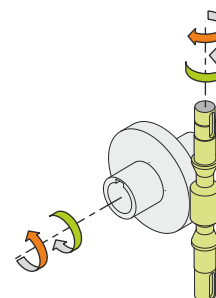
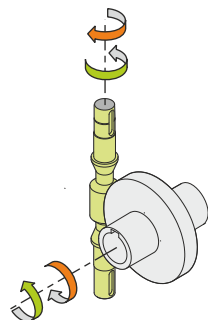
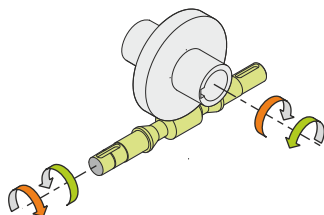
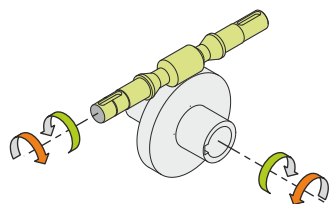

### Weight

Gear unit [kg] 6.5

### Gearing data

Axial module	3.1
Number of starts	3
Lead angle	19 °0'
Pressure angle	20°

### Backdriving

Static back-driving  
Quick back-driving  
Dynamic back-driving