

### Input data

|                       |       |                             |
|-----------------------|-------|-----------------------------|
| System of measurement |       | Metric                      |
| Input type            |       | Coupling for electric motor |
| Input speed           | [rpm] | 1400                        |
| Output speed          | [rpm] | 28.57                       |
| Ratio (i=)            |       | 49                          |
| Frequency             | [Hz]  | 50                          |
| Input options         |       | IEC                         |
| Requested input power | [kW]  | 0.18                        |
| Service factor        |       | 1.2                         |
| Rated Power P1        | [kW]  | 0.21                        |

### Output data

#### Gear unit **F RT 40 B3 49 63 B14 AC 19**

|                     |                     |                          |
|---------------------|---------------------|--------------------------|
| Type                |                     | RT - Worm speed reducers |
| Input type          |                     | F (Elastic coupling)     |
| Size                |                     | 40                       |
| Ratio (i=)          |                     | 49                       |
| Input flange        |                     | B14                      |
| Input speed         | [rpm]               | 1400                     |
| Output speed        | [rpm]               | 28.57                    |
| Rated output torque | [Nm]                | 34.9                     |
| Service Factor      |                     | 1.2                      |
| Efficiency          |                     | 0.58                     |
| Inertia moment      | [kgm <sup>2</sup> ] | 0.000018                 |

#### Gear unit configuration

|              |  |                     |
|--------------|--|---------------------|
| Output shaft |  | Hollow output shaft |
| Fixing       |  | Universal           |
| Version      |  | B3                  |

#### Output radial and axial loads

|                                   |     |      |
|-----------------------------------|-----|------|
| Ball bearings output radial load  | [N] | 1700 |
| Taper bearings output radial load | [N] | 2400 |
| Ball bearings output axial load   | [N] | 340  |
| Taper bearings output axial load  | [N] | 480  |

#### Accessories

|                     |  |       |
|---------------------|--|-------|
| Hollow output shaft |  | AC 19 |
|---------------------|--|-------|

#### Electric motor coupling

|          |      |       |
|----------|------|-------|
| Size     |      | 63 B4 |
| Poles n. |      | 4     |
| Power    | [kW] | 0.18  |

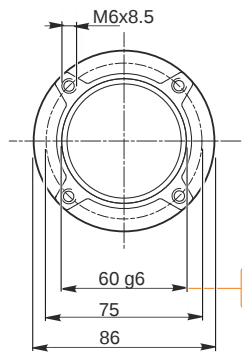
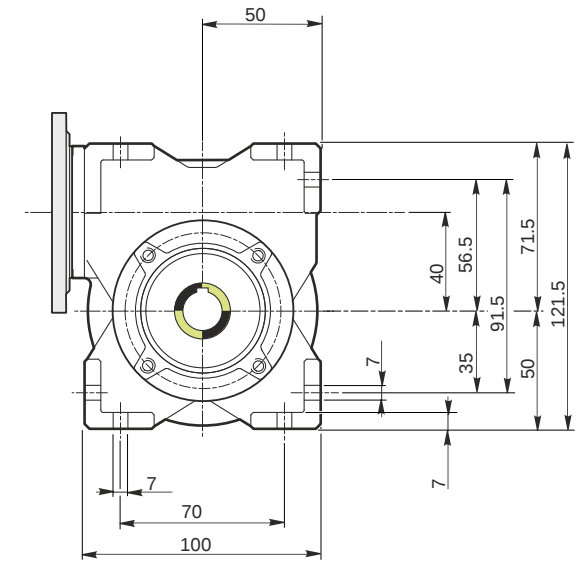
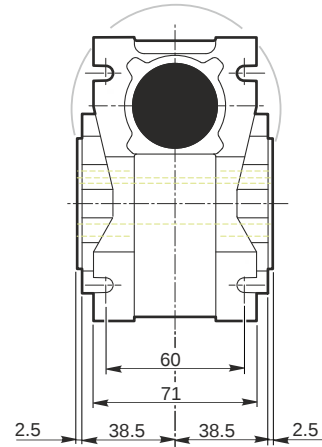
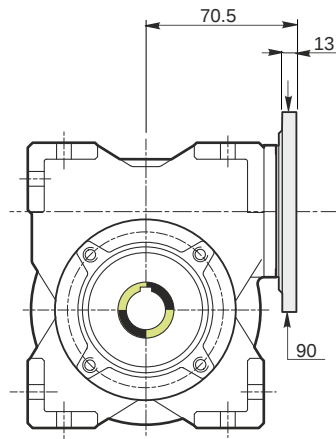

*Hollow output shaft*

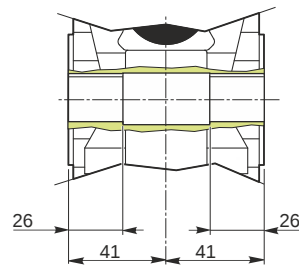
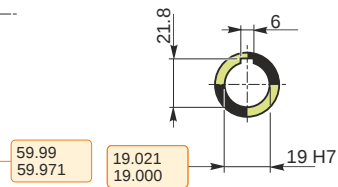

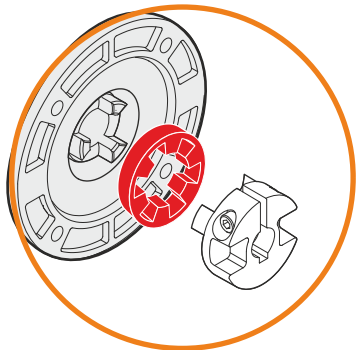
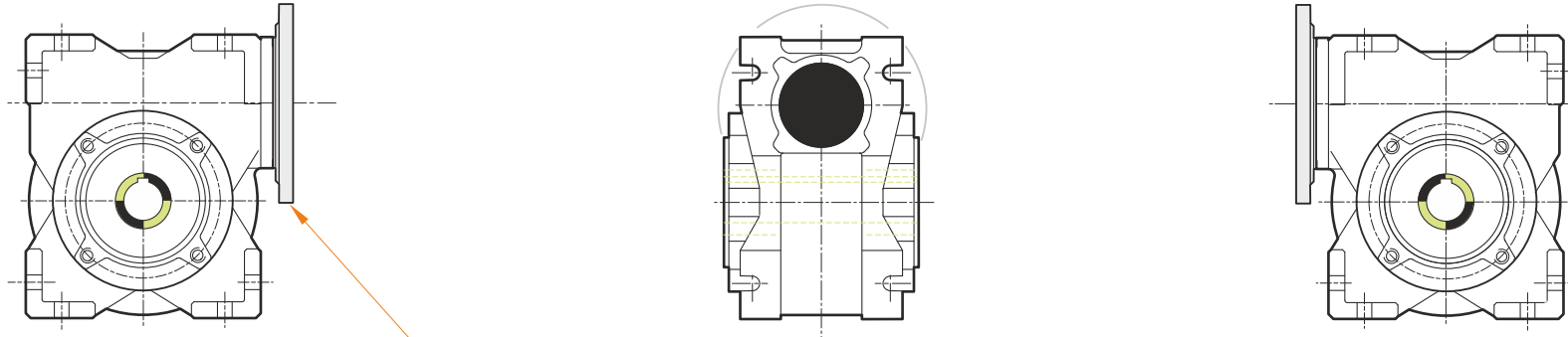

This gear unit is provided with an elastic coupling motor fitting

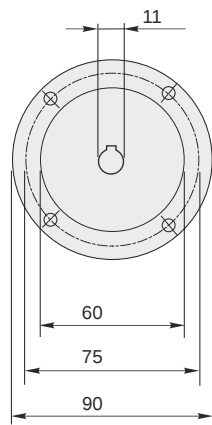

**Mounting positions**

**B3**

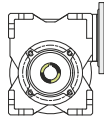

**B6**

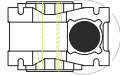

**B7**

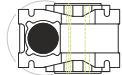

**B8**

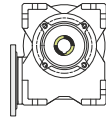

**V5**

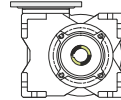

**V6**

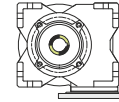

0.08



← Oil quantity [litres]

Lubricant type: Long life synthetic oil ISO VG320

**Direction of rotation**

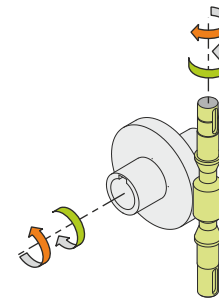
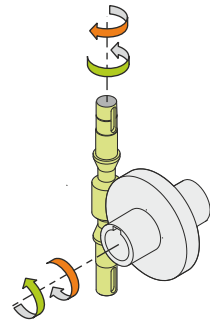
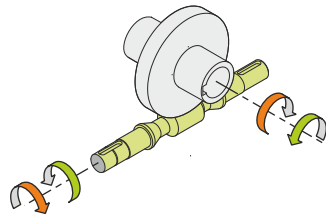

**Weight**

Gear unit [kg] 2.5

**Gearing data**

|                  |        |
|------------------|--------|
| Axial module     | 1.25   |
| Number of starts | 1      |
| Lead angle       | 3° 48' |
| Pressure angle   | 20°    |

**Backdriving**

Static self-locking  
Slow back-driving in case of vibrations  
Low dynamic back-driving