

Input data

System of measurement		Metric
Input type		Coupling for electric motor
Input speed	[rpm]	1400
Output speed	[rpm]	140
Ratio (i=)		10
Frequency	[Hz]	50
Input options		IEC
Requested input power	[kW]	7.5
Service factor		1.2
Rated Power P1	[kW]	8.96

Output data

Gear unit F RT 110 B3 10 132 B14 AC 42

Type		RT - Worm speed reducers
Input type		F
Size		110
Ratio (i=)		10
Input flange		B14
Input speed	[rpm]	1400
Output speed	[rpm]	140
Rated output torque	[Nm]	445.1
Service Factor		1.2
Efficiency		0.87
Inertia moment	[kgm ²]	0.001942

Gear unit configuration

Output shaft		Hollow output shaft
Fixing		Universal
Version		B3

Output radial and axial loads

Ball bearings output radial load	[N]	4150
Taper bearings output radial load	[N]	5400
Ball bearings output axial load	[N]	830
Taper bearings output axial load	[N]	1080

Accessories

Hollow output shaft		AC 42
---------------------	--	-------

Electric motor coupling

Size		132 M4
Poles n.		4
Power	[kW]	7.5

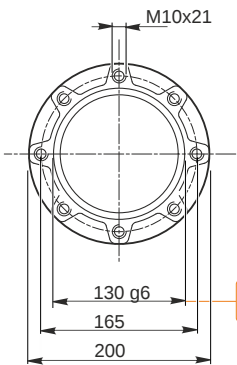
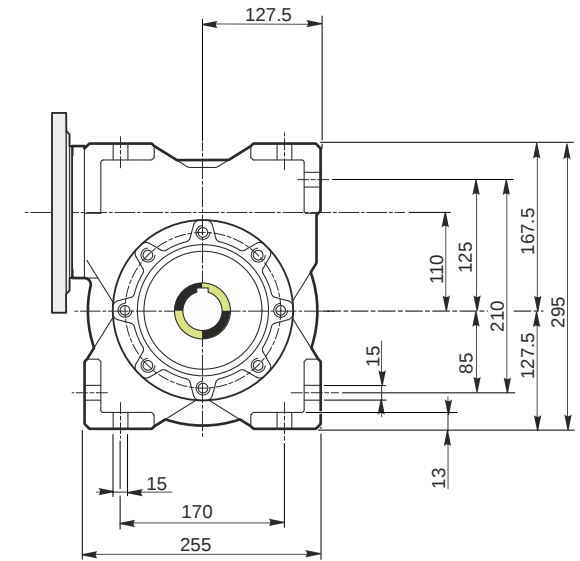
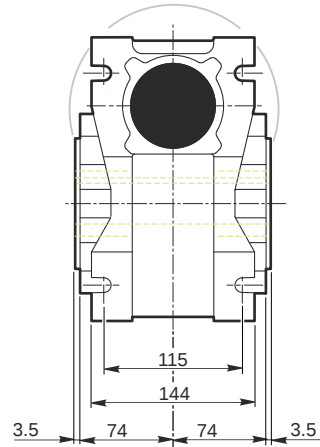
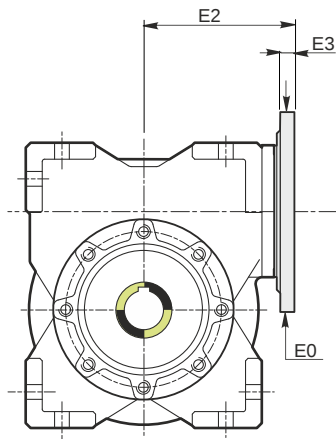

Hollow output shaft

129.986
129.961

42.025
42.000

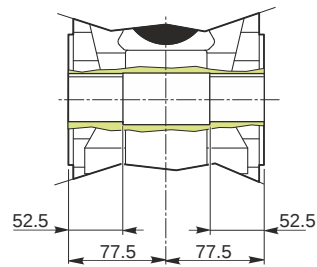
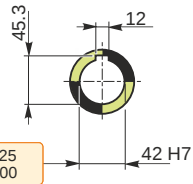

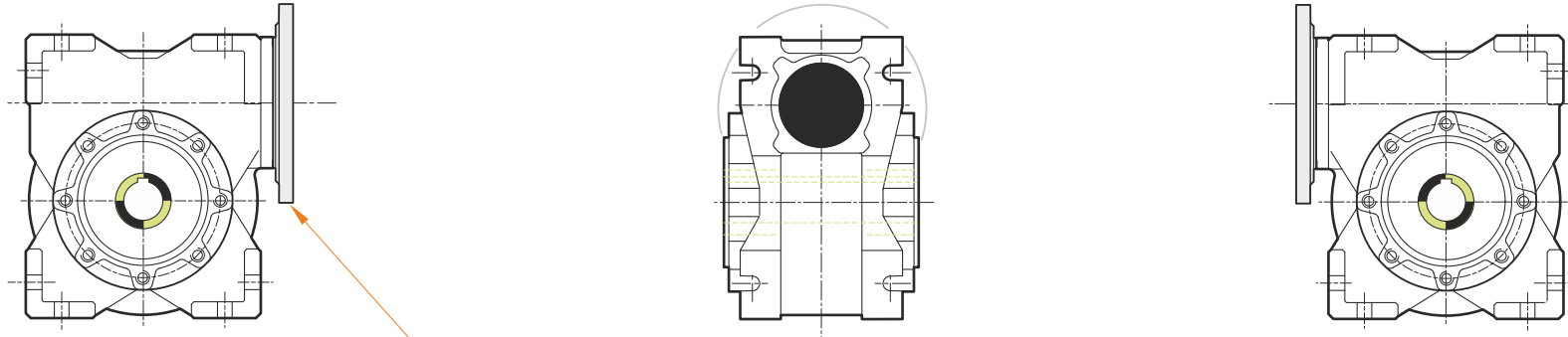

This gear unit is provided with an elastic coupling motor fitting

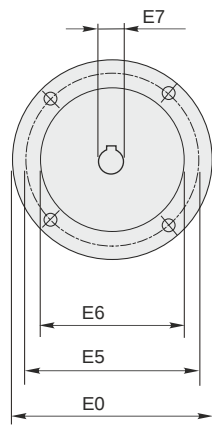

Mounting positions

B3

B6

B7

B8

V5

V6

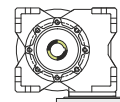
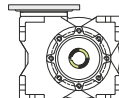
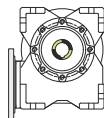
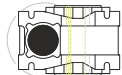
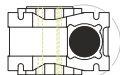
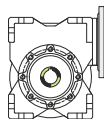

1.5



← Oil quantity [litres]

Lubricant type: Long life synthetic oil ISO VG320

Direction of rotation

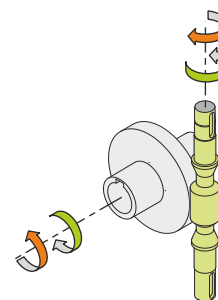
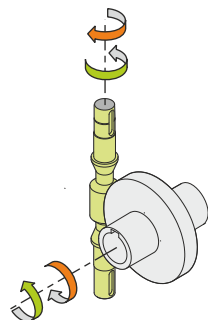
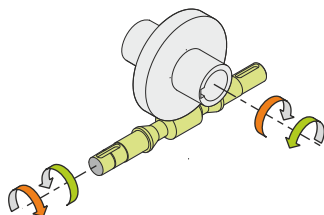
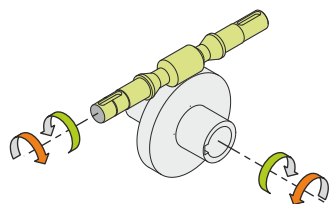

Weight

Gear unit [kg] 39

Gearing data

Axial module	5.8
Number of starts	3
Lead angle	20° 43'
Pressure angle	20°

Backdriving

Static back-driving
Quick back-driving
Dynamic back-driving