

Input data

System of measurement		Metric
Input type		Coupling for electric motor
Input speed	[rpm]	1400
Output speed	[rpm]	50
Ratio (i=)		28
Frequency	[Hz]	50
Input options		IEC
Requested input power	[kW]	3
Service factor		1.5
Rated Power P1	[kW]	4.42

Output data

Gear unit F RT 110 B3 28 100 B14 AC 42

Type		RT - Worm speed reducers
Input type		F
Size		110
Ratio (i=)		28
Input flange		B14
Input speed	[rpm]	1400
Output speed	[rpm]	50
Rated output torque	[Nm]	435.48
Service Factor		1.5
Efficiency		0.76
Inertia moment	[kgm ²]	0.001713

Gear unit configuration

Output shaft		Hollow output shaft
Fixing		Universal
Version		B3

Output radial and axial loads

Ball bearings output radial load	[N]	5900
Taper bearings output radial load	[N]	8000
Ball bearings output axial load	[N]	1180
Taper bearings output axial load	[N]	1600

Accessories

Hollow output shaft		AC 42
---------------------	--	-------

Electric motor coupling

Size		100 B4
Poles n.		4
Power	[kW]	3

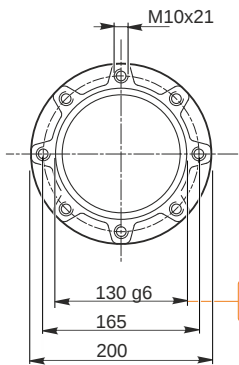
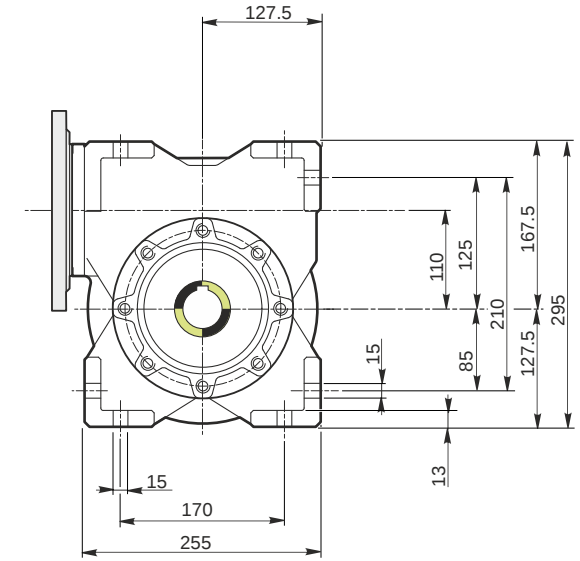
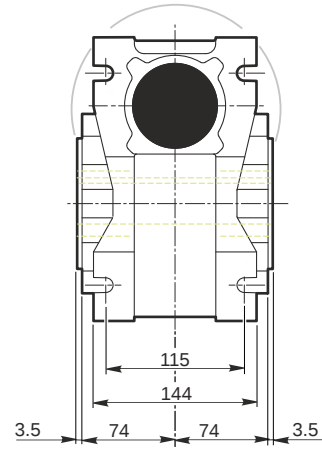
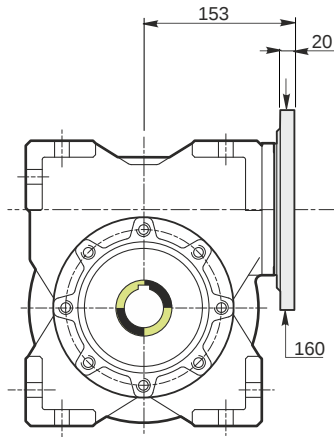

Hollow output shaft

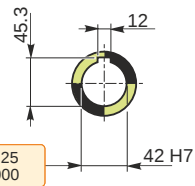

129.986
129.961

42.025
42.000

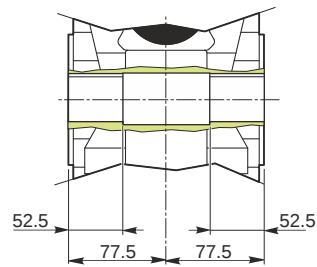

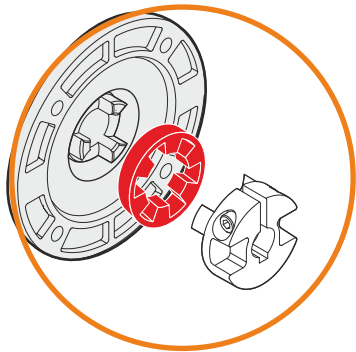
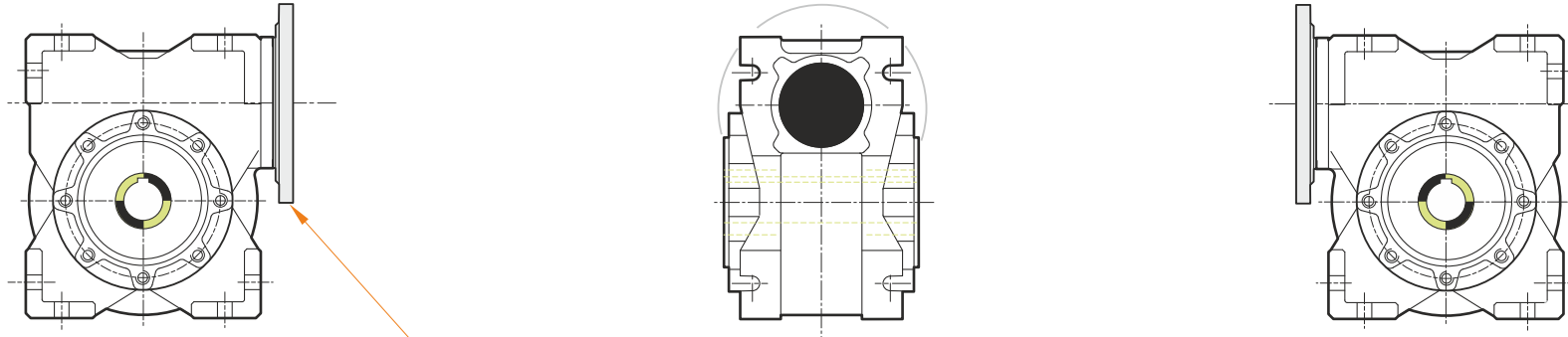

This gear unit is provided with an elastic coupling motor fitting

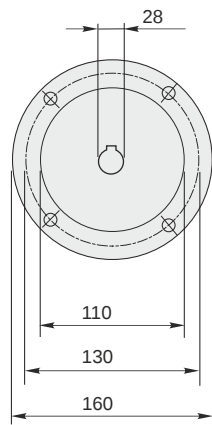

Mounting positions

B3

B6

B7

B8

V5

V6

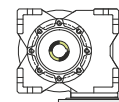
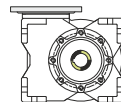
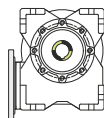
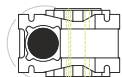
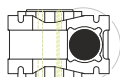
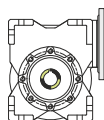

1.5



← Oil quantity [litres]

Lubricant type: Long life synthetic oil ISO VG320

Direction of rotation

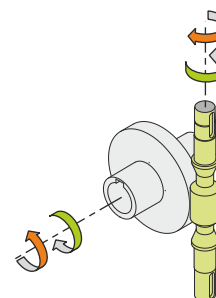
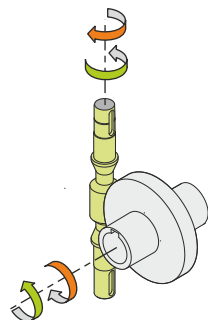
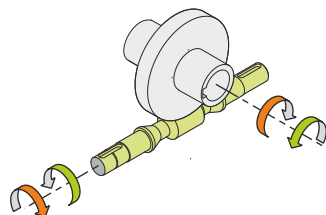
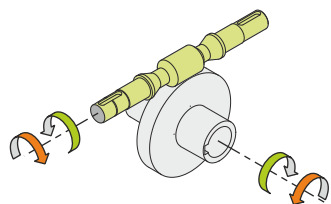

Weight

Gear unit [kg] 39

Gearing data

Axial module	6.1
Number of starts	1
Lead angle	7° 04'
Pressure angle	20°

Backdriving

Static self-locking
Slow back-driving in case of vibrations
Low dynamic back-driving