

### Input data

System of measurement		Metric
Input type		Gear motor
Input speed	[rpm]	1400
Output speed	[rpm]	140
Ratio (i=)		10
Frequency	[Hz]	50
Input options		IEC
Requested input power	[kW]	0.75
Service factor		1.7
Rated Power P1	[kW]	1.31

### Output data

**Gear unit** **M RT 50 B3 10 80 B14 AC 24 MT 0.75 kW 80 B4 B14 X3**

Type		RT - Worm speed reducers
Input type		M
Size		50
Ratio (i=)		10
Input flange		B14
Input speed	[rpm]	1400
Output speed	[rpm]	140
Rated output torque	[Nm]	42.98
Service Factor		1.7
Efficiency		0.84
Inertia moment	[kgm <sup>2</sup> ]	0.000054

#### Gear unit configuration

Output shaft		Hollow output shaft
Fixing		Universal
Version		B3

#### Output radial and axial loads

Ball bearings output radial load	[N]	1450
Taper bearings output radial load	[N]	2000
Ball bearings output axial load	[N]	290
Taper bearings output axial load	[N]	400

#### Accessories

Hollow output shaft		AC 24
---------------------	--	-------

#### Electric motor

Size		80 B4
Poles		4
Power	[kW]	0.75

#### Electric motor configuration

Motor flange		B14
Terminal box position		X3

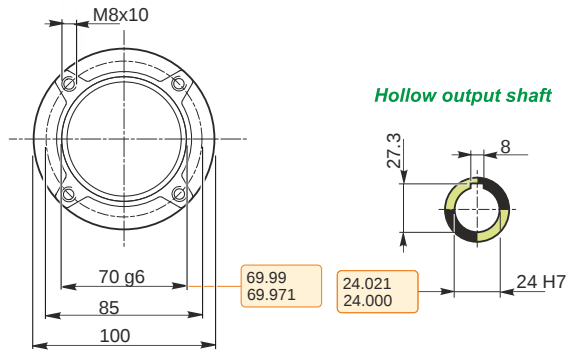
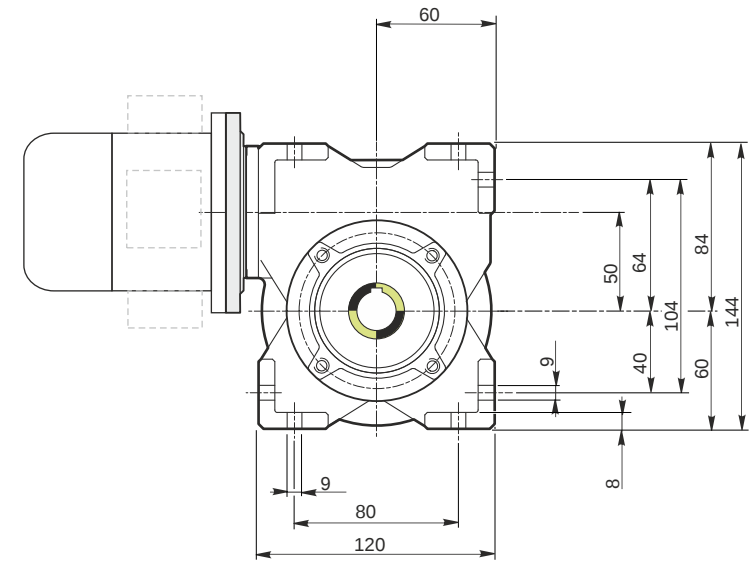
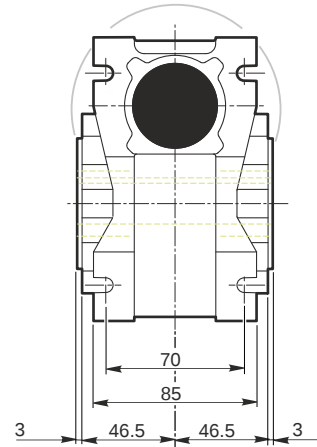
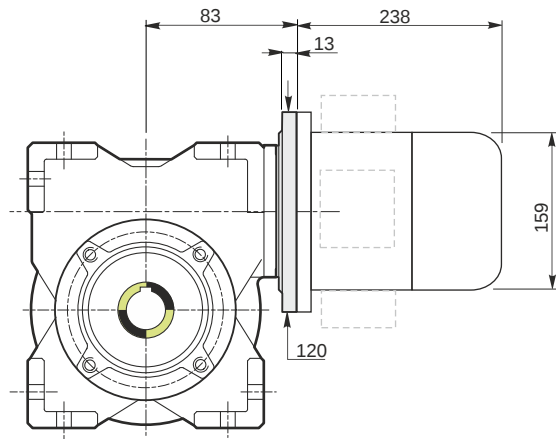

*Hollow output shaft*

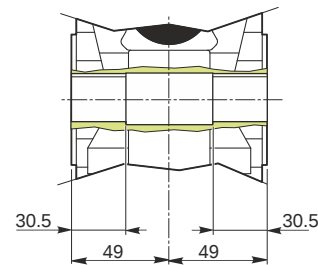

**Mounting positions**

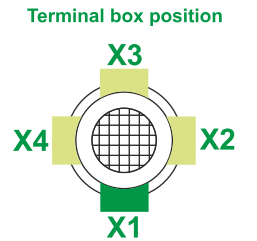
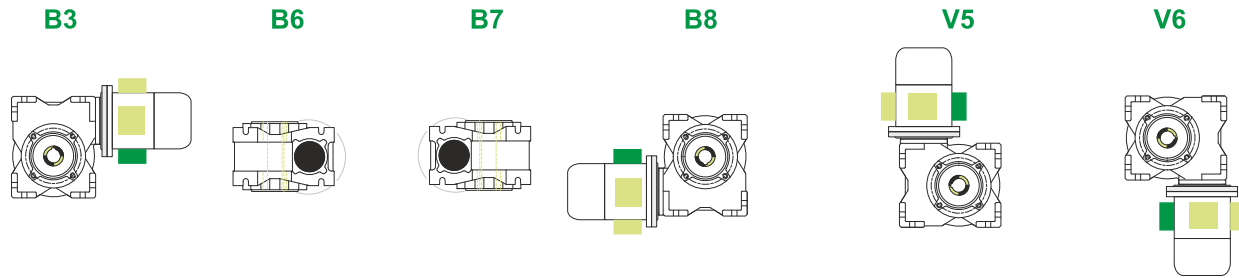

0.13



← Oil quantity [litres]

Lubricant type: Long life synthetic oil ISO VG320

**Direction of rotation**

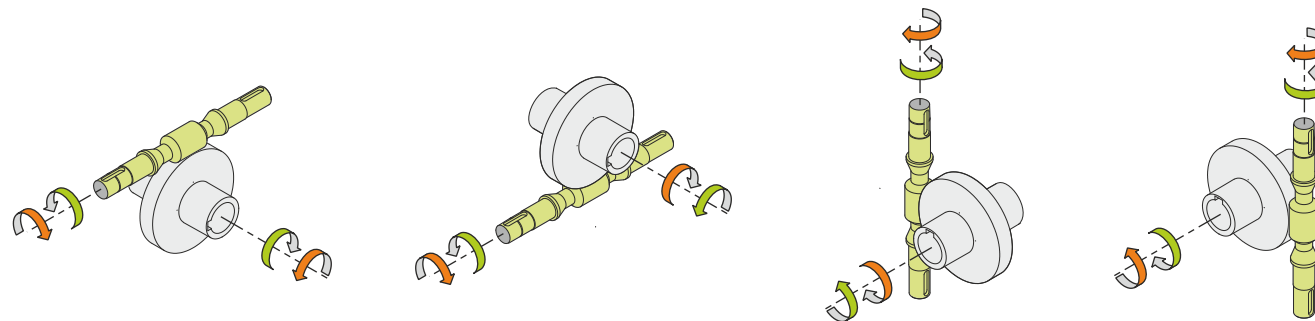

**Weight**

Gear unit [kg]	3.8
Electric motor [kg]	9.8

**Gearing data**

Axial module	2.5
Number of starts	3
Lead angle	16° 41'
Pressure angle	20°

**Backdriving**

- Static back-driving
- Quick back-driving
- Dynamic back-driving

**M RT 50 B3 10 80 B14 AC 24 MT 0.75 kW 80 B4 B14 X3**