

Input data

System of measurement		Metric
Input type		Gear motor
Input speed	[rpm]	1400
Output speed	[rpm]	17.5
Ratio (i=)		80
Frequency	[Hz]	50
Input options		IEC
Requested input power	[kW]	0.55
Service factor		0.9
Rated Power P1	[kW]	0.5

Output data

Gear unit **M RT 70 B3 80 80 B14 AC 28 MT 0.55 kW 80 A4 B14 X3**

Type		RT - Worm speed reducers
Input type		M
Size		70
Ratio (i=)		80
Input flange		B14
Input speed	[rpm]	1400
Output speed	[rpm]	17.5
Rated output torque	[Nm]	168.08
Service Factor		0.9
Efficiency		0.56
Inertia moment	[kgm ²]	0.000244

Gear unit configuration

Output shaft		Hollow output shaft
Fixing		Universal
Version		B3

Output radial and axial loads

Ball bearings output radial load	[N]	6300
Taper bearings output radial load	[N]	7900
Ball bearings output axial load	[N]	1260
Taper bearings output axial load	[N]	1580

Accessories

Hollow output shaft		AC 28
---------------------	--	-------

Electric motor

Size		80 A4
Poles		4
Power	[kW]	0.55

Electric motor configuration

Motor flange		B14
Terminal box position		X3

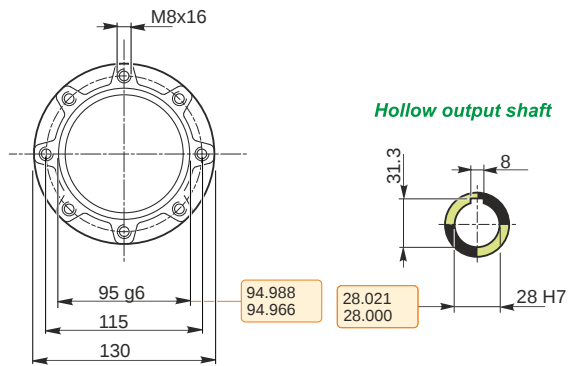
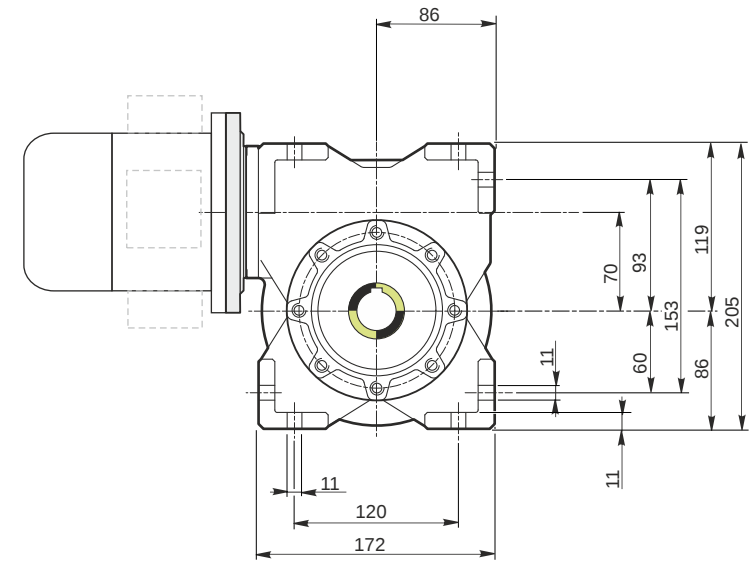
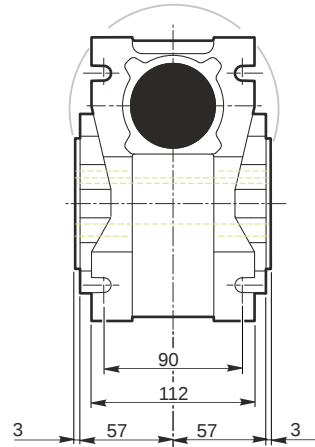
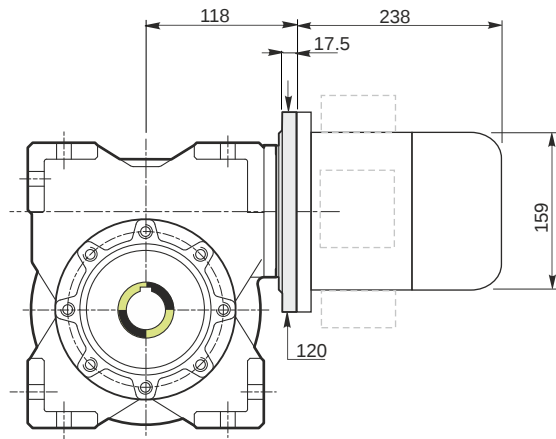

Hollow output shaft

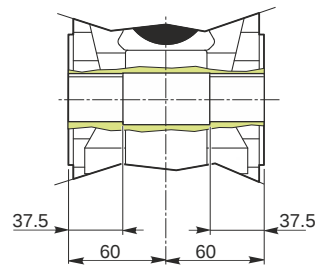

Mounting positions

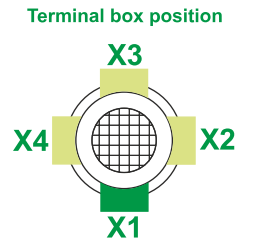
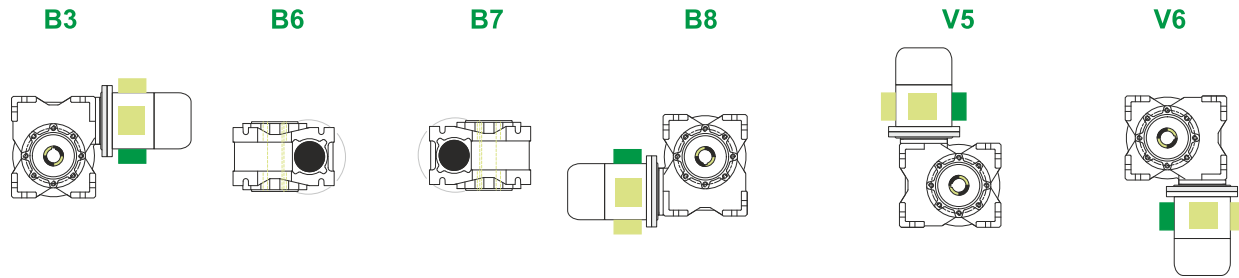

0.35



← Oil quantity [litres]

Lubricant type: Long life synthetic oil ISO VG320

Direction of rotation

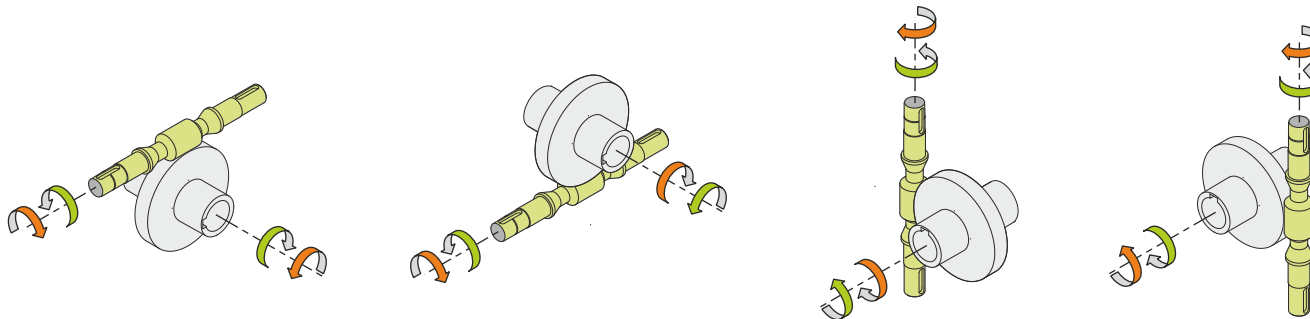

Weight

Gear unit [kg]	9
Electric motor [kg]	9.8

Gearing data

Axial module	1.4
Number of starts	1
Lead angle	2° 51'
Pressure angle	20°

Backdriving

Static self-locking
No back-driving
Low dynamic back-driving