

Input data

System of measurement		Metric
Input type		Gear motor
Input speed	[rpm]	1400
Output speed	[rpm]	17.5
Ratio (i=)		80
Frequency	[Hz]	50
Input options		IEC
Requested input power	[kW]	1.5
Service factor		1
Rated Power P1	[kW]	1.46

Output data

Gear unit **M RT 110 B3 80 90 B5 AC 42 MT 1.5 kW 90 L4 B5 X3**

Type		RT - Worm speed reducers
Input type		M
Size		110
Ratio (i=)		80
Input flange		B5
Input speed	[rpm]	1400
Output speed	[rpm]	17.5
Rated output torque	[Nm]	540.26
Service Factor		1
Efficiency		0.66
Inertia moment	[kgm ²]	0.001684

Gear unit configuration

Output shaft		Hollow output shaft
Fixing		Universal
Version		B3

Output radial and axial loads

Ball bearings output radial load	[N]	8800
Taper bearings output radial load	[N]	11100
Ball bearings output axial load	[N]	1760
Taper bearings output axial load	[N]	2220

Accessories

Hollow output shaft		AC 42
---------------------	--	-------

Electric motor

Size		90 L4
Poles		4
Power	[kW]	1.5

Electric motor configuration

Motor flange		B5
Terminal box position		X3

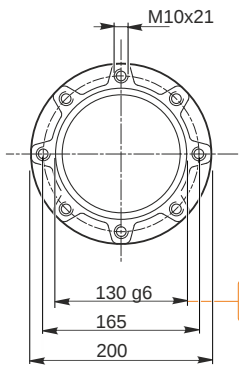
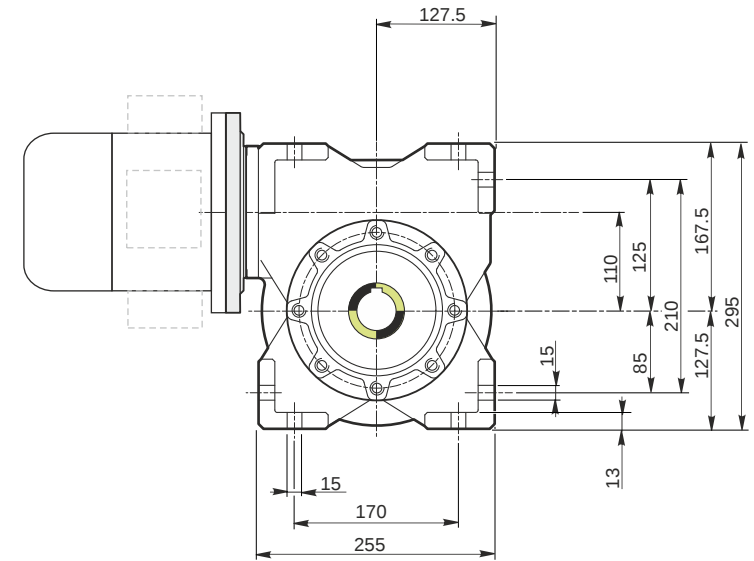
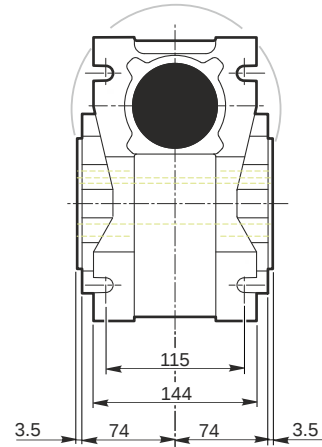
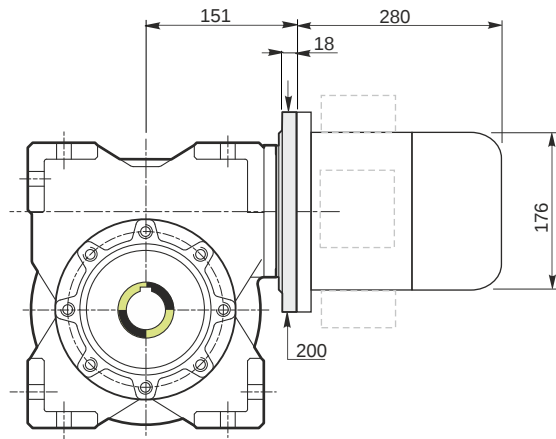

Hollow output shaft

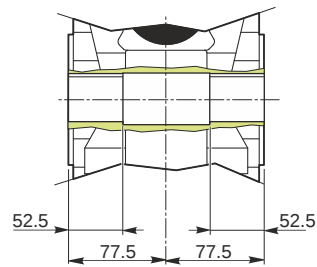
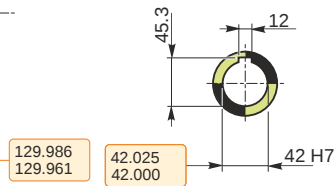

Mounting positions

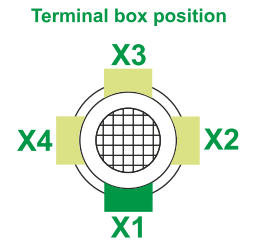
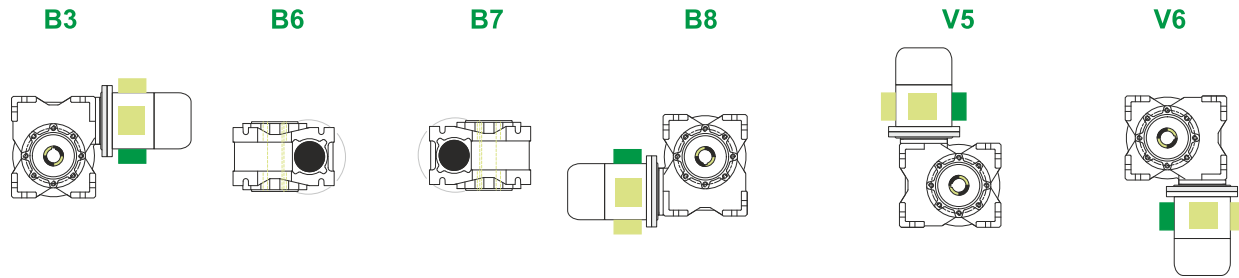

1.5



← Oil quantity [litres]

Lubricant type: Long life synthetic oil ISO VG320

Direction of rotation

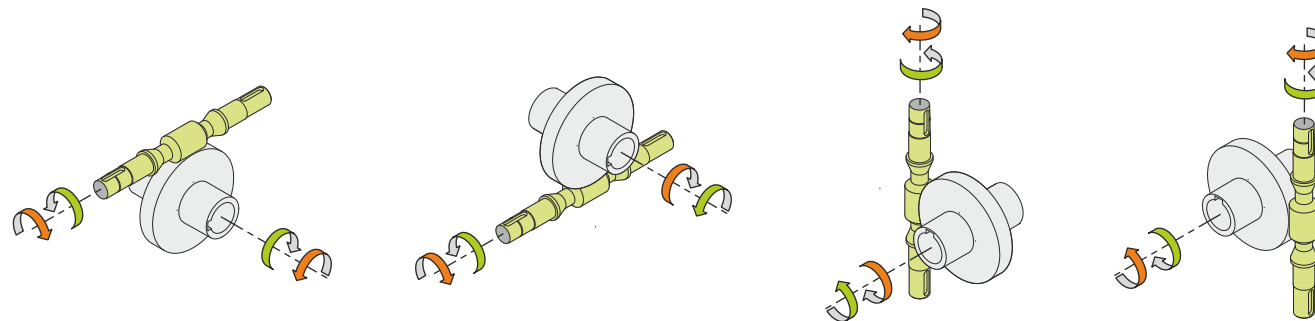

Weight

Gear unit [kg]	39
Electric motor [kg]	13.5

Gearing data

Axial module	2.3
Number of starts	1
Lead angle	3° 39'
Pressure angle	20°

Backdriving

Static self-locking
Slow back-driving in case of vibrations
Low dynamic back-driving