

Input data

System of measurement		Metric
Input type		Coupling for electric motor
Input speed	[rpm]	1400
Output speed	[rpm]	93.33
Ratio (i=)		15
Frequency	[Hz]	50
Input options		IEC
Requested input power	[kW]	0.18
Service factor		1.3
Rated Power P1	[kW]	0.23

Output data

Gear unit F RS 28 PC 15 63 B14 AC 14 B3

Type		RS - Worm speed reducers
Input type		F (Elastic coupling)
Size		28
Ratio (i=)		15
Input flange		B14
Mounting position		B3
Input speed	[rpm]	1400
Output speed	[rpm]	93.33
Rated output torque	[Nm]	14.18
Service Factor		1.3
Efficiency		0.77
Inertia moment	[kgm ²]	0.000005

Gear unit configuration

Output shaft		Hollow output shaft
Fixing		Shaft mounting
Version		PC

Output radial and axial loads

Ball bearings output radial load	[N]	550
Taper bearings output radial load	[N]	820
Ball bearings output axial load	[N]	110
Taper bearings output axial load	[N]	164

Accessories

Hollow output shaft		AC 14
---------------------	--	-------

Electric motor coupling

Size		63 B4
Poles n.		4
Power	[kW]	0.18

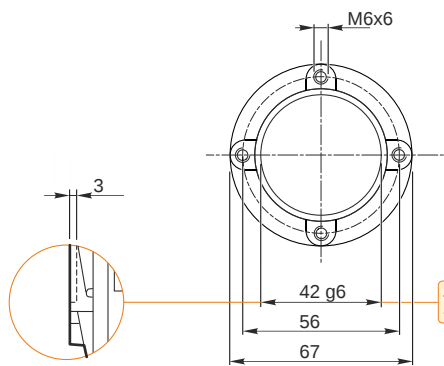
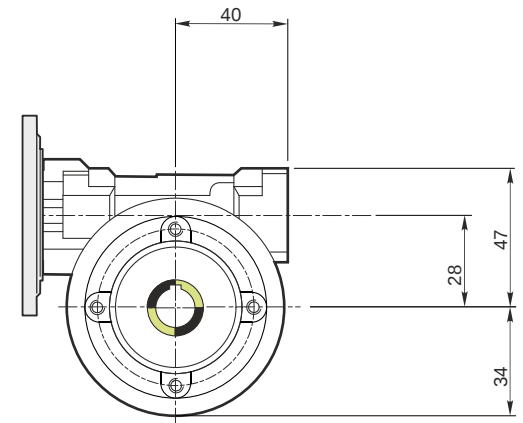
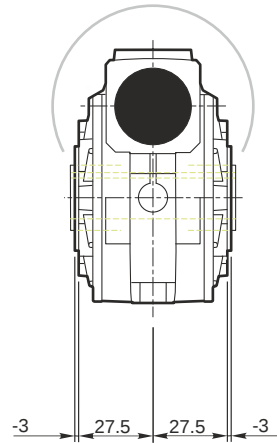
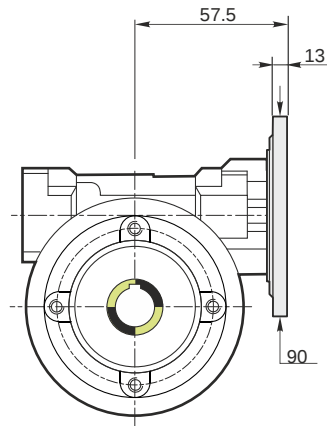

Hollow output shaft

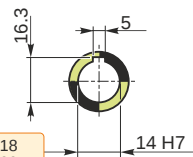

41.991
41.975

14.018
14.000

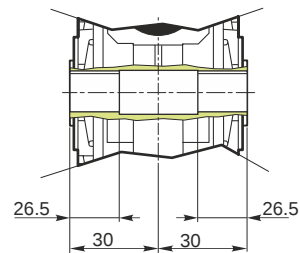

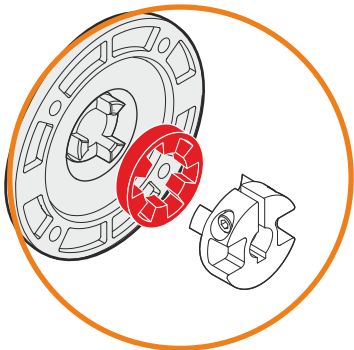
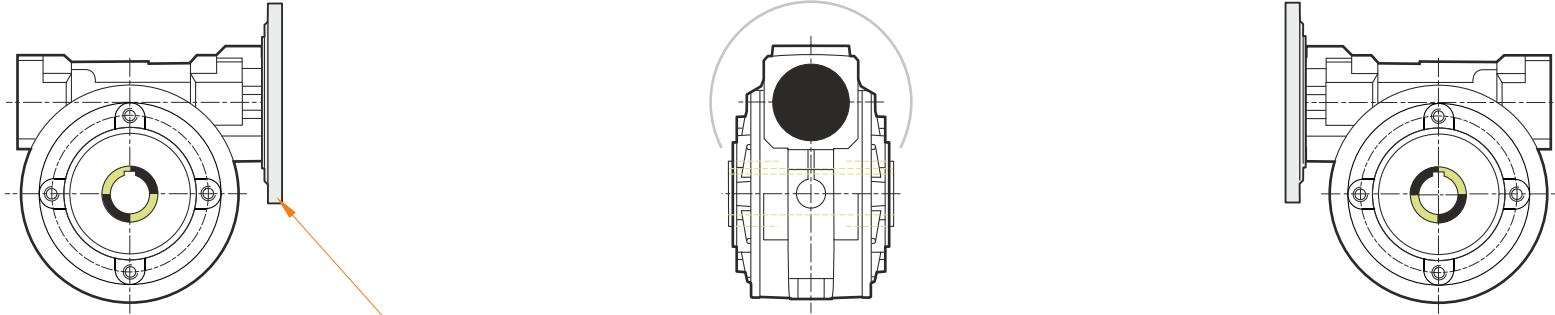

This gear unit is provided with an elastic coupling motor fitting

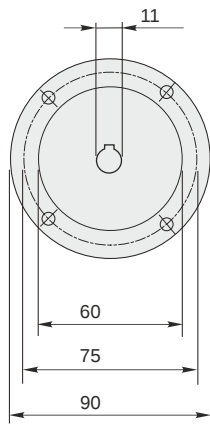

Mounting positions

B3

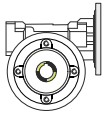

B6

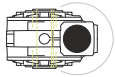

B7

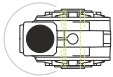

B8

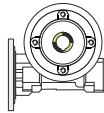

V5

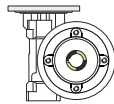

V6

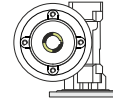

0.03



← Oil quantity [litres]

Lubricant type: Long life synthetic oil ISO VG320

Direction of rotation

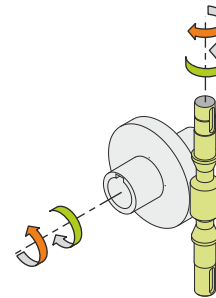
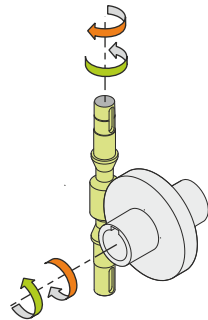
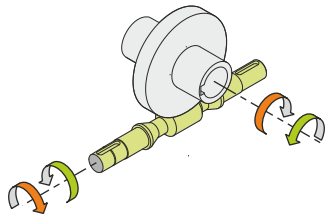
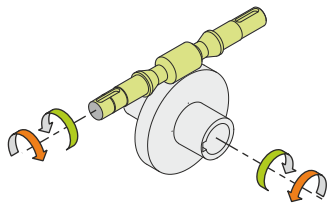

Weight

Gear unit [kg] 1.1

Gearing data

Axial module	1.4
Number of starts	2
Lead angle	11° 18'
Pressure angle	20°

Backdriving

Variable static self-locking
Quick back-driving in case of vibrations
Dynamic back-driving