

Input data

System of measurement		Metric
Input type		Coupling for electric motor
Input speed	[rpm]	1400
Output speed	[rpm]	93.33
Ratio (i=)		15
Frequency	[Hz]	50
Input options		IEC
Requested input power	[kW]	7.5
Service factor		1.5
Rated Power P1	[kW]	11.04

Output data

Gear unit F RS 130 PC 15 132 B14 AC 48 B3

Type		RS - Worm speed reducers
Input type		F
Size		130
Ratio (i=)		15
Input flange		B14
Mounting position		B3
Input speed	[rpm]	1400
Output speed	[rpm]	93.33
Rated output torque	[Nm]	652.3
Service Factor		1.5
Efficiency		0.85
Inertia moment	[kgm ²]	0.002928

Gear unit configuration

Output shaft		Hollow output shaft
Fixing		Shaft mounting
Version		PC

Output radial and axial loads

Ball bearings output radial load	[N]	6150
Taper bearings output radial load	[N]	8600
Ball bearings output axial load	[N]	1230
Taper bearings output axial load	[N]	1720

Accessories

Hollow output shaft		AC 48
---------------------	--	-------

Electric motor coupling

Size		132 M4
Poles n.		4
Power	[kW]	7.5

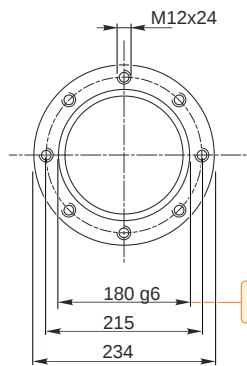
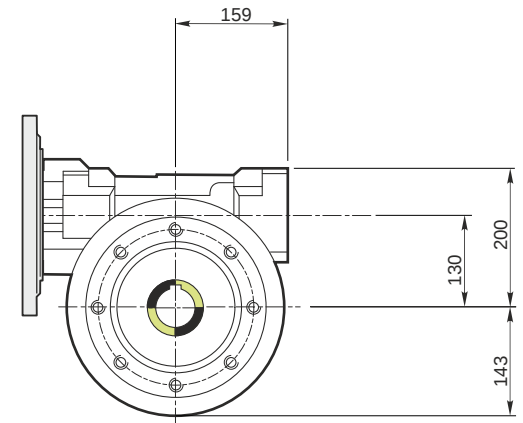
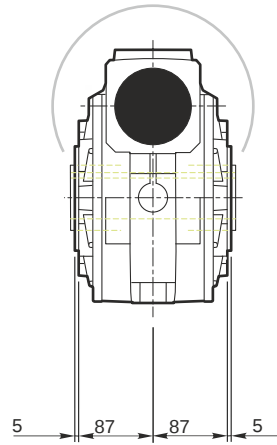
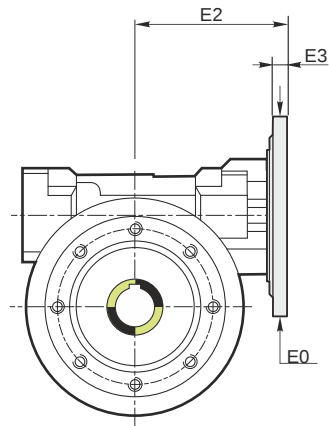

Hollow output shaft

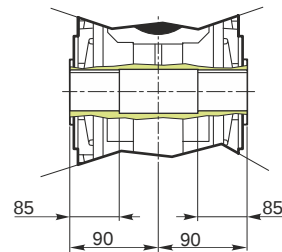
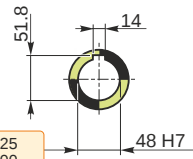

179.986
179.961

48.025
48.000

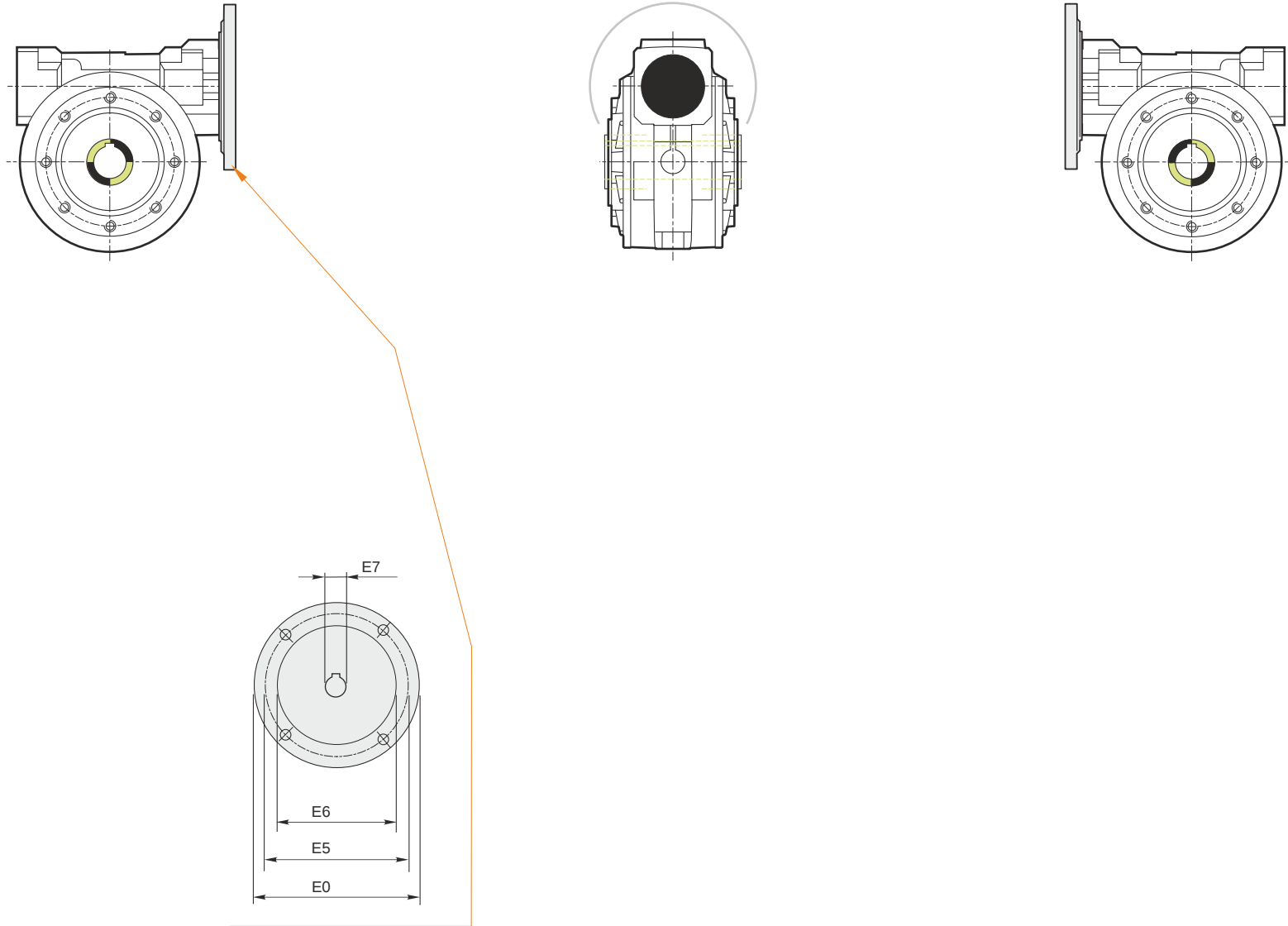

Mounting positions

B3

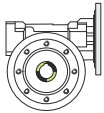

B6



B7



B8

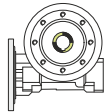

V5

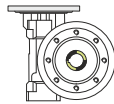

V6

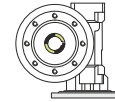

2.75



← Oil quantity [litres]

Lubricant type: Long life synthetic oil ISO VG320

Direction of rotation

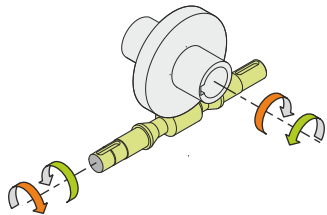

Weight

Gear unit [kg] 50

Gearing data

Axial module	6.85
Number of starts	2
Lead angle	14° 06'
Pressure angle	20°

Backdriving

Static back-driving
Quick back-driving
Dynamic back-driving