

### Input data

System of measurement		Metric
Input type		Coupling for electric motor
Input speed	[rpm]	1400
Output speed	[rpm]	17.5
Ratio (i=)		80
Frequency	[Hz]	50
Input options		IEC
Requested input power	[kW]	3
Service factor		1.1
Rated Power P1	[kW]	3.3

### Output data

#### **Gear unit** F RS 150 PC 80 100 B14 AC 55 B3

Type		RS - Worm speed reducers
Input type		F (Elastic coupling)
Size		150
Ratio (i=)		80
Input flange		B14
Mounting position		B3
Input speed	[rpm]	1400
Output speed	[rpm]	17.5
Rated output torque	[Nm]	1064.14
Service Factor		1.1
Efficiency		0.65
Inertia moment	[kgm <sup>2</sup> ]	0.005813

#### **Gear unit configuration**

Output shaft		Hollow output shaft
Fixing		Shaft mounting
Version		PC

#### **Output radial and axial loads**

Ball bearings output radial load	[N]	14000
Taper bearings output radial load	[N]	19500
Ball bearings output axial load	[N]	2800
Taper bearings output axial load	[N]	3900

#### **Accessories**

Hollow output shaft		AC 55
---------------------	--	-------

#### **Electric motor coupling**

Size		100 B4
Poles n.		4
Power	[kW]	3

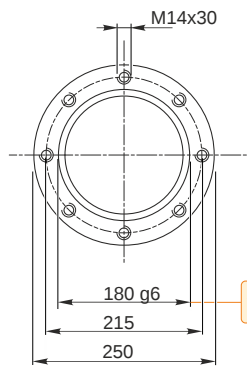
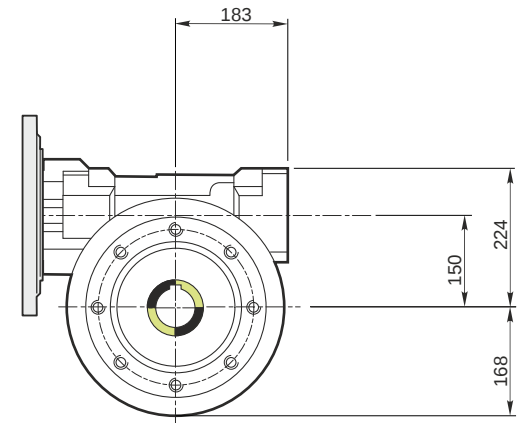
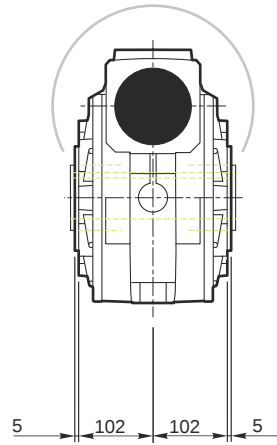
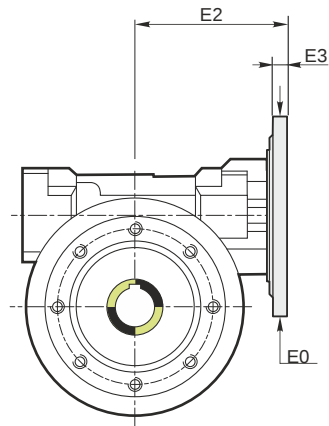

Hollow output shaft

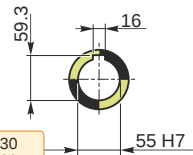

179.986  
179.961

55.030  
55.000

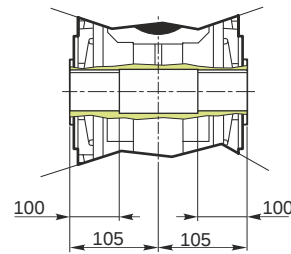

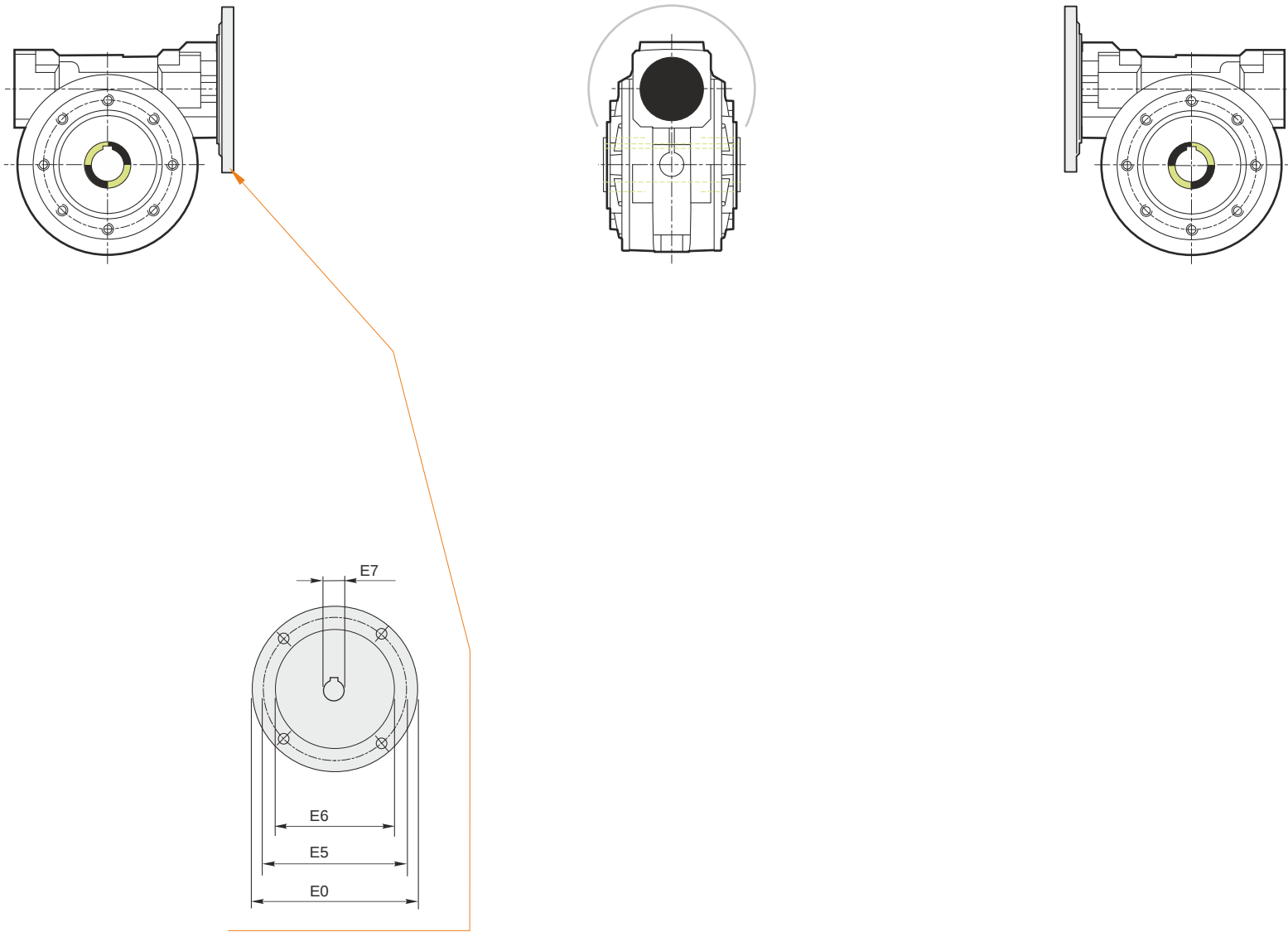

**Mounting positions**

**B3**

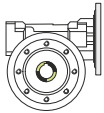

**B6**

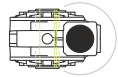

**B7**

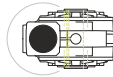

**B8**

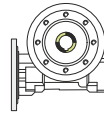

**V5**

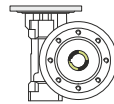

**V6**

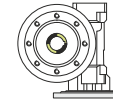

4.4



← Oil quantity [litres]

Lubricant type: Long life synthetic oil ISO VG320

**Direction of rotation**

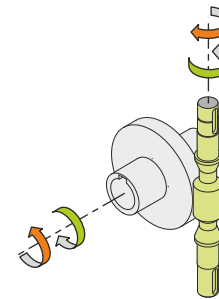
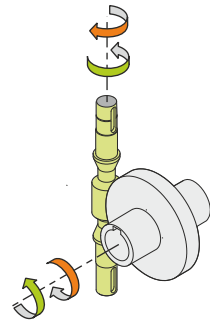
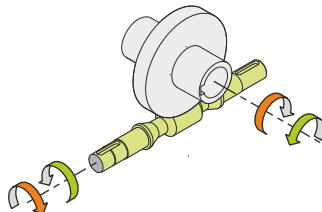
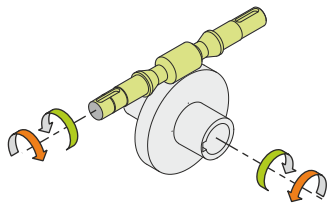

**Weight**

Gear unit [kg] 80

**Gearing data**

Axial module	3.15
Number of starts	1
Lead angle	3° 45'
Pressure angle	20°

**Backdriving**

Static self-locking  
Slow back-driving in case of vibrations  
Low dynamic back-driving