

### Input data

System of measurement		Metric
Input type		Gear motor
Input speed	[rpm]	1400
Output speed	[rpm]	200
Ratio (i=)		7
Frequency	[Hz]	50
Input options		IEC
Requested input power	[kW]	0.18
Service factor		2.5
Rated Power P1	[kW]	0.45

### Output data

**Gear unit** **M RS 28 PC 7 63 B14 AC 14 MT 0.18 kW 63 B4 B14 X3 B3**

Type		RS - Worm speed reducers
Input type		M
Size		28
Ratio (i=)		7
Input flange		B14
Mounting position		B3
Input speed	[rpm]	1400
Output speed	[rpm]	200
Rated output torque	[Nm]	7.22
Service Factor		2.5
Efficiency		0.84
Inertia moment	[kgm <sup>2</sup> ]	0.000006

#### Gear unit configuration

Output shaft		Hollow output shaft
Fixing		Shaft mounting
Version		PC

#### Output radial and axial loads

Ball bearings output radial load	[N]	450
Taper bearings output radial load	[N]	650
Ball bearings output axial load	[N]	90
Taper bearings output axial load	[N]	130

#### Accessories

Hollow output shaft		AC 14
---------------------	--	-------

#### Electric motor

Size		63 B4
Poles		4
Power	[kW]	0.18

#### Electric motor configuration

Motor flange		B14
Terminal box position		X3

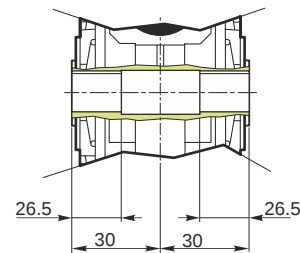
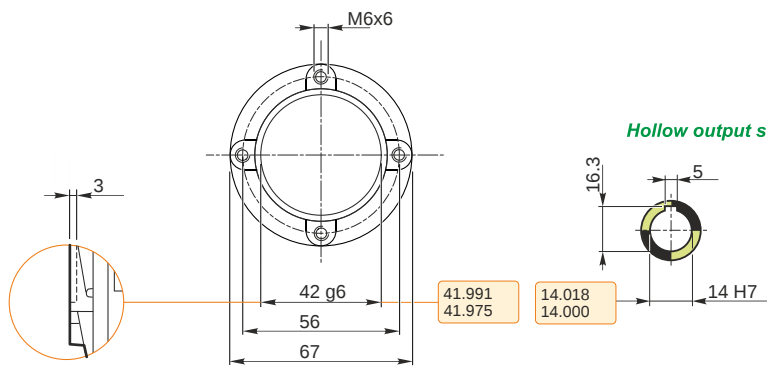
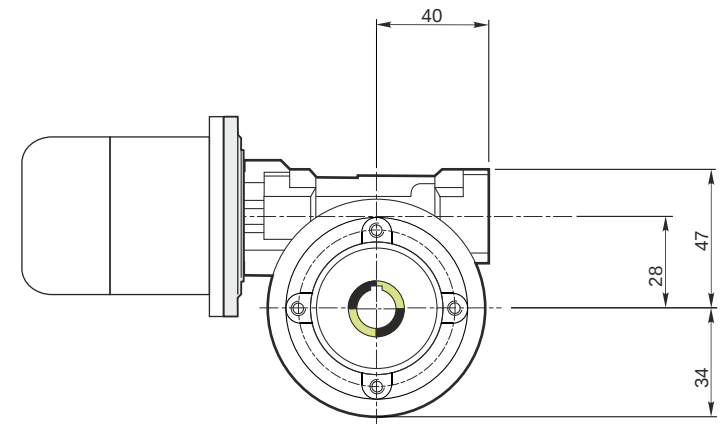
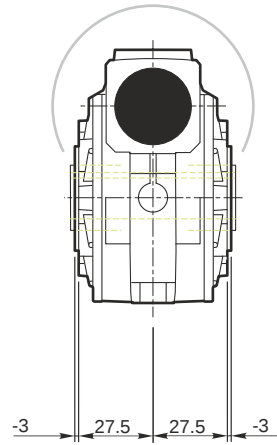
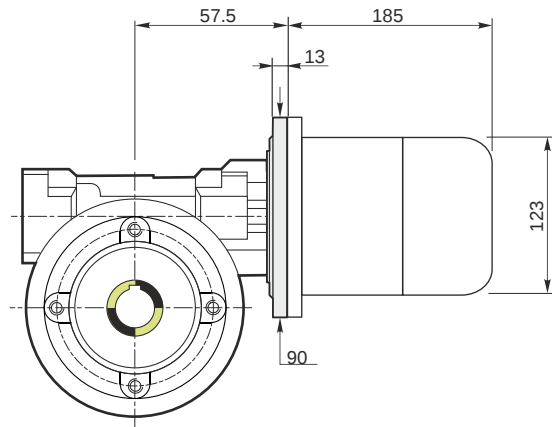

**M RS 28 PC 7 63 B14 AC 14 MT 0.18 kW 63 B4 B14 X3 B3**

**Mounting positions**

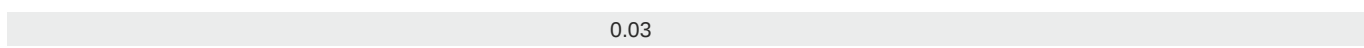
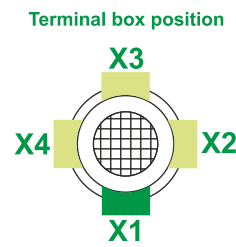
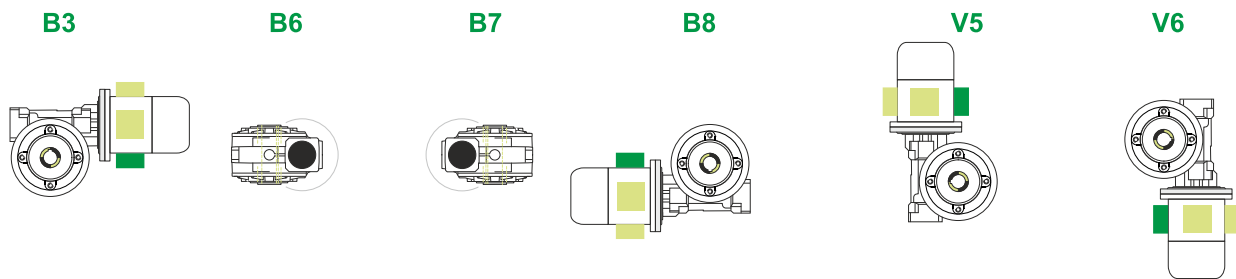

Lubricant type: Long life synthetic oil ISO VG320

**Direction of rotation**

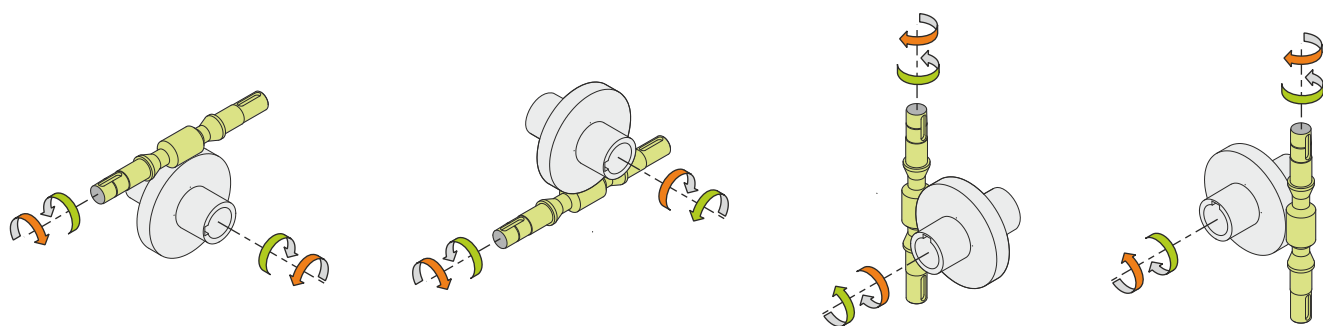

**Weight**

Gear unit [kg]	1.1
Electric motor [kg]	4.3

**Gearing data**

Axial module	1.5
Number of starts	4
Lead angle	23° 11'
Pressure angle	20°

**Backdriving**

- Static back-driving
- Quick back-driving
- Dynamic back-driving

**M RS 28 PC 7 63 B14 AC 14 MT 0.18 kW 63 B4 B14 X3 B3**