

Input data

System of measurement		Metric
Input type		Gear motor
Input speed	[rpm]	1400
Output speed	[rpm]	93.33
Ratio (i=)		15
Frequency	[Hz]	50
Input options		IEC
Requested input power	[kW]	0.18
Service factor		1.3
Rated Power P1	[kW]	0.23

Output data

Gear unit **M RS 28 PC 15 63 B14 AC 14 MT 0.18 kW 63 B4 B14 X3 B3**

Type		RS - Worm speed reducers
Input type		M
Size		28
Ratio (i=)		15
Input flange		B14
Mounting position		B3
Input speed	[rpm]	1400
Output speed	[rpm]	93.33
Rated output torque	[Nm]	14.18
Service Factor		1.3
Efficiency		0.77
Inertia moment	[kgm ²]	0.000005

Gear unit configuration

Output shaft		Hollow output shaft
Fixing		Shaft mounting
Version		PC

Output radial and axial loads

Ball bearings output radial load	[N]	550
Taper bearings output radial load	[N]	820
Ball bearings output axial load	[N]	110
Taper bearings output axial load	[N]	164

Accessories

Hollow output shaft		AC 14
---------------------	--	-------

Electric motor

Size		63 B4
Poles		4
Power	[kW]	0.18

Electric motor configuration

Motor flange		B14
Terminal box position		X3

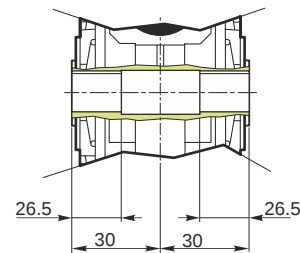
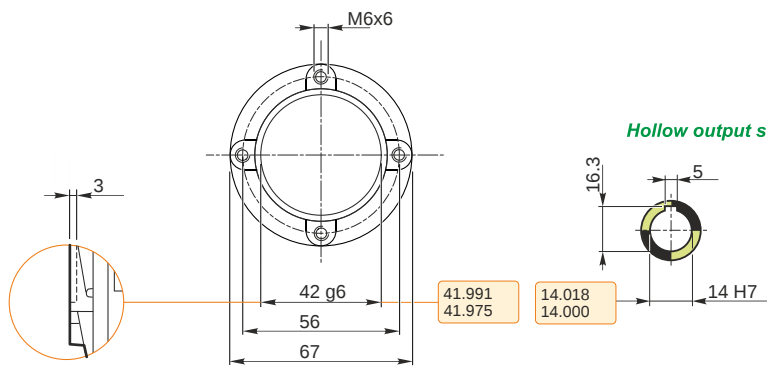
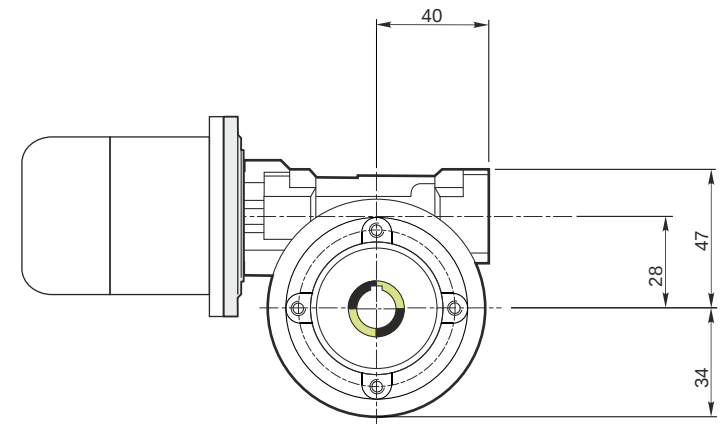
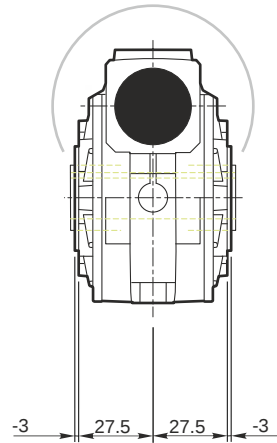
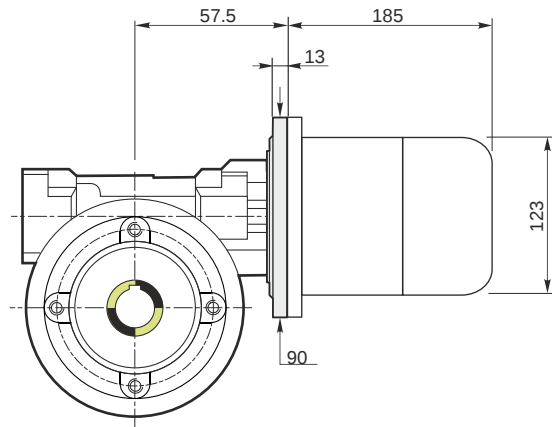

M RS 28 PC 15 63 B14 AC 14 MT 0.18 kW 63 B4 B14 X3 B3

Mounting positions

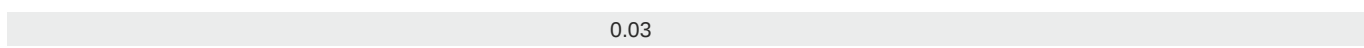
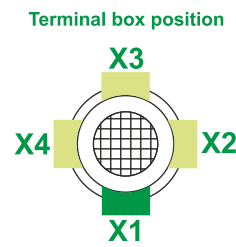
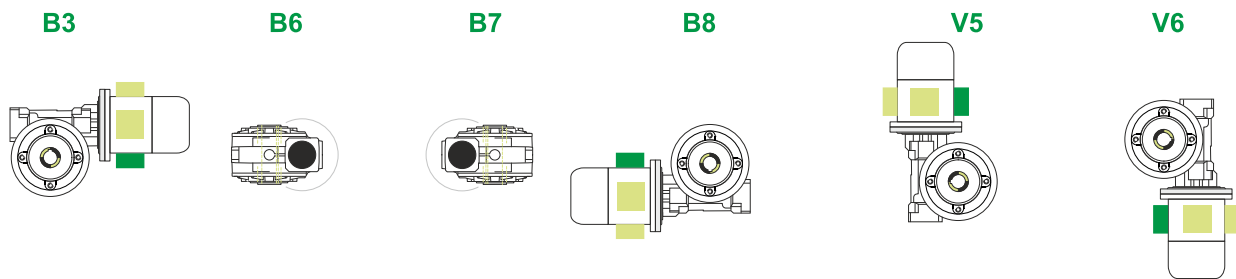

Lubricant type: Long life synthetic oil ISO VG320

Direction of rotation

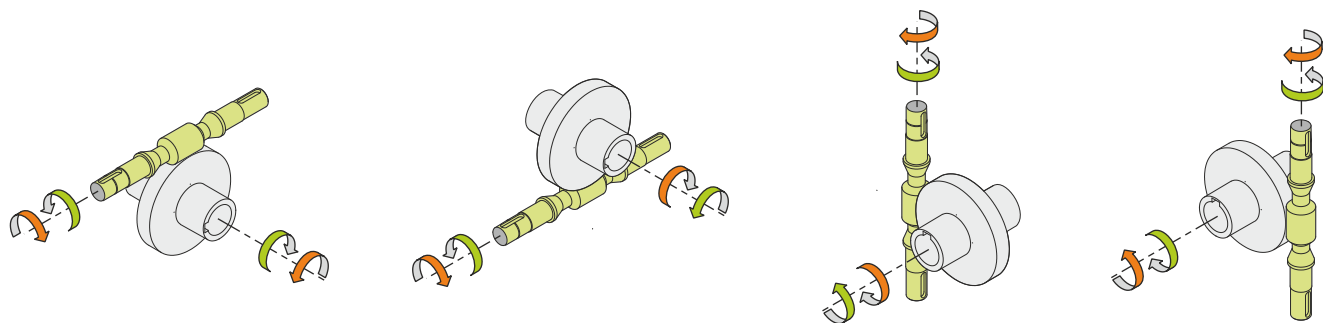

Weight

Gear unit [kg]	1.1
Electric motor [kg]	4.3

Gearing data

Axial module	1.4
Number of starts	2
Lead angle	11° 18'
Pressure angle	20°

Backdriving

Variable static self-locking
Quick back-driving in case of vibrations
Dynamic back-driving

M RS 28 PC 15 63 B14 AC 14 MT 0.18 kW 63 B4 B14 X3 B3