

Input data

System of measurement		Metric
Input type		Gear motor
Input speed	[rpm]	1400
Output speed	[rpm]	35
Ratio (i=)		40
Frequency	[Hz]	50
Input options		IEC
Requested input power	[kW]	0.09
Service factor		1.1
Rated Power P1	[kW]	0.1

Output data

Gear unit **M RS 28 PC 40 56 B14 AC 14 MT 0.09 kW 56 B4 B14 X3 B3**

Type		RS - Worm speed reducers
Input type		M
Size		28
Ratio (i=)		40
Input flange		B14
Mounting position		B3
Input speed	[rpm]	1400
Output speed	[rpm]	35
Rated output torque	[Nm]	15.23
Service Factor		1.1
Efficiency		0.62
Inertia moment	[kgm ²]	0.000005

Gear unit configuration

Output shaft		Hollow output shaft
Fixing		Shaft mounting
Version		PC

Output radial and axial loads

Ball bearings output radial load	[N]	700
Taper bearings output radial load	[N]	1050
Ball bearings output axial load	[N]	140
Taper bearings output axial load	[N]	210

Accessories

Hollow output shaft		AC 14
---------------------	--	-------

Electric motor

Size		56 B4
Poles		4
Power	[kW]	0.09

Electric motor configuration

Motor flange		B14
Terminal box position		X3

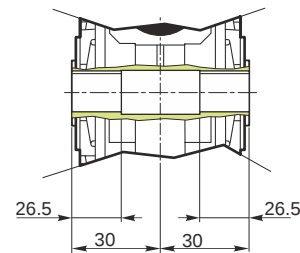
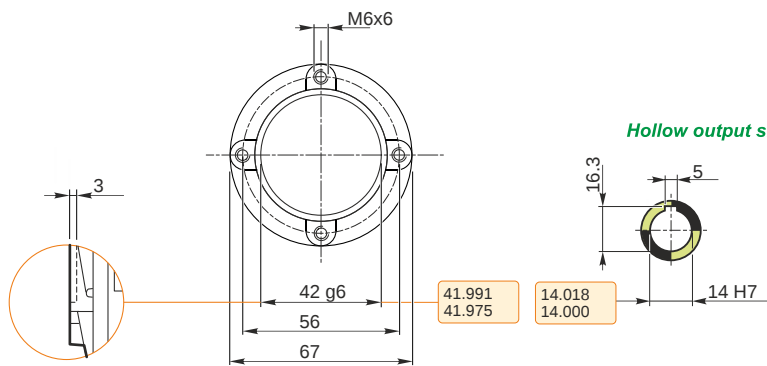
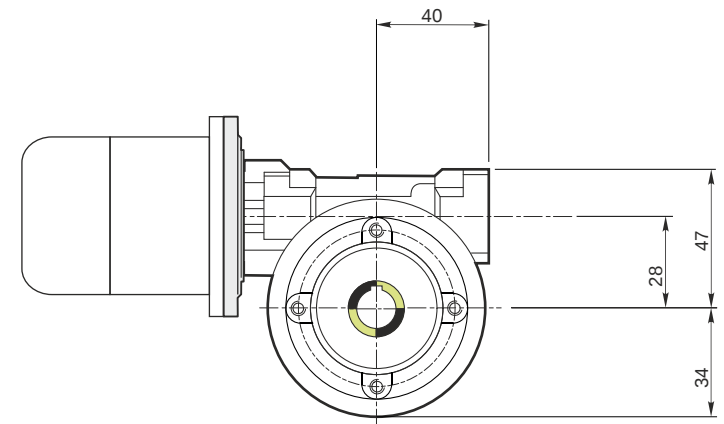
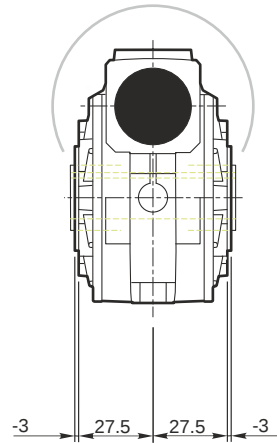
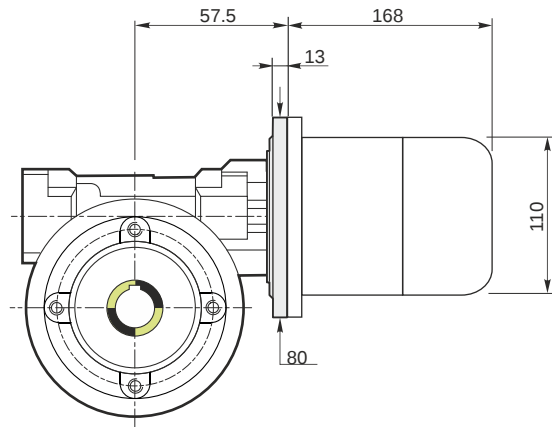

M RS 28 PC 40 56 B14 AC 14 MT 0.09 kW 56 B4 B14 X3 B3

Mounting positions

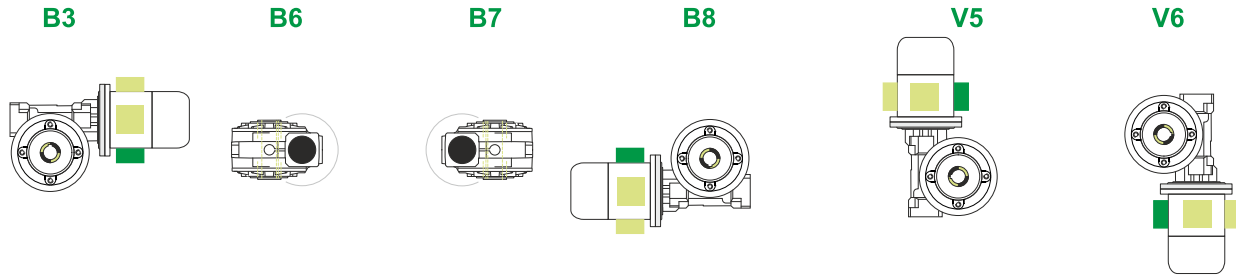

Terminal box position

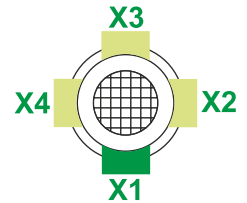

0.03



← Oil quantity [litres]

Lubricant type: Long life synthetic oil ISO VG320

Direction of rotation

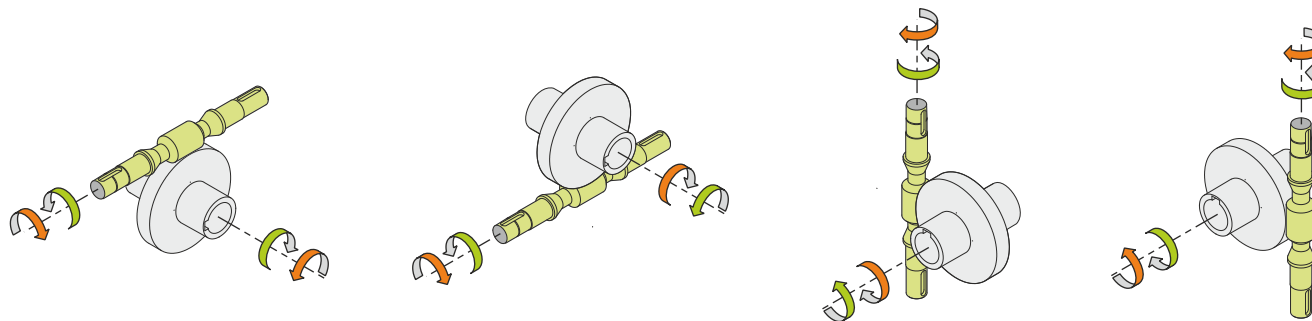

Weight

Gear unit [kg]	1.1
Electric motor [kg]	2.6

Gearing data

Axial module	1.1
Number of starts	1
Lead angle	5° 14'
Pressure angle	20°

Backdriving

Static self-locking
Slow back-driving in case of vibrations
Low dynamic back-driving

M RS 28 PC 40 56 B14 AC 14 MT 0.09 kW 56 B4 B14 X3 B3