

Input data

System of measurement		Metric
Input type		Gear motor
Input speed	[rpm]	1400
Output speed	[rpm]	25
Ratio (i=)		56
Frequency	[Hz]	50
Input options		IEC
Requested input power	[kW]	0.18
Service factor		1
Rated Power P1	[kW]	0.18

Output data

Gear unit **M RS 40 PC 56 63 B14 AC 19 MT 0.18 kW 63 B4 B14 X3 B3**

Type		RS - Worm speed reducers
Input type		M
Size		40
Ratio (i=)		56
Input flange		B14
Mounting position		B3
Input speed	[rpm]	1400
Output speed	[rpm]	25
Rated output torque	[Nm]	38.51
Service Factor		1
Efficiency		0.56
Inertia moment	[kgm ²]	0.000018

Gear unit configuration

Output shaft		Hollow output shaft
Fixing		Shaft mounting
Version		PC

Output radial and axial loads

Ball bearings output radial load	[N]	1800
Taper bearings output radial load	[N]	2500
Ball bearings output axial load	[N]	360
Taper bearings output axial load	[N]	500

Accessories

Hollow output shaft		AC 19
---------------------	--	-------

Electric motor

Size		63 B4
Poles		4
Power	[kW]	0.18

Electric motor configuration

Motor flange		B14
Terminal box position		X3

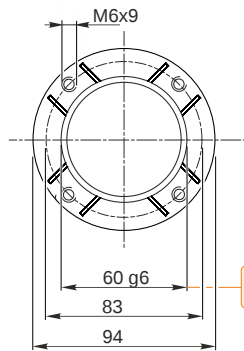
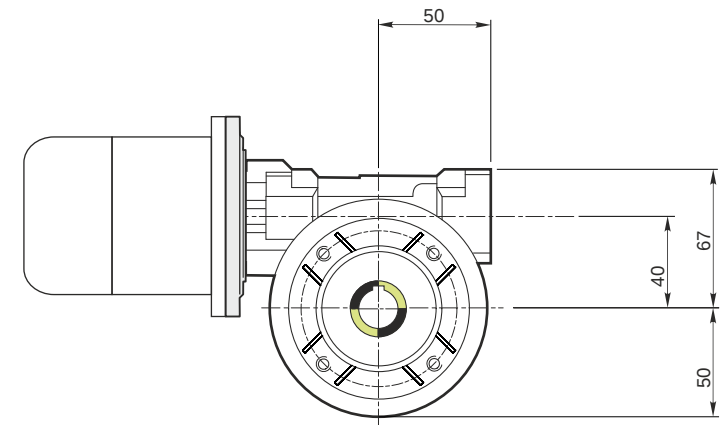
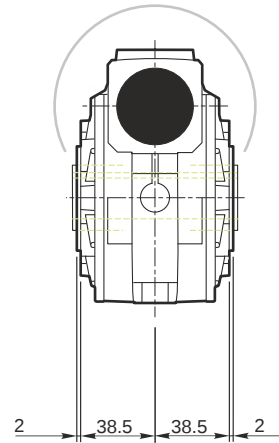
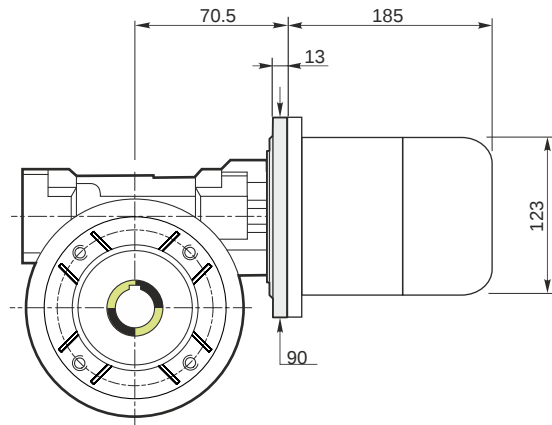

Hollow output shaft

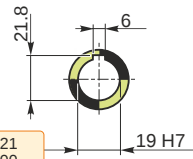

59.99
59.971

19.021
19.000

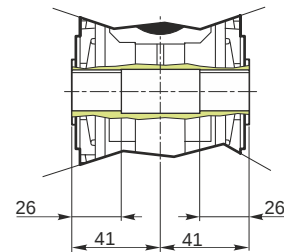

Mounting positions

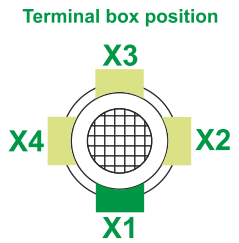
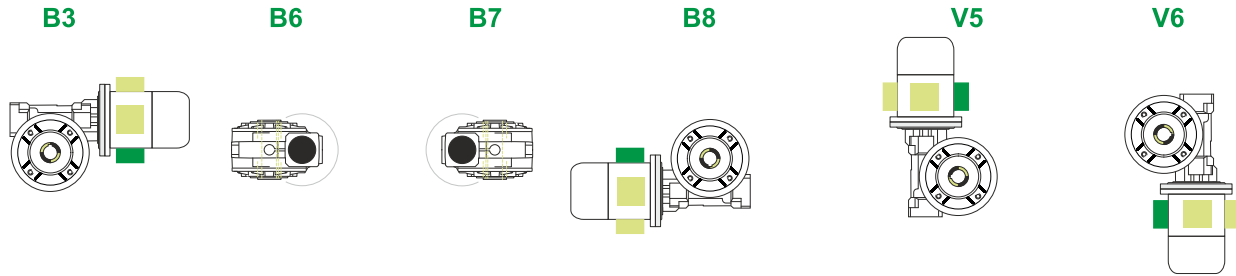

0.08



← Oil quantity [litres]

Lubricant type: Long life synthetic oil ISO VG320

Direction of rotation

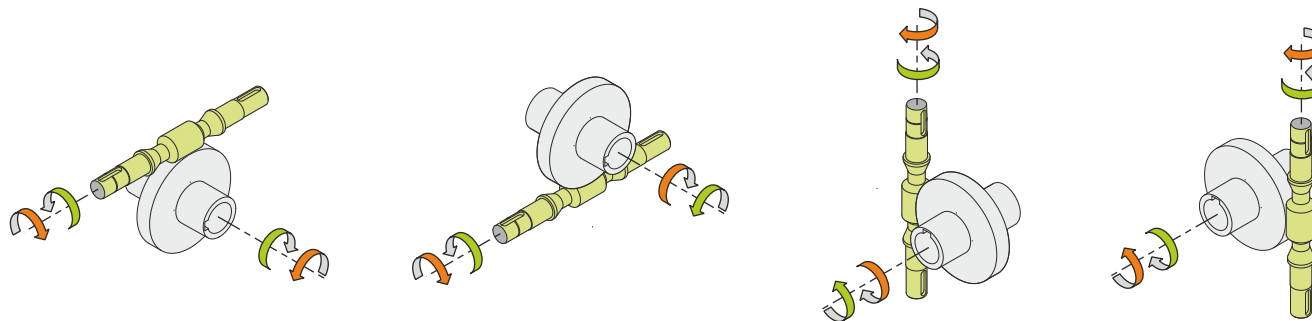

Weight

Gear unit [kg]	2.5
Electric motor [kg]	4.3

Gearing data

Axial module	1.1
Number of starts	1
Lead angle	3° 25'
Pressure angle	20°

Backdriving

Static self-locking
Slow back-driving in case of vibrations
Low dynamic back-driving

M RS 40 PC 56 63 B14 AC 19 MT 0.18 kW 63 B4 B14 X3 B3