

Input data

System of measurement		Metric
Input type		Gear motor
Input speed	[rpm]	1400
Output speed	[rpm]	200
Ratio (i=)		7
Frequency	[Hz]	50
Input options		IEC
Requested input power	[kW]	0.75
Service factor		2.4
Rated Power P1	[kW]	1.83

Output data

Gear unit **M RS 50 PC 7 80 B14 AC 24 MT 0.75 kW 80 B4 B14 X3 B3**

Type		RS - Worm speed reducers
Input type		M
Size		50
Ratio (i=)		7
Input flange		B14
Mounting position		B3
Input speed	[rpm]	1400
Output speed	[rpm]	200
Rated output torque	[Nm]	30.8
Service Factor		2.4
Efficiency		0.86
Inertia moment	[kgm ²]	0.000061

Gear unit configuration

Output shaft		Hollow output shaft
Fixing		Shaft mounting
Version		PC

Output radial and axial loads

Ball bearings output radial load	[N]	1250
Taper bearings output radial load	[N]	1750
Ball bearings output axial load	[N]	250
Taper bearings output axial load	[N]	350

Accessories

Hollow output shaft		AC 24
---------------------	--	-------

Electric motor

Size		80 B4
Poles		4
Power	[kW]	0.75

Electric motor configuration

Motor flange		B14
Terminal box position		X3

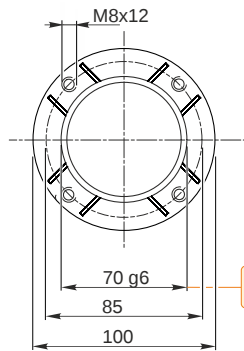
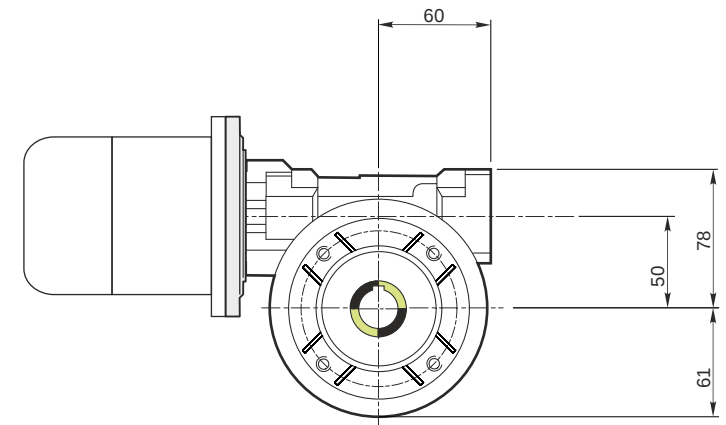
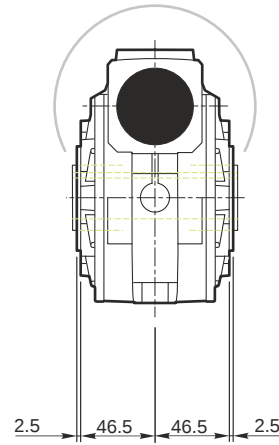
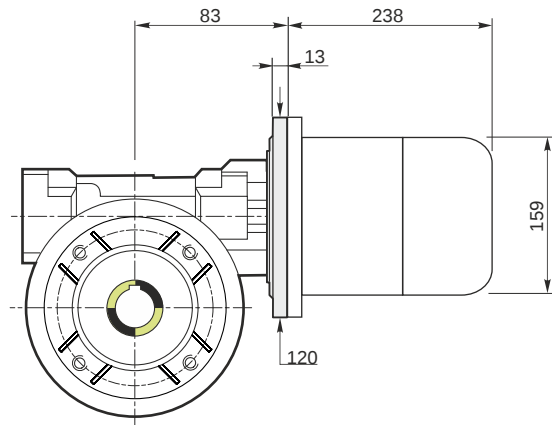

Hollow output shaft

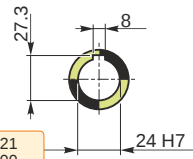

69.99
69.971

24.021
24.000

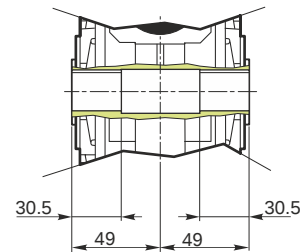

Mounting positions

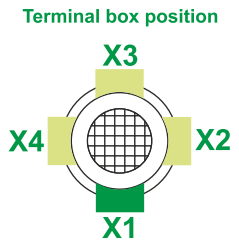
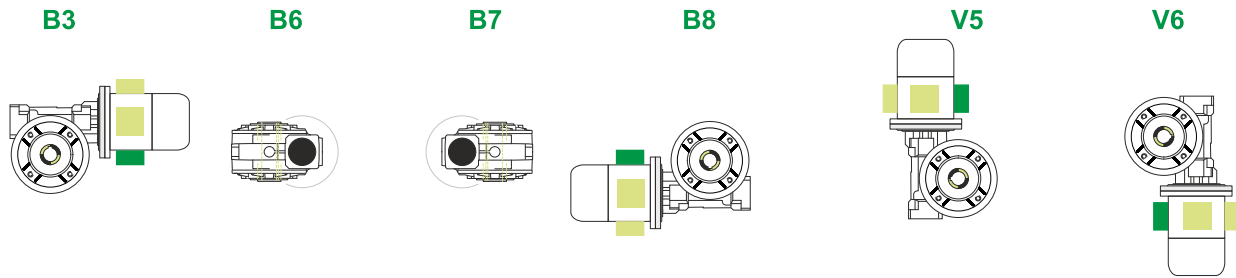

0.13



← Oil quantity [litres]

Lubricant type: Long life synthetic oil ISO VG320

Direction of rotation

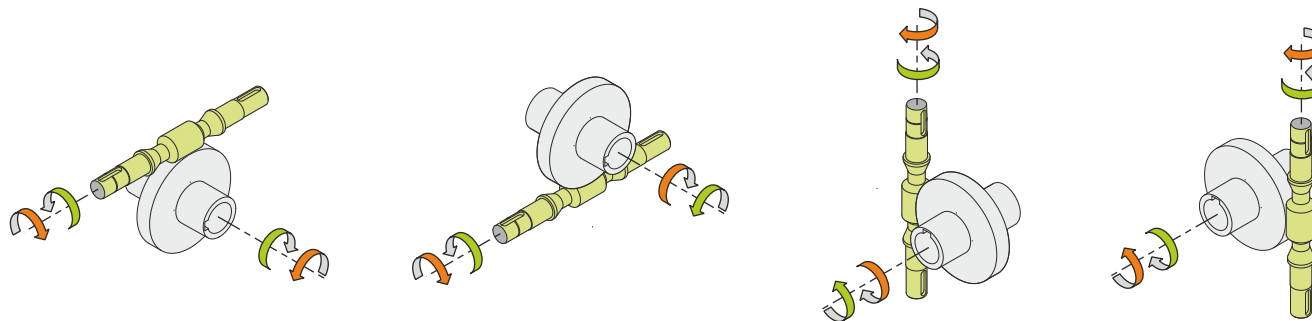

Weight

Gear unit [kg]	3.8
Electric motor [kg]	9.8

Gearing data

Axial module	2.7
Number of starts	
Lead angle	23° 52'
Pressure angle	20°

Backdriving

- Static back-driving
- Quick back-driving
- Dynamic back-driving

M RS 50 PC 7 80 B14 AC 24 MT 0.75 kW 80 B4 B14 X3 B3