

### Input data

System of measurement		Metric
Input type		Gear motor
Input speed	[rpm]	1400
Output speed	[rpm]	35
Ratio (i=)		40
Frequency	[Hz]	50
Input options		IEC
Requested input power	[kW]	0.37
Service factor		1.1
Rated Power P1	[kW]	0.41

### Output data

**Gear unit** **M RS 50 PC 40 71 B14 AC 24 MT 0.37 kW 71 B4 B14 X3 B3**

Type		RS - Worm speed reducers
Input type		M
Size		50
Ratio (i=)		40
Input flange		B14
Mounting position		B3
Input speed	[rpm]	1400
Output speed	[rpm]	35
Rated output torque	[Nm]	64.61
Service Factor		1.1
Efficiency		0.64
Inertia moment	[kgm <sup>2</sup> ]	0.000047

#### Gear unit configuration

Output shaft		Hollow output shaft
Fixing		Shaft mounting
Version		PC

#### Output radial and axial loads

Ball bearings output radial load	[N]	2300
Taper bearings output radial load	[N]	3400
Ball bearings output axial load	[N]	460
Taper bearings output axial load	[N]	680

#### Accessories

Hollow output shaft		AC 24
---------------------	--	-------

#### Electric motor

Size		71 B4
Poles		4
Power	[kW]	0.37

#### Electric motor configuration

Motor flange		B14
Terminal box position		X3

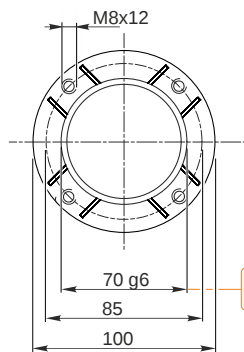
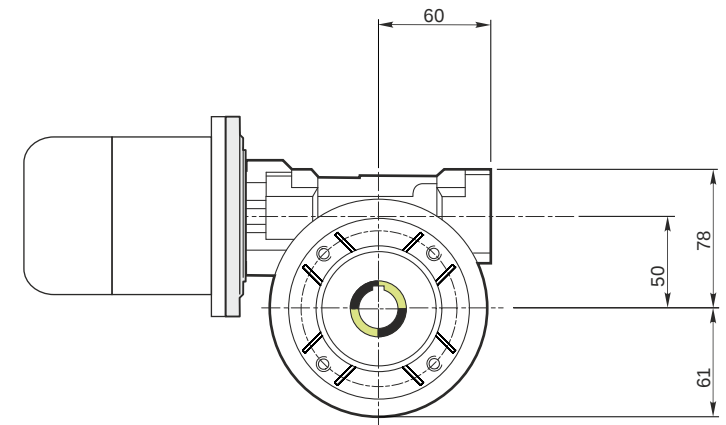
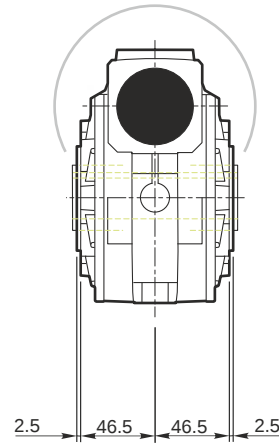
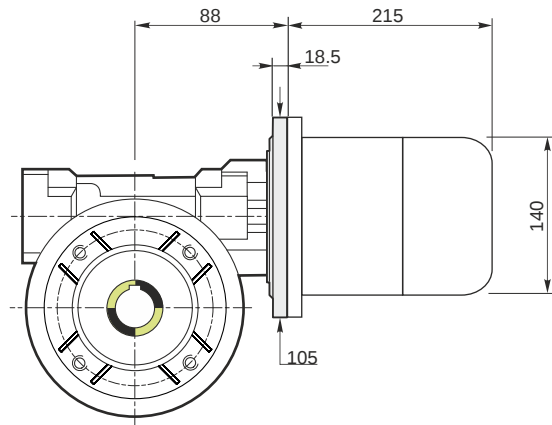

69.99  
69.971

24.021  
24.000

*Hollow output shaft*

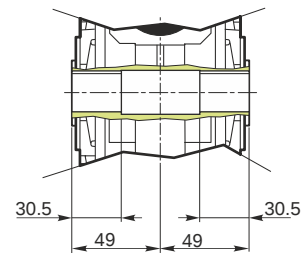
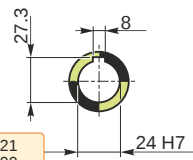

### Mounting positions

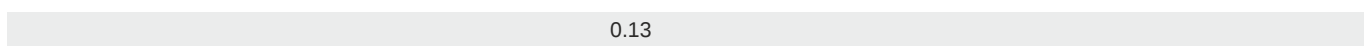
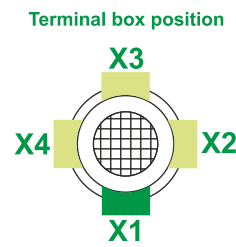
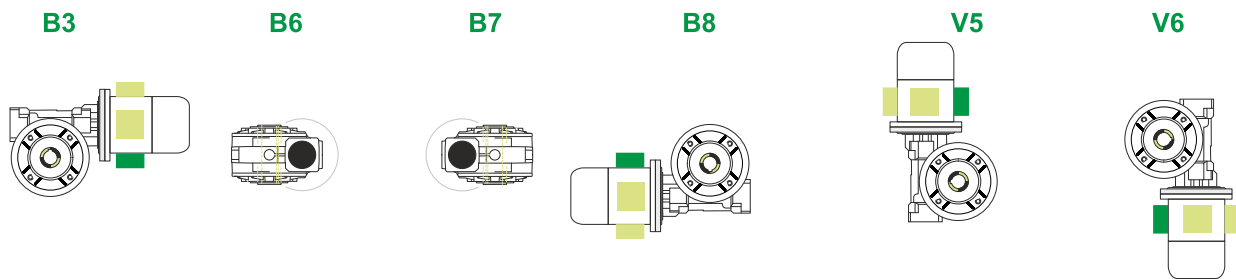

← Oil quantity [litres]

Lubricant type: Long life synthetic oil ISO VG320

### Direction of rotation

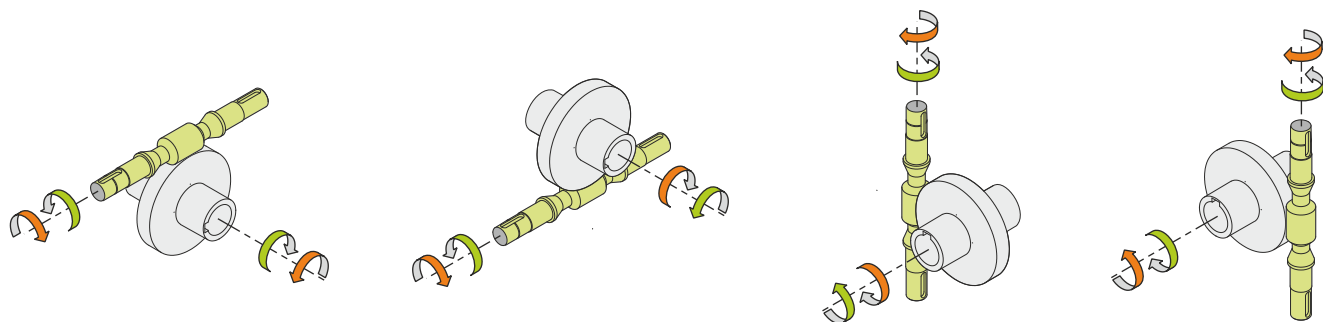

### Weight

Gear unit [kg]	3.8
Electric motor [kg]	6.2

### Gearing data

Axial module	1.9
Number of starts	1
Lead angle	4° 31'
Pressure angle	20°

### Backdriving

Static self-locking  
Slow back-driving in case of vibrations  
Low dynamic back-driving