

Input data

System of measurement		Metric
Input type		Gear motor
Input speed	[rpm]	1400
Output speed	[rpm]	28.57
Ratio (i=)		49
Frequency	[Hz]	50
Input options		IEC
Requested input power	[kW]	0.37
Service factor		1
Rated Power P1	[kW]	0.37

Output data

Gear unit **M RS 50 PC 49 71 B14 AC 24 MT 0.37 kW 71 B4 B14 X3 B3**

Type		RS - Worm speed reducers
Input type		M
Size		50
Ratio (i=)		49
Input flange		B14
Mounting position		B3
Input speed	[rpm]	1400
Output speed	[rpm]	28.57
Rated output torque	[Nm]	76.68
Service Factor		1
Efficiency		0.62
Inertia moment	[kgm ²]	0.000047

Gear unit configuration

Output shaft		Hollow output shaft
Fixing		Shaft mounting
Version		PC

Output radial and axial loads

Ball bearings output radial load	[N]	2400
Taper bearings output radial load	[N]	3600
Ball bearings output axial load	[N]	480
Taper bearings output axial load	[N]	720

Accessories

Hollow output shaft		AC 24
---------------------	--	-------

Electric motor

Size		71 B4
Poles		4
Power	[kW]	0.37

Electric motor configuration

Motor flange		B14
Terminal box position		X3

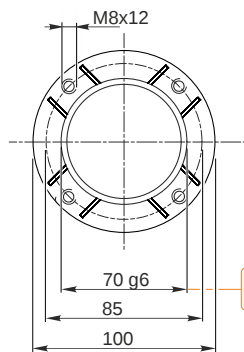
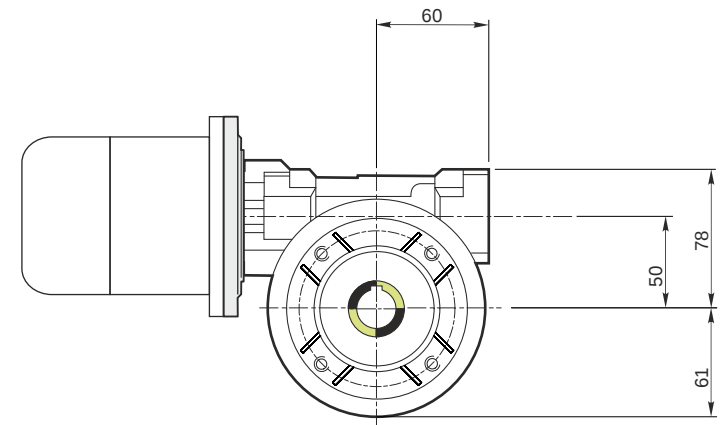
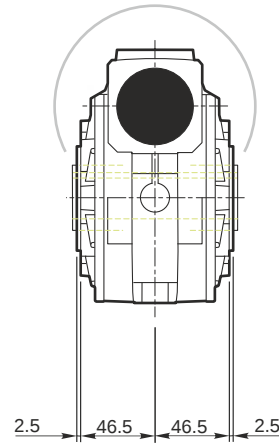
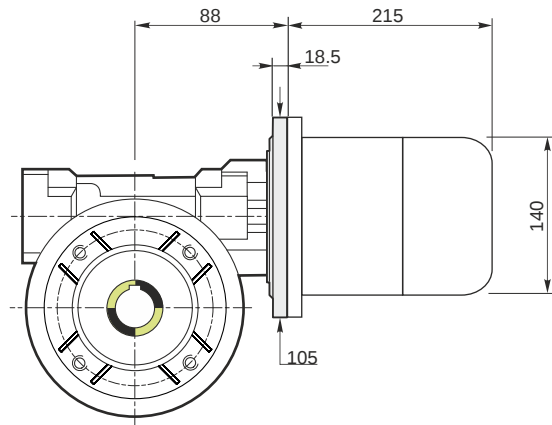

Hollow output shaft

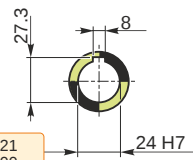

69.99
69.971

24.021
24.000

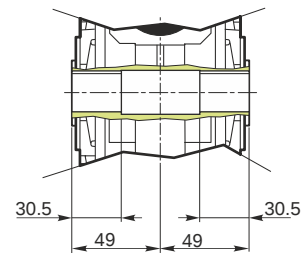

Mounting positions

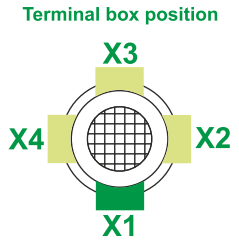
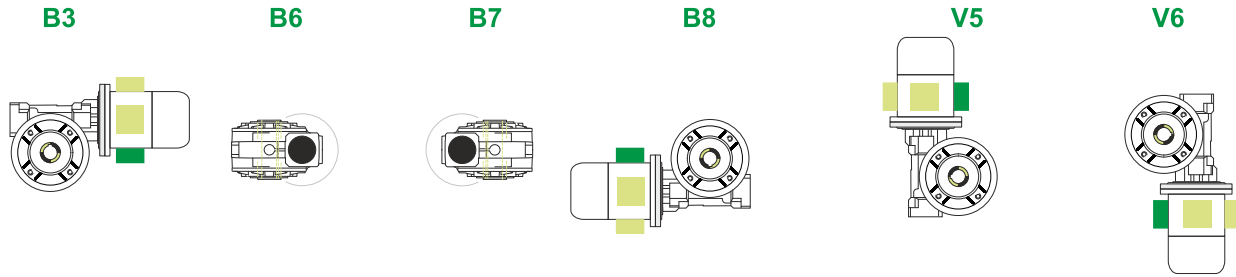

0.13



← Oil quantity [litres]

Lubricant type: Long life synthetic oil ISO VG320

Direction of rotation



Weight

Gear unit [kg]	3.8
Electric motor [kg]	6.2

Gearing data

Axial module	1.6
Number of starts	1
Lead angle	4° 14'
Pressure angle	20°

Backdriving

Static self-locking
Slow back-driving in case of vibrations
Low dynamic back-driving

M RS 50 PC 49 71 B14 AC 24 MT 0.37 kW 71 B4 B14 X3 B3