

Input data

System of measurement		Metric
Input type		Gear motor
Input speed	[rpm]	1400
Output speed	[rpm]	35
Ratio (i=)		40
Frequency	[Hz]	50
Input options		IEC
Requested input power	[kW]	1.1
Service factor		1.1
Rated Power P1	[kW]	1.23

Output data

Gear unit **M RS 70 PC 40 90 B14 AC 28 MT 1.1 kW 90 S4 B14 X3 B3**

Type		RS - Worm speed reducers
Input type		M
Size		70
Ratio (i=)		40
Input flange		B14
Mounting position		B3
Input speed	[rpm]	1400
Output speed	[rpm]	35
Rated output torque	[Nm]	213.1
Service Factor		1.1
Efficiency		0.71
Inertia moment	[kgm ²]	0.000245

Gear unit configuration

Output shaft		Hollow output shaft
Fixing		Shaft mounting
Version		PC

Output radial and axial loads

Ball bearings output radial load	[N]	4500
Taper bearings output radial load	[N]	6100
Ball bearings output axial load	[N]	900
Taper bearings output axial load	[N]	1220

Accessories

Hollow output shaft		AC 28
---------------------	--	-------

Electric motor

Size		90 S4
Poles		4
Power	[kW]	1.1

Electric motor configuration

Motor flange		B14
Terminal box position		X3

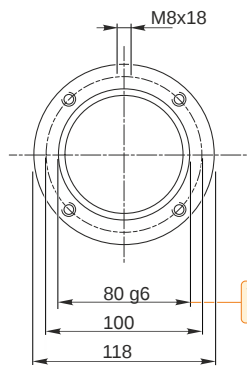
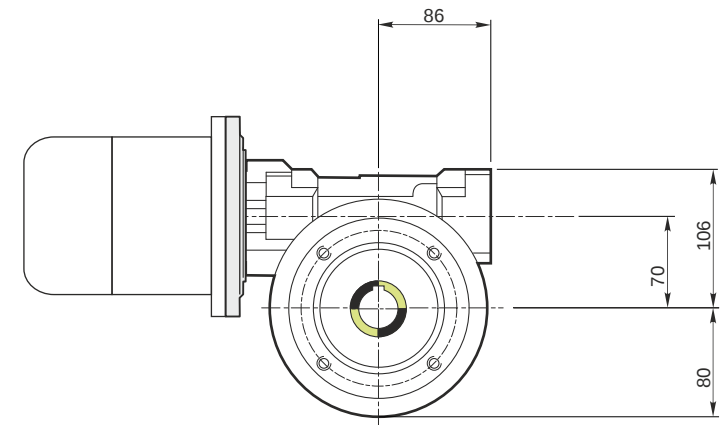
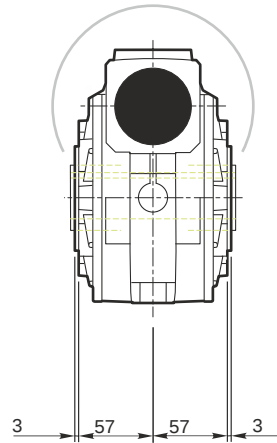
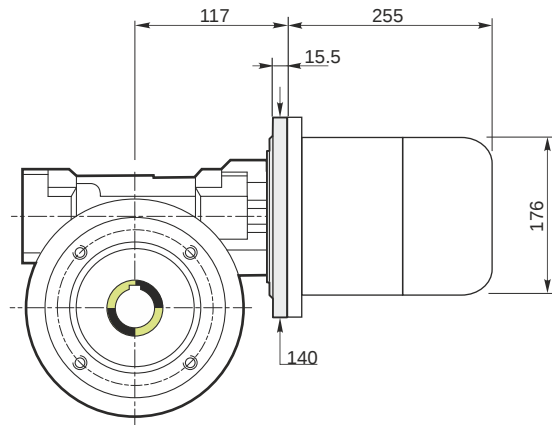

Hollow output shaft

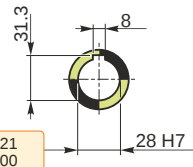

79.99
79.971

28.021
28.000

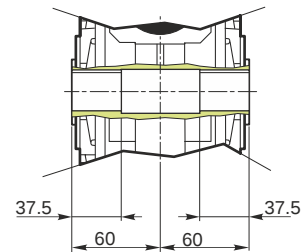

M RS 70 PC 40 90 B14 AC 28 MT 1.1 kW 90 S4 B14 X3 B3

Mounting positions

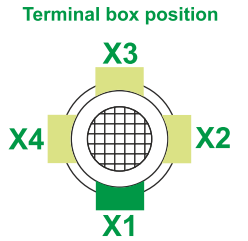
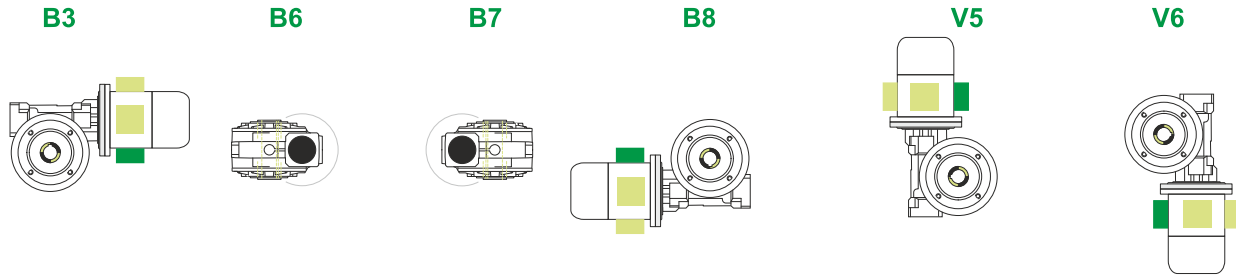

0.35



← Oil quantity [litres]

Lubricant type: Long life synthetic oil ISO VG320

Direction of rotation

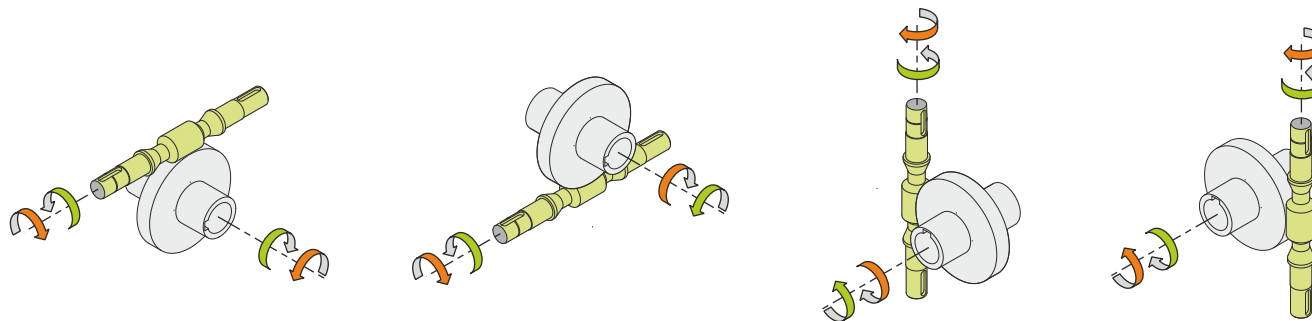

Weight

Gear unit [kg]	9
Electric motor [kg]	12

Gearing data

Axial module	2.8
Number of starts	1
Lead angle	5° 42'
Pressure angle	20°

Backdriving

Static self-locking
Slow back-driving in case of vibrations
Low dynamic back-driving