

### Input data

System of measurement		Metric
Input type		Gear motor
Input speed	[rpm]	1400
Output speed	[rpm]	25
Ratio (i=)		56
Frequency	[Hz]	50
Input options		IEC
Requested input power	[kW]	0.75
Service factor		1
Rated Power P1	[kW]	0.74

### Output data

**Gear unit** **M RS 70 PC 56 80 B14 AC 28 MT 0.75 kW 80 B4 B14 X3 B3**

Type		RS - Worm speed reducers
Input type		M
Size		70
Ratio (i=)		56
Input flange		B14
Mounting position		B3
Input speed	[rpm]	1400
Output speed	[rpm]	25
Rated output torque	[Nm]	183.36
Service Factor		1
Efficiency		0.64
Inertia moment	[kgm <sup>2</sup> ]	0.000244

#### Gear unit configuration

Output shaft		Hollow output shaft
Fixing		Shaft mounting
Version		PC

#### Output radial and axial loads

Ball bearings output radial load	[N]	5500
Taper bearings output radial load	[N]	7300
Ball bearings output axial load	[N]	1100
Taper bearings output axial load	[N]	1460

#### Accessories

Hollow output shaft		AC 28
---------------------	--	-------

#### Electric motor

Size		80 B4
Poles		4
Power	[kW]	0.75

#### Electric motor configuration

Motor flange		B14
Terminal box position		X3

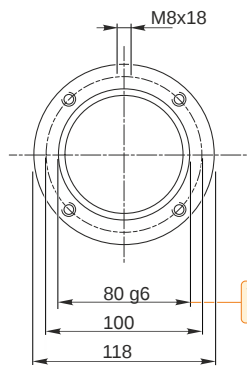
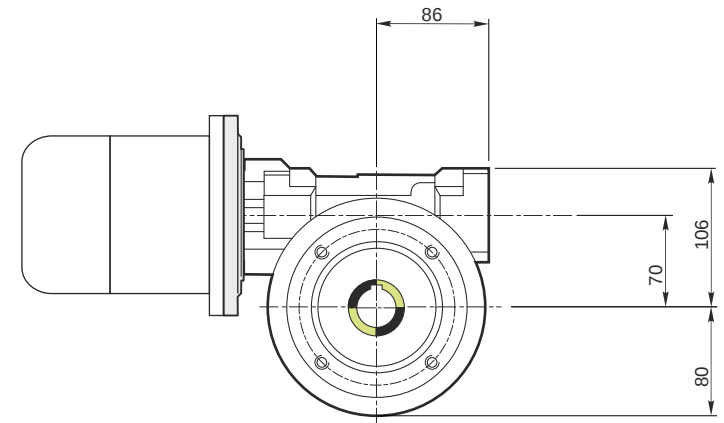
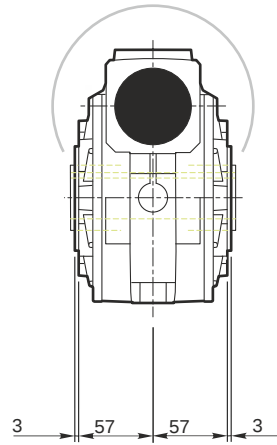
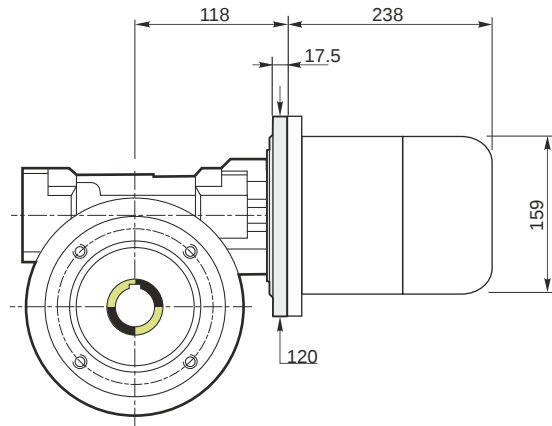

Hollow output shaft

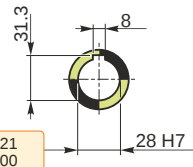

79.99  
79.971

28.021  
28.000

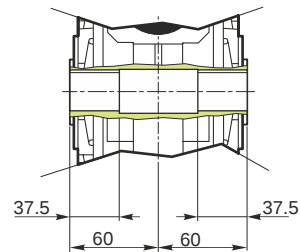

**Mounting positions**

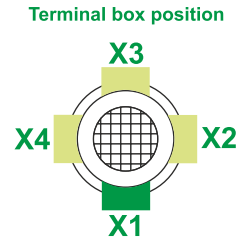
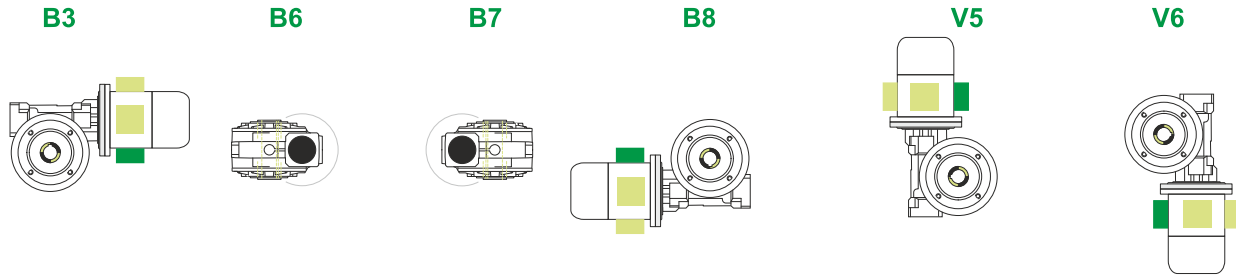

0.35



← Oil quantity [litres]

Lubricant type: Long life synthetic oil ISO VG320

**Direction of rotation**

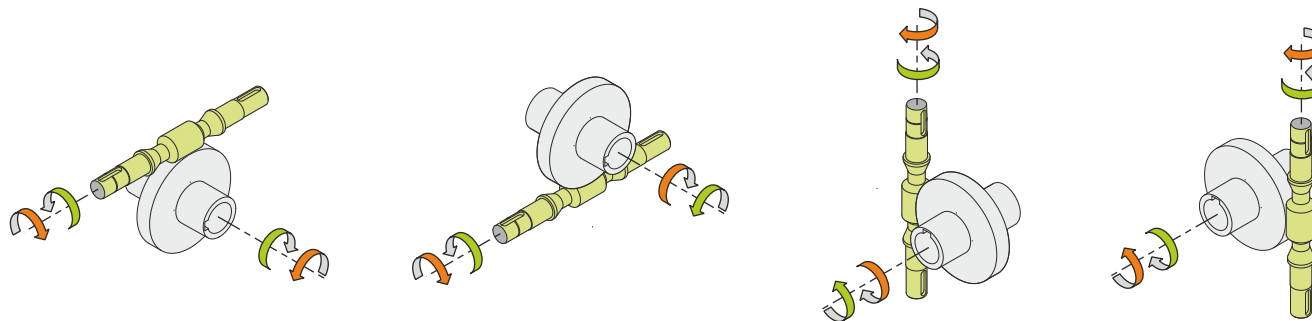

**Weight**

Gear unit [kg]	9
Electric motor [kg]	9.8

**Gearing data**

Axial module	2
Number of starts	1
Lead angle	4° 05'
Pressure angle	20°

**Backdriving**

Static self-locking  
Slow back-driving in case of vibrations  
Low dynamic back-driving