

Input data

System of measurement		Metric
Input type		Gear motor
Input speed	[rpm]	1400
Output speed	[rpm]	28.57
Ratio (i=)		49
Frequency	[Hz]	50
Input options		IEC
Requested input power	[kW]	1.1
Service factor		1.3
Rated Power P1	[kW]	1.41

Output data

Gear unit **M RS 85 PC 49 90 B14 AC 32 MT 1.1 kW 90 S4 B14 X3 B3**

Type		RS - Worm speed reducers
Input type		M
Size		85
Ratio (i=)		49
Input flange		B14
Mounting position		B3
Input speed	[rpm]	1400
Output speed	[rpm]	28.57
Rated output torque	[Nm]	246.34
Service Factor		1.3
Efficiency		0.67
Inertia moment	[kgm ²]	0.000342

Gear unit configuration

Output shaft		Hollow output shaft
Fixing		Shaft mounting
Version		PC

Output radial and axial loads

Ball bearings output radial load	[N]	6300
Taper bearings output radial load	[N]	8400
Ball bearings output axial load	[N]	1260
Taper bearings output axial load	[N]	1680

Accessories

Hollow output shaft		AC 32
---------------------	--	-------

Electric motor

Size		90 S4
Poles		4
Power	[kW]	1.1

Electric motor configuration

Motor flange		B14
Terminal box position		X3

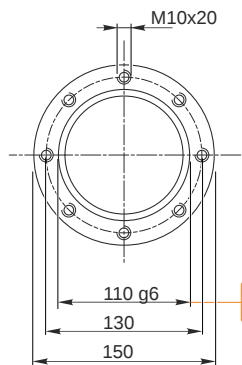
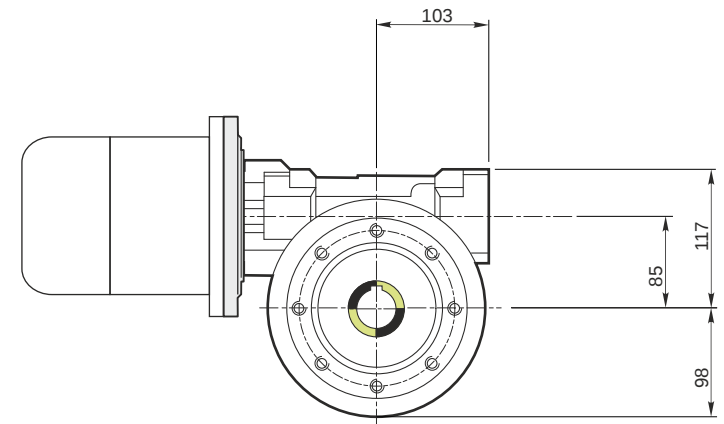
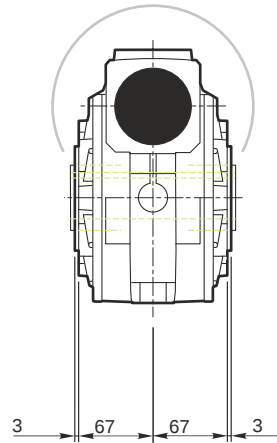
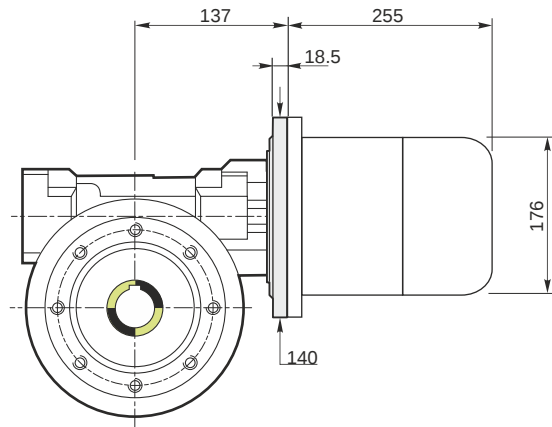

109.988
109.966

32.025
32.000

Hollow output shaft

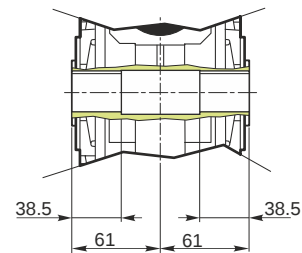
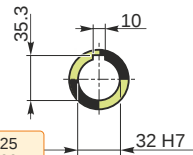

M RS 85 PC 49 90 B14 AC 32 MT 1.1 kW 90 S4 B14 X3 B3

Mounting positions

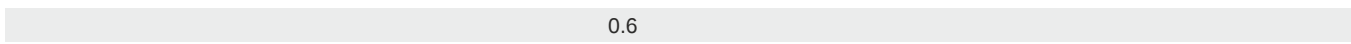
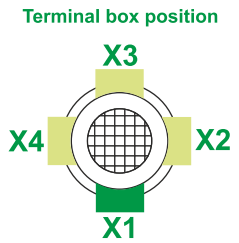
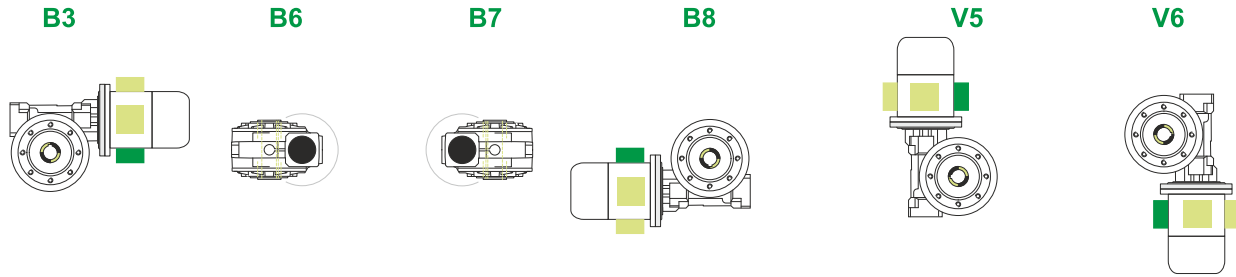

← Oil quantity [litres]

Lubricant type: Long life synthetic oil ISO VG320

Direction of rotation



Weight

Gear unit [kg]	13.5
Electric motor [kg]	12

Gearing data

Axial module	2.8
Number of starts	1
Lead angle	4° 52'
Pressure angle	20°

Backdriving

Static self-locking
Slow back-driving in case of vibrations
Low dynamic back-driving

M RS 85 PC 49 90 B14 AC 32 MT 1.1 kW 90 S4 B14 X3 B3