

Input data

System of measurement		Metric
Input type		Gear motor
Input speed	[rpm]	1400
Output speed	[rpm]	50
Ratio (i=)		28
Frequency	[Hz]	50
Input options		IEC
Requested input power	[kW]	4
Service factor		1.1
Rated Power P1	[kW]	4.42

Output data

Gear unit M RS 110 PC 28 112 B14 AC 42 MT 4 kW 112 A4 B14 X3 B3

Type		RS - Worm speed reducers
Input type		M
Size		110
Ratio (i=)		28
Input flange		B14
Mounting position		B3
Input speed	[rpm]	1400
Output speed	[rpm]	50
Rated output torque	[Nm]	580.64
Service Factor		1.1
Efficiency		0.76
Inertia moment	[kgm ²]	0.001713

Gear unit configuration

Output shaft		Hollow output shaft
Fixing		Shaft mounting
Version		PC

Output radial and axial loads

Ball bearings output radial load	[N]	5900
Taper bearings output radial load	[N]	8000
Ball bearings output axial load	[N]	1180
Taper bearings output axial load	[N]	1600

Accessories

Hollow output shaft		AC 42
---------------------	--	-------

Electric motor

Size		112 A4
Poles		4
Power	[kW]	4

Electric motor configuration

Motor flange		B14
Terminal box position		X3

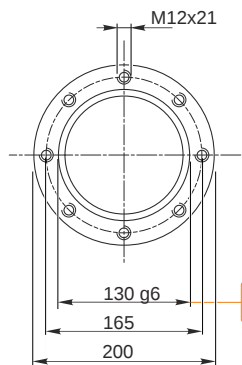
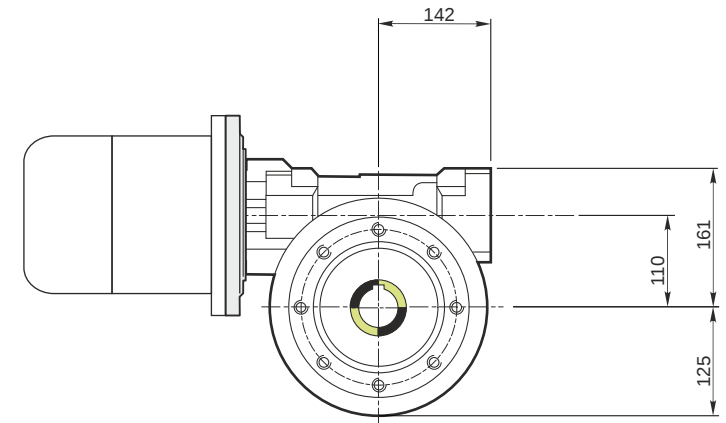
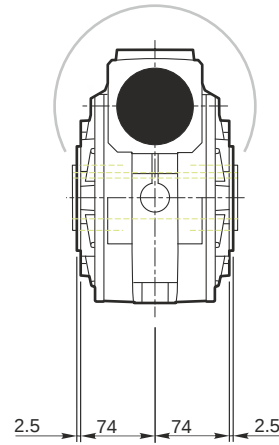
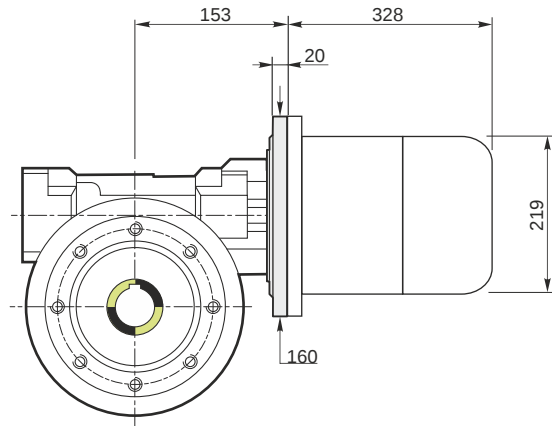

Hollow output shaft

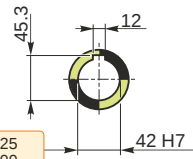

129.986
129.961

42.025
42.000

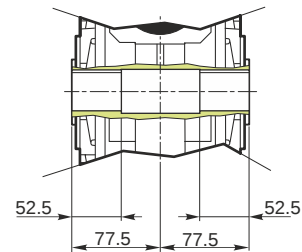

M RS 110 PC 28 112 B14 AC 42 MT 4 kW 112 A4 B14 X3 B3

Mounting positions

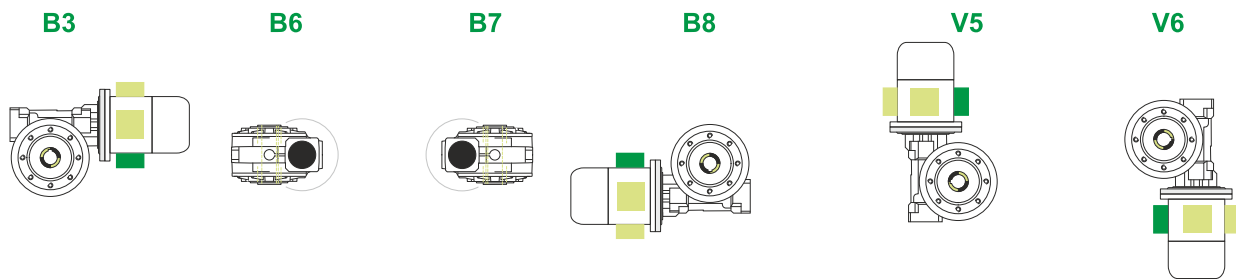

Terminal box position

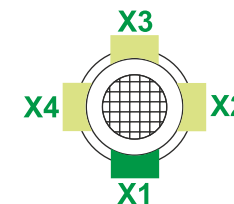

1.5



← Oil quantity [litres]

Lubricant type: Long life synthetic oil ISO VG320

Direction of rotation

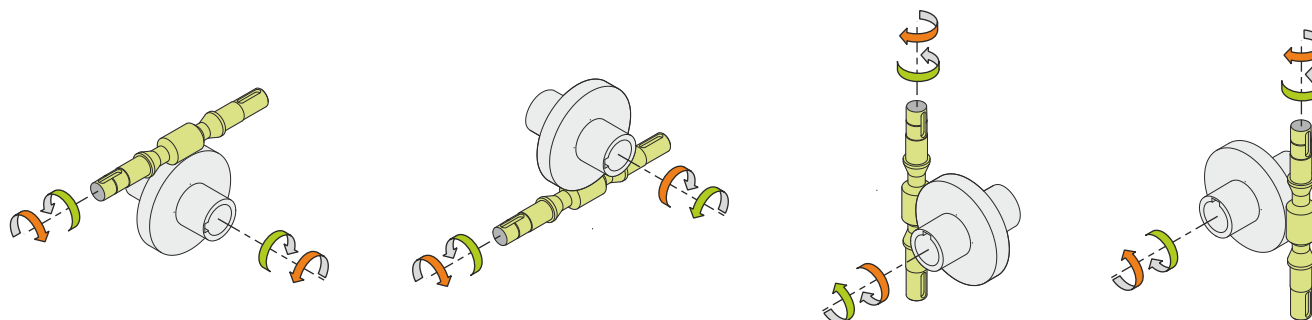

Weight

Gear unit [kg]	39
Electric motor [kg]	29

Gearing data

Axial module	6.1
Number of starts	1
Lead angle	7° 04'
Pressure angle	20°

Backdriving

Static self-locking
Slow back-driving in case of vibrations
Low dynamic back-driving