

Input data

System of measurement		Metric
Input type		Gear motor
Input speed	[rpm]	1400
Output speed	[rpm]	28.57
Ratio (i=)		49
Frequency	[Hz]	50
Input options		IEC
Requested input power	[kW]	2.2
Service factor		1.2
Rated Power P1	[kW]	2.66

Output data

Gear unit **M RS 110 PC 49 100 B14 AC 42 MT 2.2 kW 100 A4 B14 X3 B3**

Type		RS - Worm speed reducers
Input type		M
Size		110
Ratio (i=)		49
Input flange		B14
Mounting position		B3
Input speed	[rpm]	1400
Output speed	[rpm]	28.57
Rated output torque	[Nm]	522.1
Service Factor		1.2
Efficiency		0.71
Inertia moment	[kgm ²]	0.001691

Gear unit configuration

Output shaft		Hollow output shaft
Fixing		Shaft mounting
Version		PC

Output radial and axial loads

Ball bearings output radial load	[N]	7500
Taper bearings output radial load	[N]	10500
Ball bearings output axial load	[N]	1500
Taper bearings output axial load	[N]	2100

Accessories

Hollow output shaft		AC 42
---------------------	--	-------

Electric motor

Size		100 A4
Poles		4
Power	[kW]	2.2

Electric motor configuration

Motor flange		B14
Terminal box position		X3

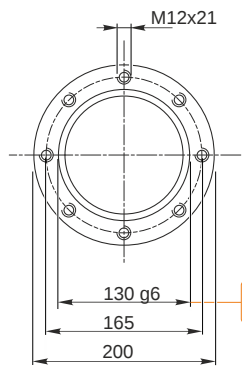
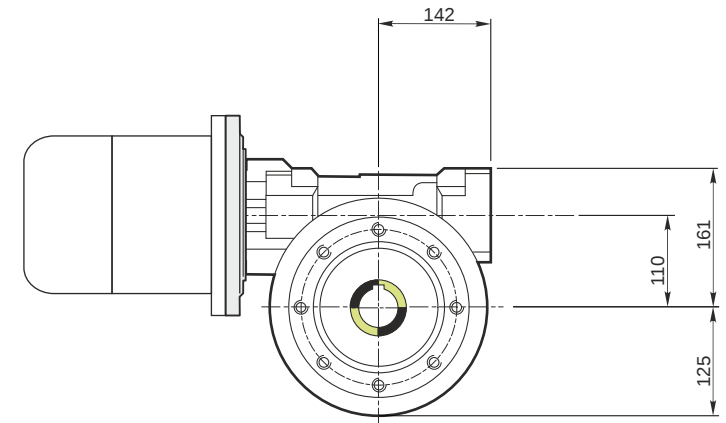
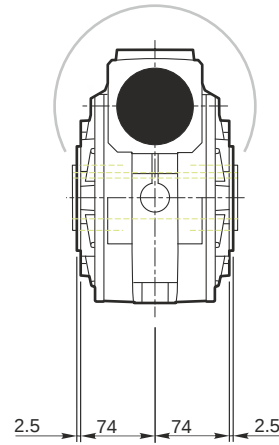
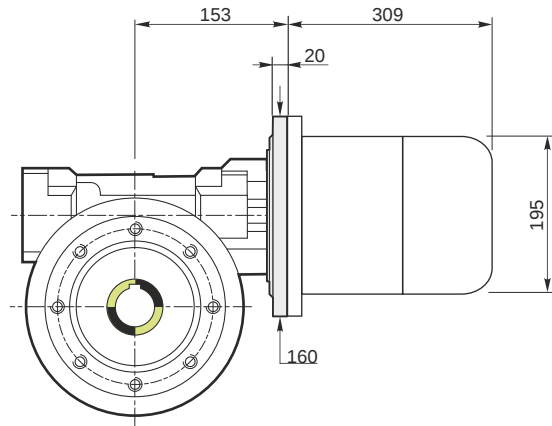

Hollow output shaft

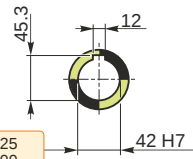

129.986
129.961

42.025
42.000

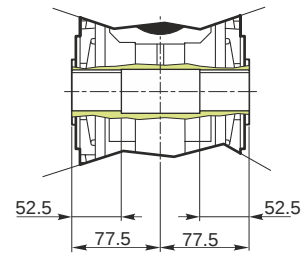

M RS 110 PC 49 100 B14 AC 42 MT 2.2 kW 100 A4 B14 X3 B3

Mounting positions

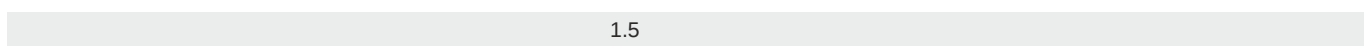
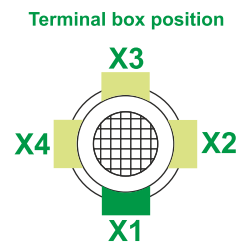
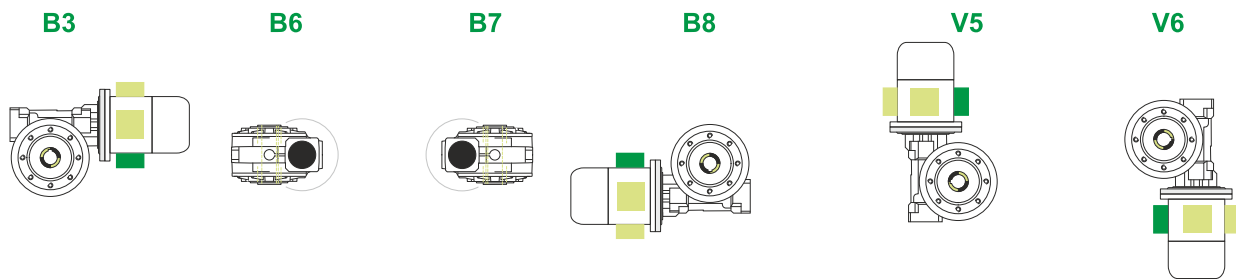

Lubricant type: Long life synthetic oil ISO VG320

Direction of rotation

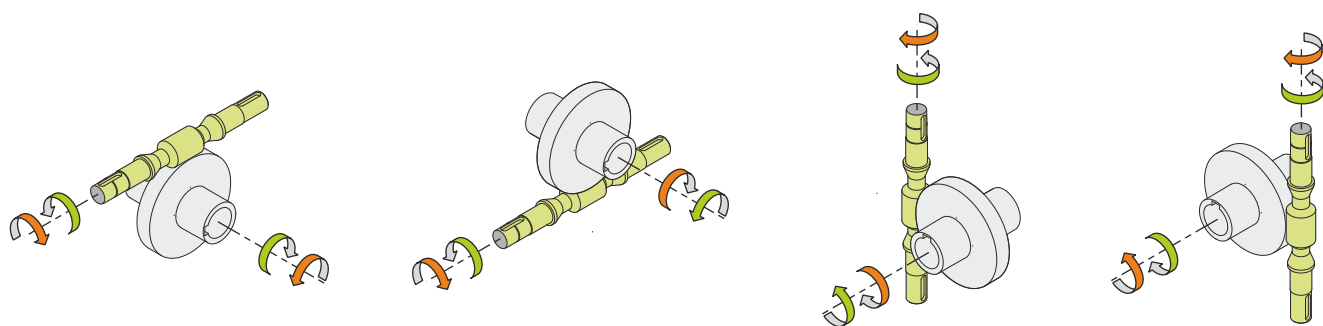

Weight

Gear unit [kg]	39
Electric motor [kg]	21

Gearing data

Axial module	3.6
Number of starts	1
Lead angle	4° 43'
Pressure angle	20°

Backdriving

Static self-locking
Slow back-driving in case of vibrations
Low dynamic back-driving

M RS 110 PC 49 100 B14 AC 42 MT 2.2 kW 100 A4 B14 X3 B3