

Input data

System of measurement		Metric
Input type		Gear motor
Input speed	[rpm]	1400
Output speed	[rpm]	20
Ratio (i=)		70
Frequency	[Hz]	50
Input options		IEC
Requested input power	[kW]	1.5
Service factor		1.3
Rated Power P1	[kW]	1.98

Output data

Gear unit **M RS 110 PC 70 90 B14 AC 42 MT 1.5 kW 90 L4 B14 X3 B3**

Type		RS - Worm speed reducers
Input type		M
Size		110
Ratio (i=)		70
Input flange		B14
Mounting position		B3
Input speed	[rpm]	1400
Output speed	[rpm]	20
Rated output torque	[Nm]	479.89
Service Factor		1.3
Efficiency		0.67
Inertia moment	[kgm ²]	0.001685

Gear unit configuration

Output shaft		Hollow output shaft
Fixing		Shaft mounting
Version		PC

Output radial and axial loads

Ball bearings output radial load	[N]	8000
Taper bearings output radial load	[N]	11100
Ball bearings output axial load	[N]	1600
Taper bearings output axial load	[N]	2220

Accessories

Hollow output shaft		AC 42
---------------------	--	-------

Electric motor

Size		90 L4
Poles		4
Power	[kW]	1.5

Electric motor configuration

Motor flange		B14
Terminal box position		X3

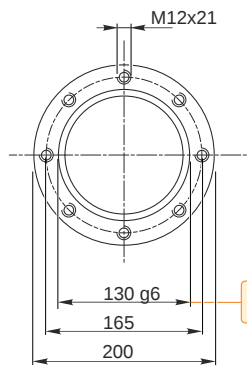
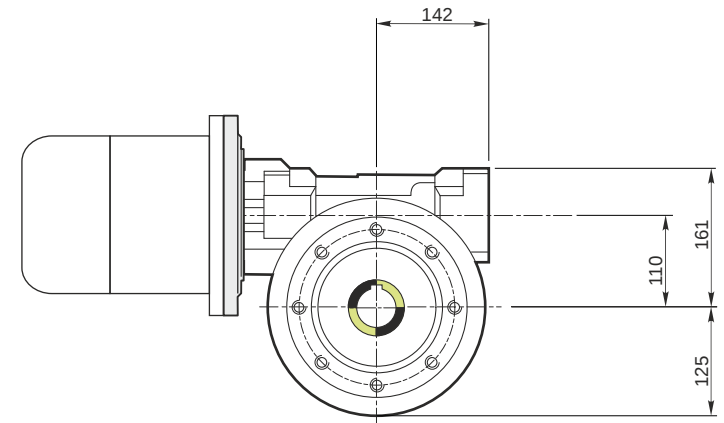
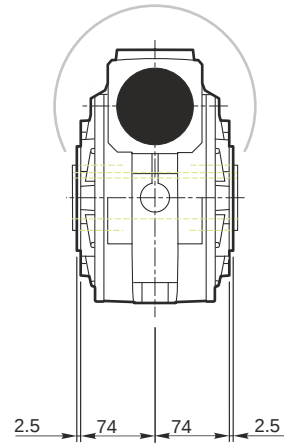
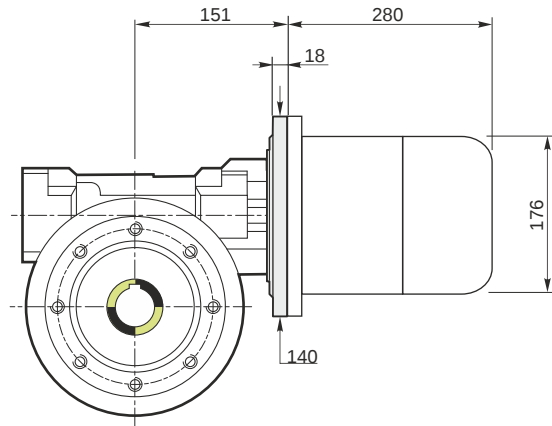

Hollow output shaft

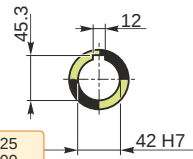

129.986
129.961

42.025
42.000

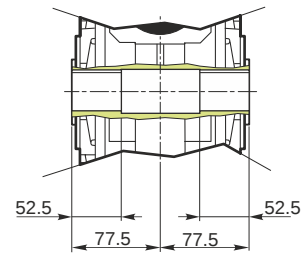

M RS 110 PC 70 90 B14 AC 42 MT 1.5 kW 90 L4 B14 X3 B3

Mounting positions

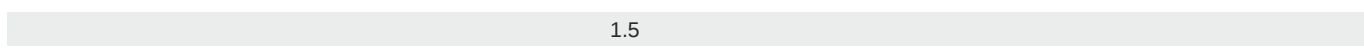
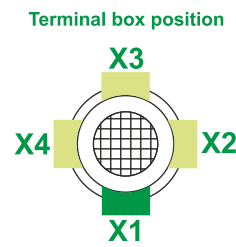
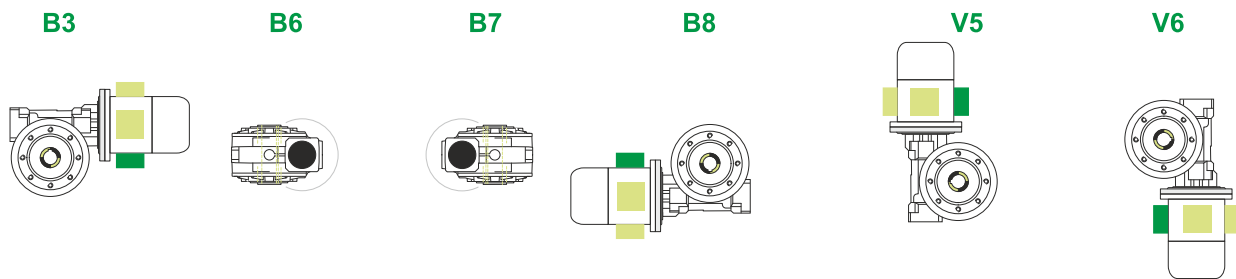

Lubricant type: Long life synthetic oil ISO VG320

Direction of rotation

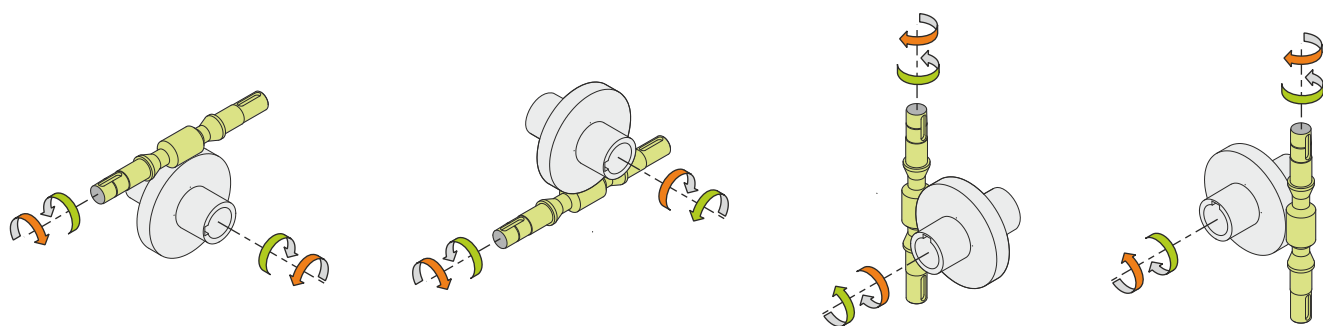

Weight

Gear unit [kg]	39
Electric motor [kg]	13.5

Gearing data

Axial module	2.6
Number of starts	1
Lead angle	3° 54'
Pressure angle	20°

Backdriving

Static self-locking
Slow back-driving in case of vibrations
Low dynamic back-driving

M RS 110 PC 70 90 B14 AC 42 MT 1.5 kW 90 L4 B14 X3 B3