

Input data

System of measurement		Metric
Input type		Gear motor
Input speed	[rpm]	1400
Output speed	[rpm]	14
Ratio (i=)		100
Frequency	[Hz]	50
Input options		IEC
Requested input power	[kW]	1.1
Service factor		1
Rated Power P1	[kW]	1.13

Output data

Gear unit **M RS 110 PC 100 90 B14 AC 42 MT 1.1 kW 90 S4 B14 X3 B3**

Type		RS - Worm speed reducers
Input type		M
Size		110
Ratio (i=)		100
Input flange		B14
Mounting position		B3
Input speed	[rpm]	1400
Output speed	[rpm]	14
Rated output torque	[Nm]	457.72
Service Factor		1
Efficiency		0.61
Inertia moment	[kgm ²]	0.001682

Gear unit configuration

Output shaft		Hollow output shaft
Fixing		Shaft mounting
Version		PC

Output radial and axial loads

Ball bearings output radial load	[N]	9800
Taper bearings output radial load	[N]	11100
Ball bearings output axial load	[N]	1960
Taper bearings output axial load	[N]	2220

Accessories

Hollow output shaft		AC 42
---------------------	--	-------

Electric motor

Size		90 S4
Poles		4
Power	[kW]	1.1

Electric motor configuration

Motor flange		B14
Terminal box position		X3

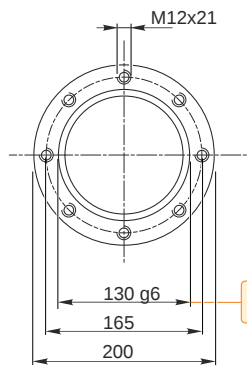
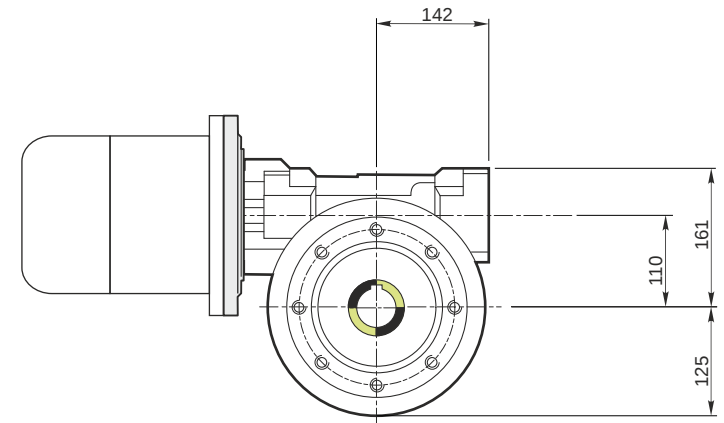
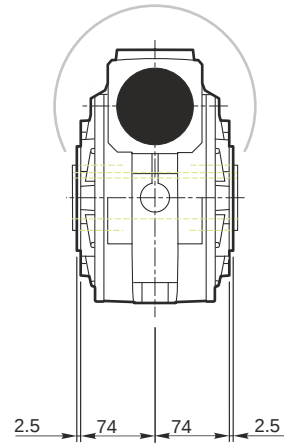
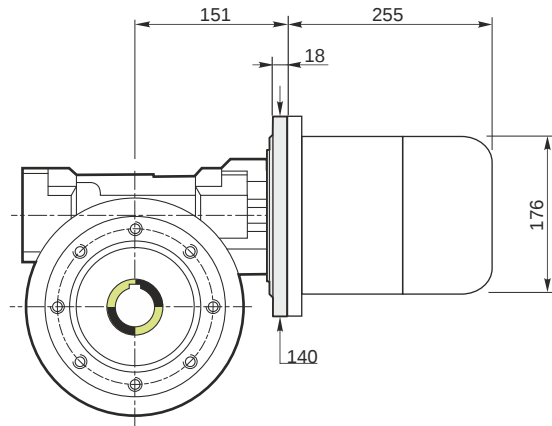

Hollow output shaft

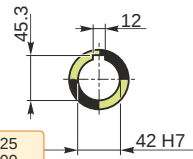

129.986
129.961

42.025
42.000

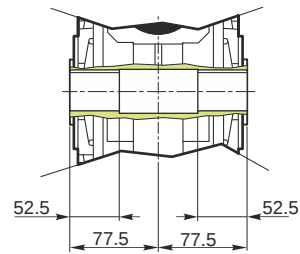

M RS 110 PC 100 90 B14 AC 42 MT 1.1 kW 90 S4 B14 X3 B3

Mounting positions

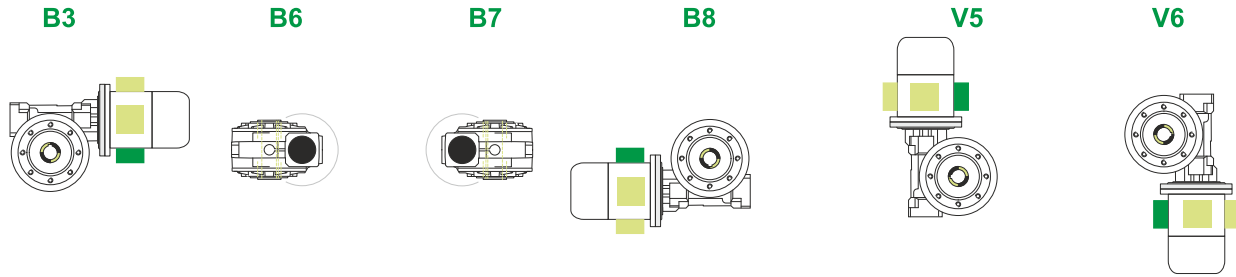

Terminal box position

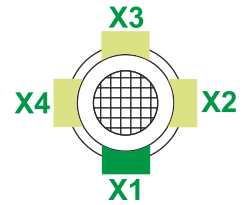

1.5



← Oil quantity [litres]

Lubricant type: Long life synthetic oil ISO VG320

Direction of rotation

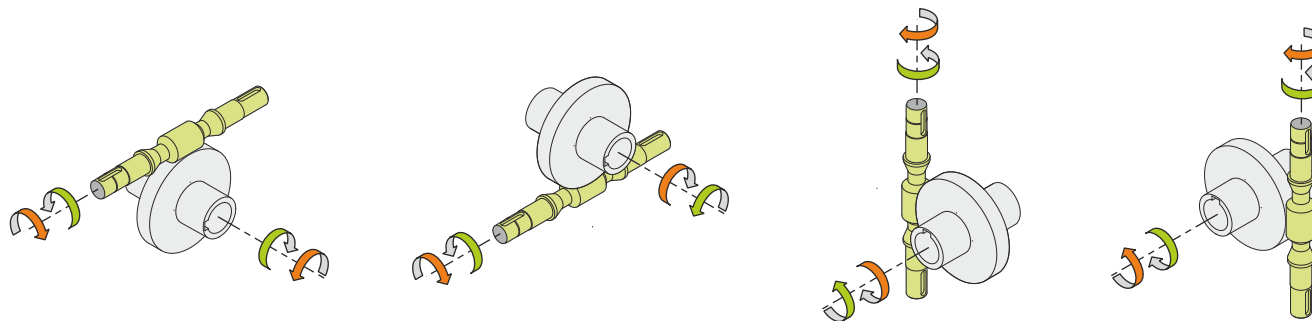

Weight

Gear unit [kg]	39
Electric motor [kg]	12

Gearing data

Axial module	1.8
Number of starts	1
Lead angle	2° 34'
Pressure angle	20°

Backdriving

- Static self-locking
- No back-driving
- Low dynamic back-driving

M RS 110 PC 100 90 B14 AC 42 MT 1.1 kW 90 S4 B14 X3 B3