

### Input data

|                       |       |            |
|-----------------------|-------|------------|
| System of measurement |       | Metric     |
| Input type            |       | Gear motor |
| Input speed           | [rpm] | 1400       |
| Output speed          | [rpm] | 50         |
| Ratio (i=)            |       | 28         |
| Frequency             | [Hz]  | 50         |
| Input options         |       | IEC        |
| Requested input power | [kW]  | 5.5        |
| Service factor        |       | 1.4        |
| Rated Power P1        | [kW]  | 7.48       |

### Output data

**Gear unit** **M RS 130 PC 28 132 B14 AC 48 MT 5.5 kW 132 S4 B14 X3 B3**

|                     |                     |                          |
|---------------------|---------------------|--------------------------|
| Type                |                     | RS - Worm speed reducers |
| Input type          |                     | M                        |
| Size                |                     | 130                      |
| Ratio (i=)          |                     | 28                       |
| Input flange        |                     | B14                      |
| Mounting position   |                     | B3                       |
| Input speed         | [rpm]               | 1400                     |
| Output speed        | [rpm]               | 50                       |
| Rated output torque | [Nm]                | 808.89                   |
| Service Factor      |                     | 1.4                      |
| Efficiency          |                     | 0.77                     |
| Inertia moment      | [kgm <sup>2</sup> ] | 0.002727                 |

#### Gear unit configuration

|              |  |                     |
|--------------|--|---------------------|
| Output shaft |  | Hollow output shaft |
| Fixing       |  | Shaft mounting      |
| Version      |  | PC                  |

#### Output radial and axial loads

|                                   |     |      |
|-----------------------------------|-----|------|
| Ball bearings output radial load  | [N] | 6600 |
| Taper bearings output radial load | [N] | 9900 |
| Ball bearings output axial load   | [N] | 1320 |
| Taper bearings output axial load  | [N] | 1980 |

#### Accessories

|                     |  |       |
|---------------------|--|-------|
| Hollow output shaft |  | AC 48 |
|---------------------|--|-------|

#### Electric motor

|       |      |        |
|-------|------|--------|
| Size  |      | 132 S4 |
| Poles |      | 4      |
| Power | [kW] | 5.5    |

#### Electric motor configuration

|                       |  |     |
|-----------------------|--|-----|
| Motor flange          |  | B14 |
| Terminal box position |  | X3  |

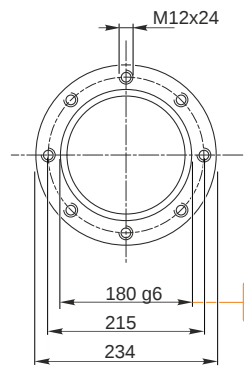
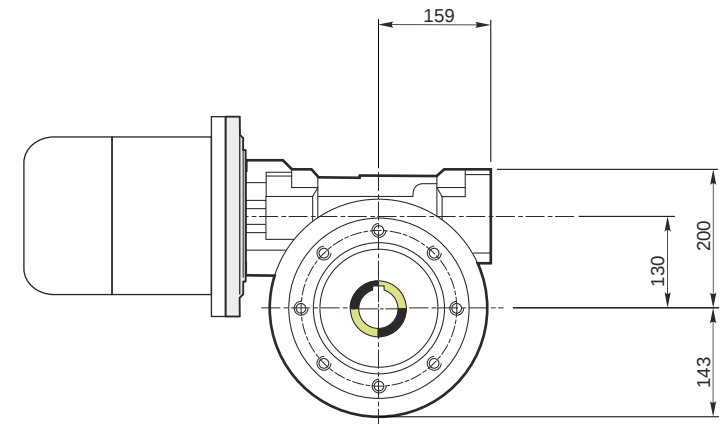
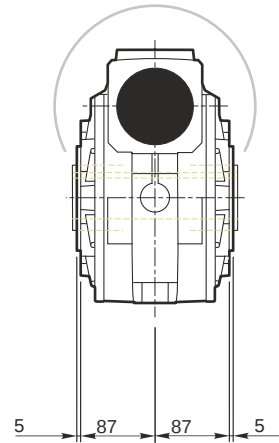
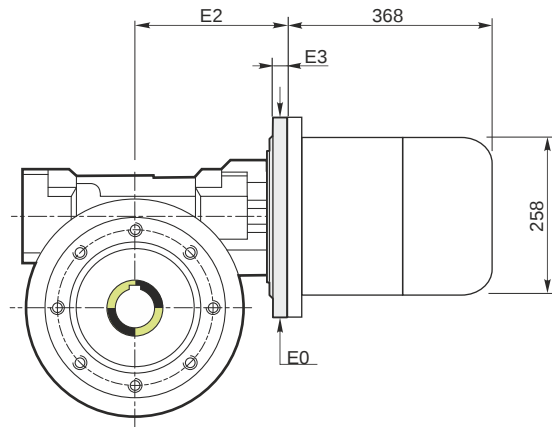

Hollow output shaft

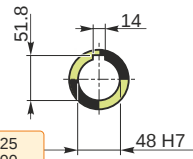

179.986  
179.961

48.025  
48.000

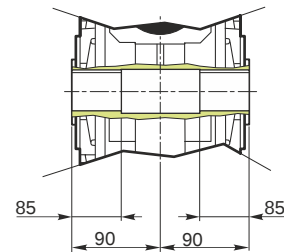

**M RS 130 PC 28 132 B14 AC 48 MT 5.5 kW 132 S4 B14 X3 B3**

**Mounting positions**

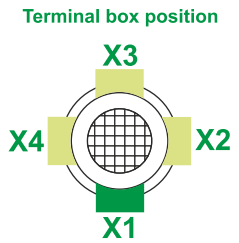
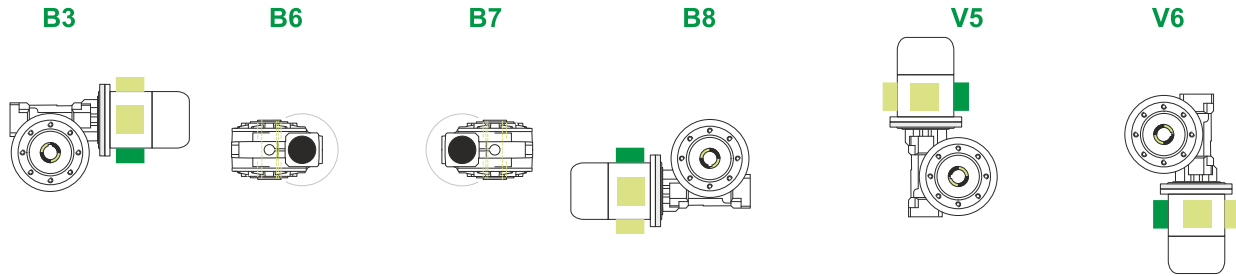

2.75



← Oil quantity [litres]

Lubricant type: Long life synthetic oil ISO VG320

**Direction of rotation**

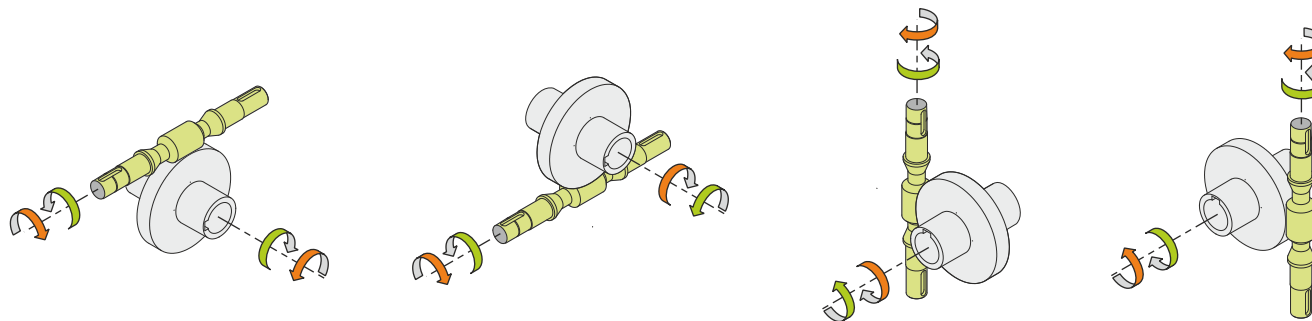

**Weight**

|                     |    |
|---------------------|----|
| Gear unit [kg]      | 50 |
| Electric motor [kg] | 43 |

**Gearing data**

|                  |        |
|------------------|--------|
| Axial module     | 7.25   |
| Number of starts | 1      |
| Lead angle       | 7° 14' |
| Pressure angle   | 20°    |

**Backdriving**

Static self-locking  
Slow back-driving in case of vibrations  
Low dynamic back-driving

**M RS 130 PC 28 132 B14 AC 48 MT 5.5 kW 132 S4 B14 X3 B3**