

Input data

System of measurement		Metric
Input type		Gear motor
Input speed	[rpm]	1400
Output speed	[rpm]	20
Ratio (i=)		70
Frequency	[Hz]	50
Input options		IEC
Requested input power	[kW]	2.2
Service factor		1.2
Rated Power P1	[kW]	2.7

Output data

Gear unit M RS 130 PC 70 100 B14 AC 48 MT 2.2 kW 100 A4 B14 X3 B3

Type		RS - Worm speed reducers
Input type		M
Size		130
Ratio (i=)		70
Input flange		B14
Mounting position		B3
Input speed	[rpm]	1400
Output speed	[rpm]	20
Rated output torque	[Nm]	703.84
Service Factor		1.2
Efficiency		0.67
Inertia moment	[kgm ²]	0.002659

Gear unit configuration

Output shaft		Hollow output shaft
Fixing		Shaft mounting
Version		PC

Output radial and axial loads

Ball bearings output radial load	[N]	9700
Taper bearings output radial load	[N]	14500
Ball bearings output axial load	[N]	1940
Taper bearings output axial load	[N]	2900

Accessories

Hollow output shaft		AC 48
---------------------	--	-------

Electric motor

Size		100 A4
Poles		4
Power	[kW]	2.2

Electric motor configuration

Motor flange		B14
Terminal box position		X3

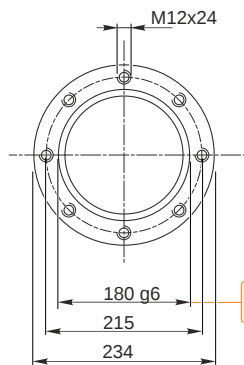
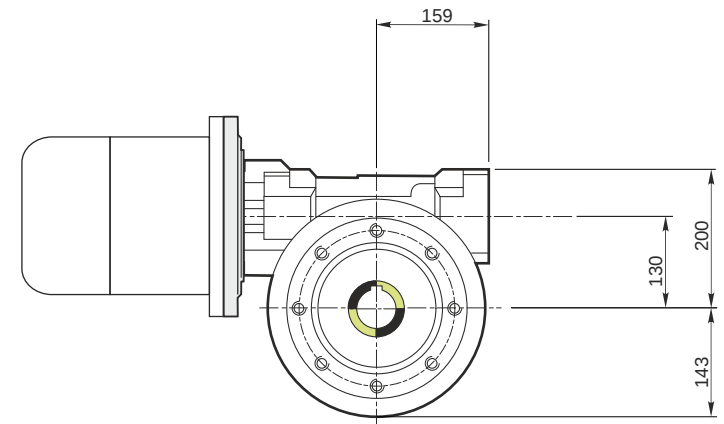
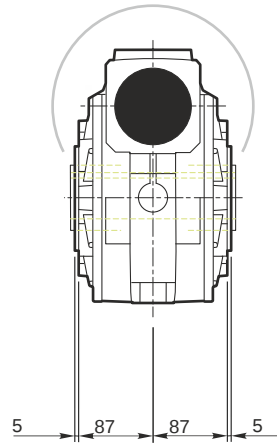
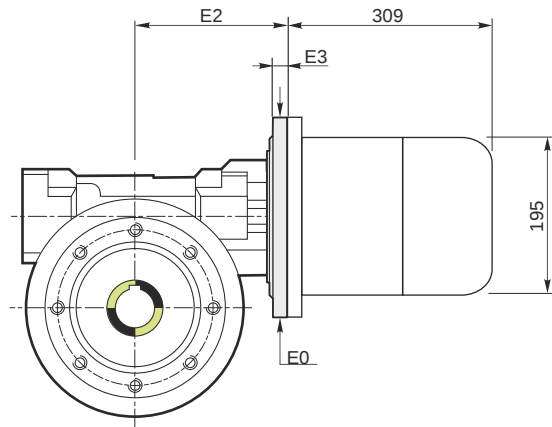

Hollow output shaft

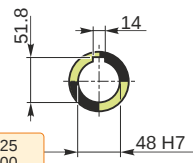

179.986
179.961

48.025
48.000

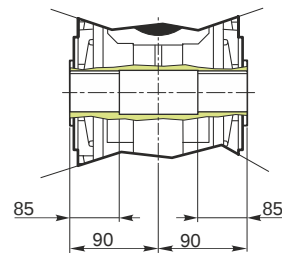

M RS 130 PC 70 100 B14 AC 48 MT 2.2 kW 100 A4 B14 X3 B3

Mounting positions

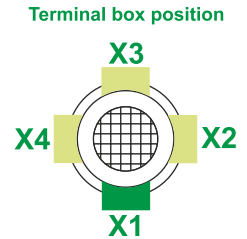
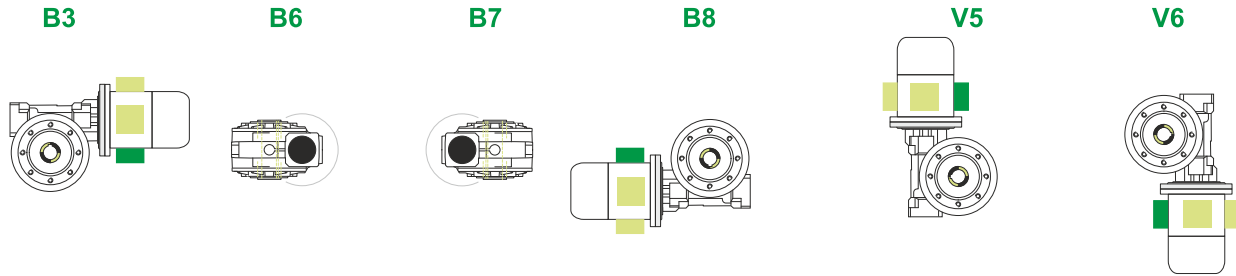

2.75



← Oil quantity [litres]

Lubricant type: Long life synthetic oil ISO VG320

Direction of rotation



Weight

Gear unit [kg]	50
Electric motor [kg]	21

Gearing data

Axial module	3.15
Number of starts	1
Lead angle	4° 33'
Pressure angle	20°

Backdriving

Static self-locking
Slow back-driving in case of vibrations
Low dynamic back-driving

M RS 130 PC 70 100 B14 AC 48 MT 2.2 kW 100 A4 B14 X3 B3