

Input data

System of measurement		Metric
Input type		Gear motor
Input speed	[rpm]	1400
Output speed	[rpm]	35
Ratio (i=)		40
Frequency	[Hz]	50
Input options		IEC
Requested input power	[kW]	7.5
Service factor		1.1
Rated Power P1	[kW]	8

Output data

Gear unit **M RS 150 PC 40 132 B14 AC 55 MT 7.5 kW 132 M4 B14 X3 B3**

Type		RS - Worm speed reducers
Input type		M
Size		150
Ratio (i=)		40
Input flange		B14
Mounting position		B3
Input speed	[rpm]	1400
Output speed	[rpm]	35
Rated output torque	[Nm]	1575.75
Service Factor		1.1
Efficiency		0.77
Inertia moment	[kgm ²]	0.005868

Gear unit configuration

Output shaft		Hollow output shaft
Fixing		Shaft mounting
Version		PC

Output radial and axial loads

Ball bearings output radial load	[N]	11000
Taper bearings output radial load	[N]	16500
Ball bearings output axial load	[N]	2200
Taper bearings output axial load	[N]	3300

Accessories

Hollow output shaft		AC 55
---------------------	--	-------

Electric motor

Size		132 M4
Poles		4
Power	[kW]	7.5

Electric motor configuration

Motor flange		B14
Terminal box position		X3

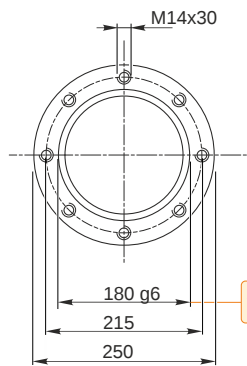
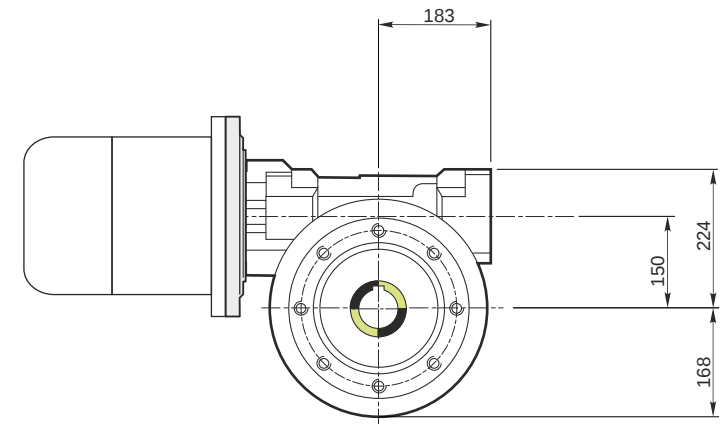
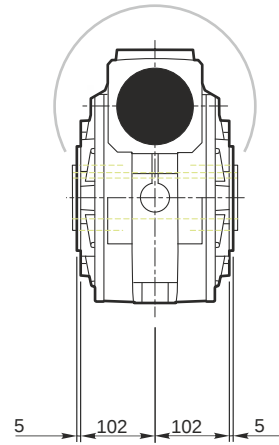
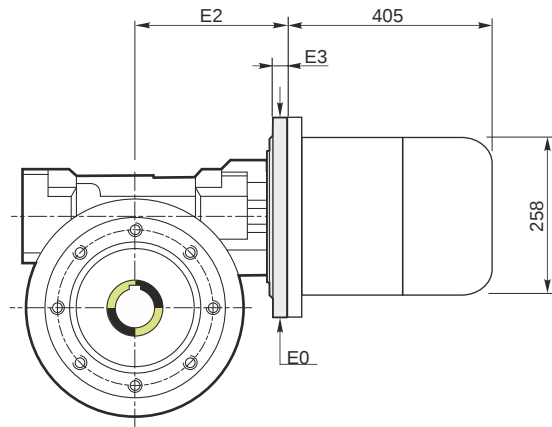

Hollow output shaft

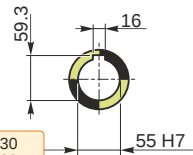

179.986
179.961

55.030
55.000

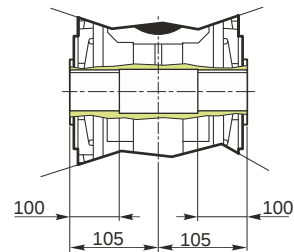

M RS 150 PC 40 132 B14 AC 55 MT 7.5 kW 132 M4 B14 X3 B3

Mounting positions

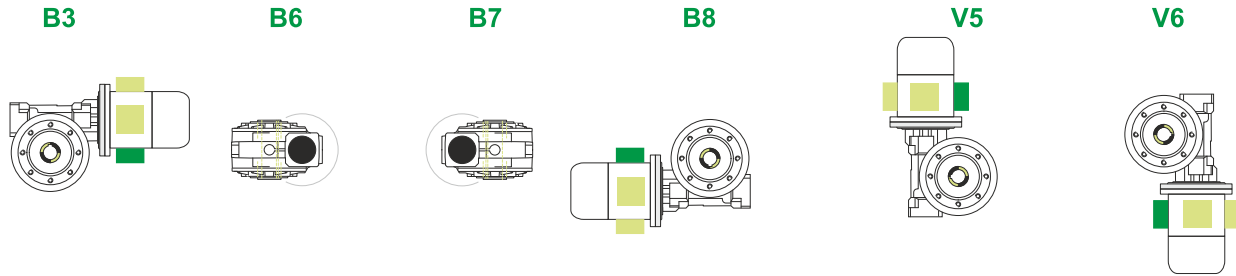

Terminal box position

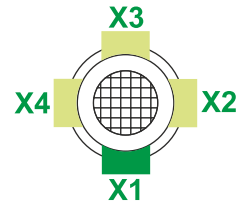

4.4



← Oil quantity [litres]

Lubricant type: Long life synthetic oil ISO VG320

Direction of rotation

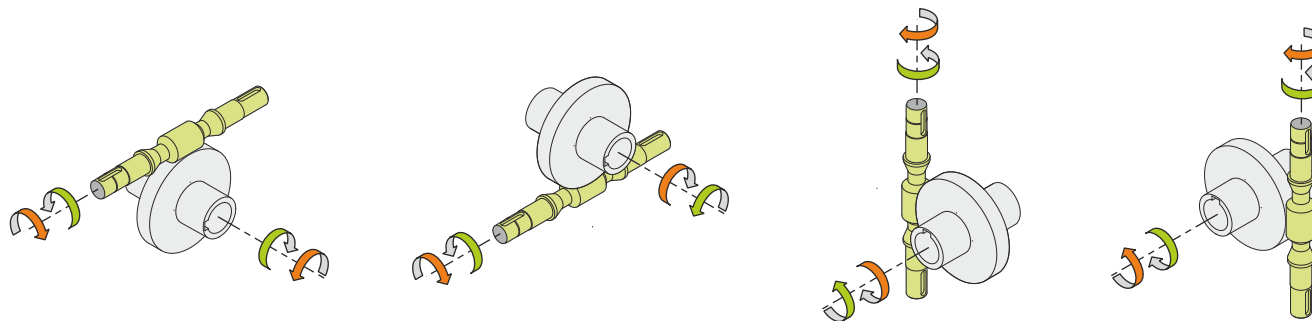

Weight

Gear unit [kg]	80
Electric motor [kg]	52

Gearing data

Axial module	6.25
Number of starts	1
Lead angle	7° 07'
Pressure angle	20°

Backdriving

Static self-locking
Slow back-driving in case of vibrations
Low dynamic back-driving