

### Input data

System of measurement		Metric
Input type		Gear motor
Input speed	[rpm]	1400
Output speed	[rpm]	20
Ratio (i=)		70
Frequency	[Hz]	50
Input options		IEC
Requested input power	[kW]	3
Service factor		1.3
Rated Power P1	[kW]	3.79

### Output data

**Gear unit** **M RS 150 PC 70 100 B14 AC 55 MT 3 kW 100 B4 B14 X3 B3**

Type		RS - Worm speed reducers
Input type		M
Size		150
Ratio (i=)		70
Input flange		B14
Mounting position		B3
Input speed	[rpm]	1400
Output speed	[rpm]	20
Rated output torque	[Nm]	974.1
Service Factor		1.3
Efficiency		0.68
Inertia moment	[kgm <sup>2</sup> ]	0.005819

#### Gear unit configuration

Output shaft		Hollow output shaft
Fixing		Shaft mounting
Version		PC

#### Output radial and axial loads

Ball bearings output radial load	[N]	13000
Taper bearings output radial load	[N]	19500
Ball bearings output axial load	[N]	2600
Taper bearings output axial load	[N]	3900

#### Accessories

Hollow output shaft		AC 55
---------------------	--	-------

### Electric motor

Size		100 B4
Poles		4
Power	[kW]	3

#### Electric motor configuration

Motor flange		B14
Terminal box position		X3

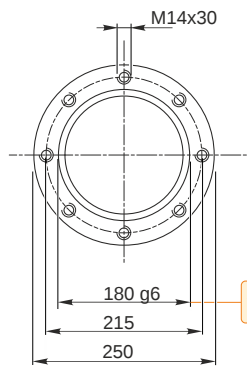
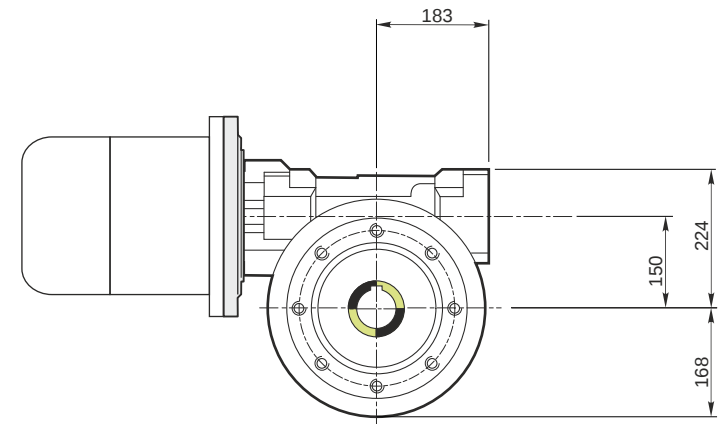
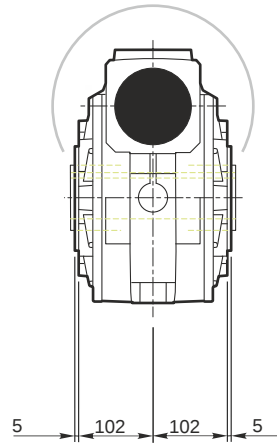
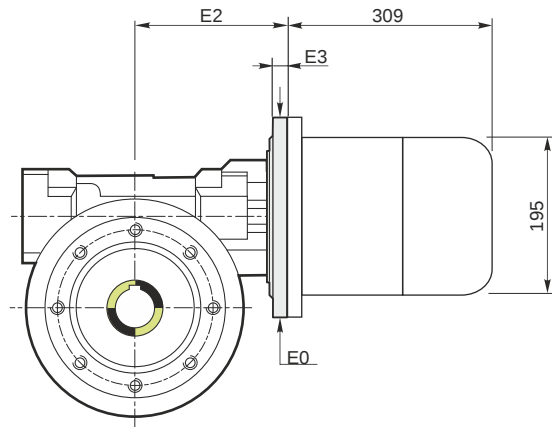

Hollow output shaft

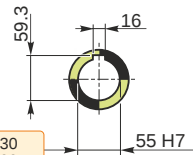

179.986  
179.961

55.030  
55.000

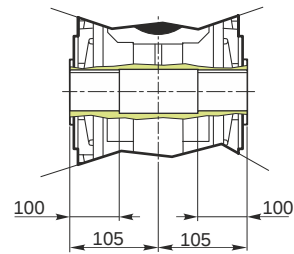

**M RS 150 PC 70 100 B14 AC 55 MT 3 kW 100 B4 B14 X3 B3**

**Mounting positions**

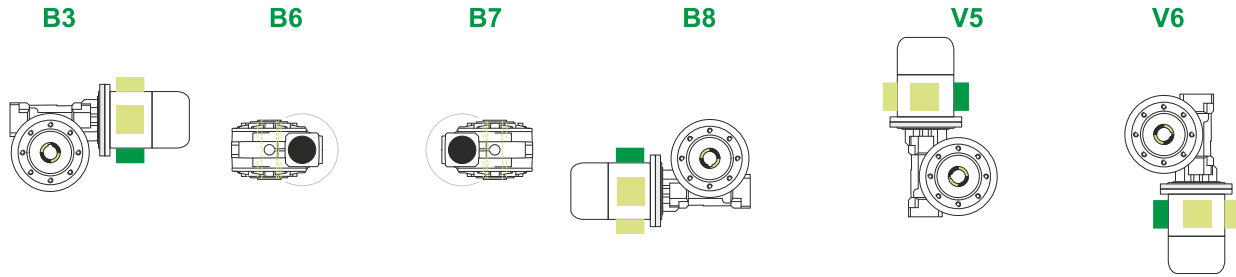

Terminal box position

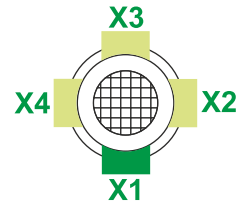

4.4



← Oil quantity [litres]

Lubricant type: Long life synthetic oil ISO VG320

**Direction of rotation**

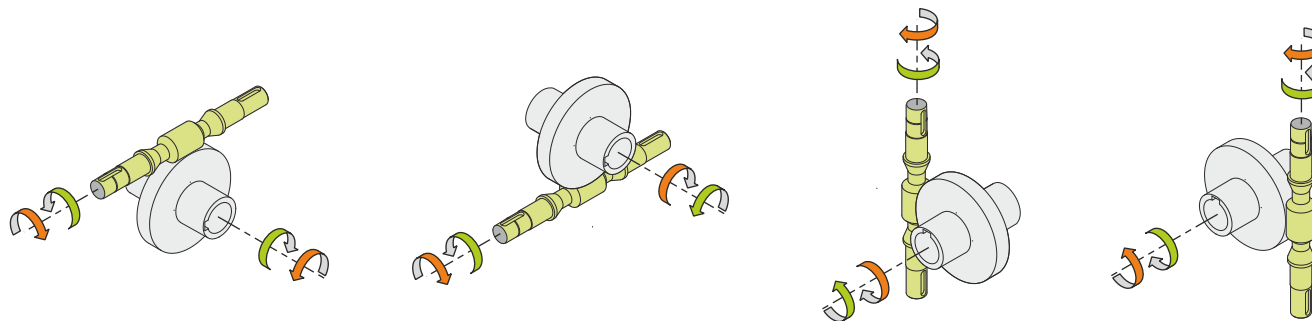

**Weight**

Gear unit [kg]	80
Electric motor [kg]	21

**Gearing data**

Axial module	3.60
Number of starts	1
Lead angle	4° 17'
Pressure angle	20°

**Backdriving**

Static self-locking  
Slow back-driving in case of vibrations  
Low dynamic back-driving

**M RS 150 PC 70 100 B14 AC 55 MT 3 kW 100 B4 B14 X3 B3**