

Input data

System of measurement		Metric
Input type		Gear motor
Input speed	[rpm]	1400
Output speed	[rpm]	3.33
Ratio (i=)		420
Frequency	[Hz]	50
Input options		IEC
Requested input power	[kW]	0.06
Service factor		0.5
Rated Power P1	[kW]	0.03

Warning! The torque generated by the selected motor is above the gearbox rated output torque; please refer to the gearbox rated output torque.

Output data

Gear unit	M RT/RT 28/28 B3 21 420 56 B14 AC 14 MT 0.06 kW 56 A4 B14 X3
------------------	---

Type		RT/RT - Worm speed reducers
Input type		M
Size		28/28
Ratio (i=)		420
Gearbox ratio		28.00
Pre-stage ratio		15.00
Input flange		B14
Input speed	[rpm]	1400
Output speed	[rpm]	3.33
Rated output torque	[Nm]	35
Service Factor		0.5
Efficiency		0.38

Gear unit configuration

Output shaft		Hollow output shaft
Fixing		Universal
Version		B3
Attachment position		21

Output radial and axial loads

Ball bearings output radial load	[N]	1000
Taper bearings output radial load	[N]	1300
Ball bearings output axial load	[N]	200
Taper bearings output axial load	[N]	260

Accessories

Hollow output shaft		AC 14
---------------------	--	-------

Electric motor

Size		56 A4
Poles		4
Power	[kW]	0.06

Electric motor configuration

Motor flange		B14
Terminal box position		X3

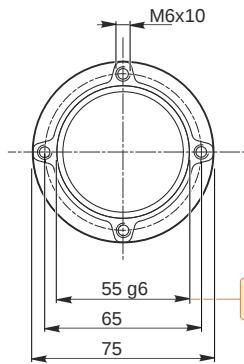
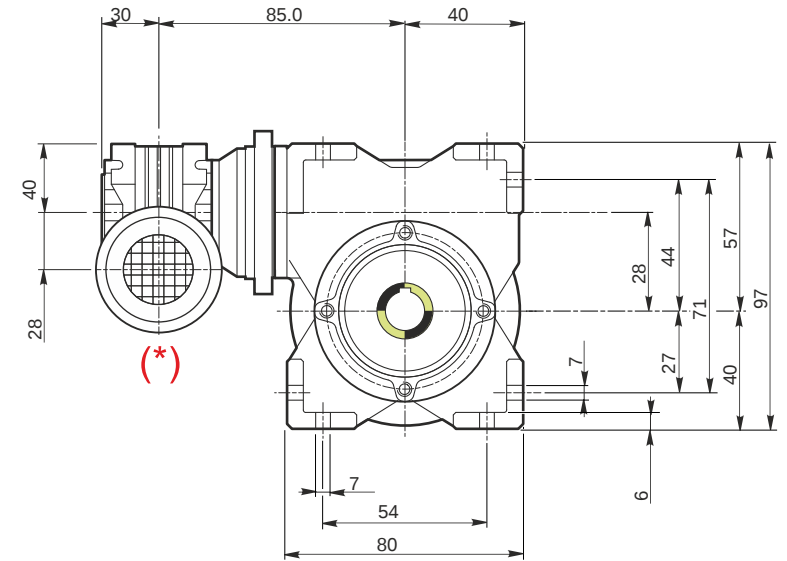
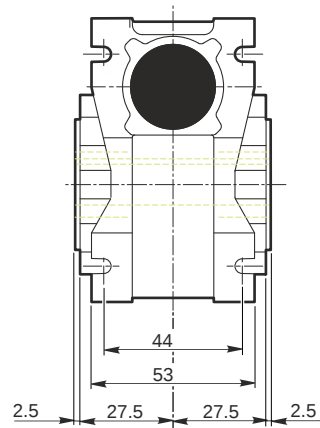
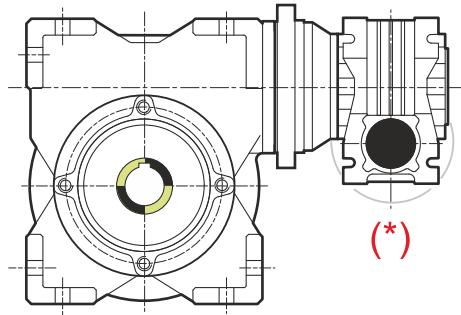

54.990
54.971

Hollow output shaft

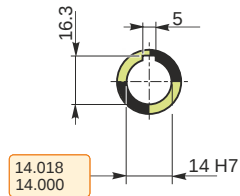

14.018
14.000

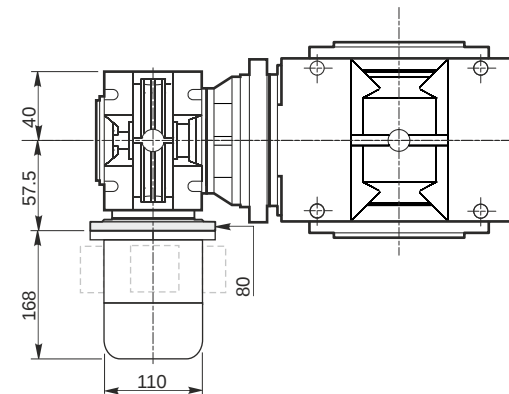
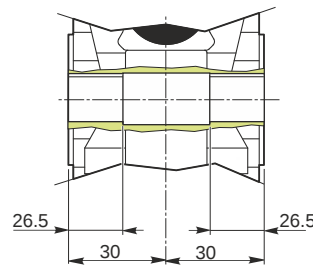

Mounting positions

B3

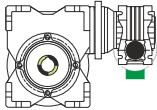

B6

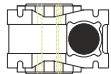

B7

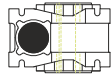

B8

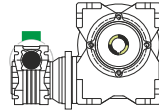

V5

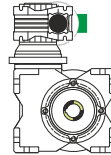

V6

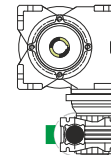

Terminal box position

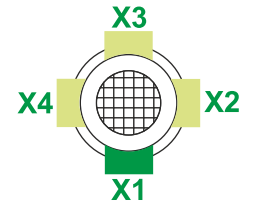

0.03	1	2	1	← Oil quantity [litres]
0.03	2	1	2	

Lubricant type: Long life synthetic oil ISO VG320

Attachment position

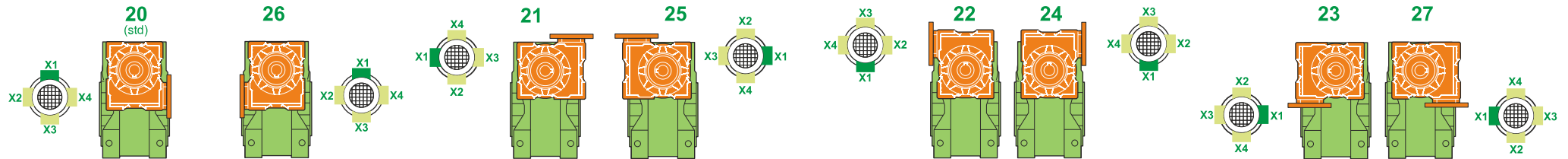

Direction of rotation

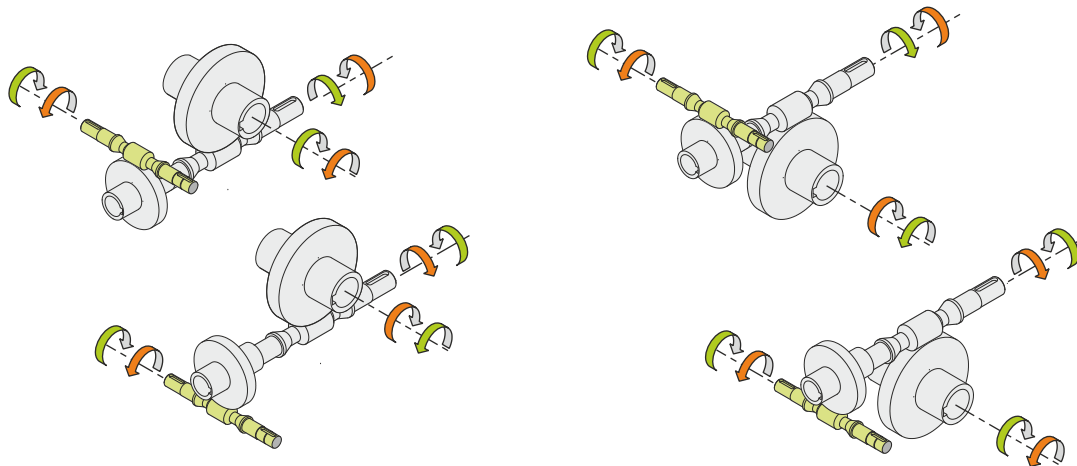

Weight

Gear unit [kg]	2.5
Electric motor [kg]	2.6

Gearing data

	Axial module	1.5
	Number of starts	1
	Lead angle	6° 06'
	Pressure angle	20°

Backdriving

Static self-locking
Slow back-driving in case of vibrations
Low dynamic back-driving

M RT/RT 28/28 B3 21 420 56 B14 AC 14 MT 0.06 kW 56 A4 B14 X3