

### Input data

System of measurement		Metric
Input type		Gear motor
Input speed	[rpm]	1400
Output speed	[rpm]	0.89
Ratio (i=)		1568
Frequency	[Hz]	50
Input options		IEC
Requested input power	[kW]	0.06
Service factor		0.5
Rated Power P1	[kW]	0.03

**Warning! The torque generated by the selected motor is above the gearbox rated output torque; please refer to the gearbox rated output torque.**

### Output data

<b>Gear unit</b>	<b>M RT/RT 28/60 B3 21 1568 56 B14 AC 25 MT 0.06 kW 56 A4 B14 X3</b>
------------------	--

Type		RT/RT - Worm speed reducers
Input type		M
Size		28/60
Ratio (i=)		1568
Gearbox ratio		28.00
Pre-stage ratio		56.00
Input flange		B14
Input speed	[rpm]	1400
Output speed	[rpm]	0.89
Rated output torque	[Nm]	91
Service Factor		0.5
Efficiency		0.27

#### Gear unit configuration

Output shaft		Hollow output shaft
Fixing		Universal
Version		B3
Attachment position		21

#### Output radial and axial loads

Ball bearings output radial load	[N]	5600
Taper bearings output radial load	[N]	6600
Ball bearings output axial load	[N]	1120
Taper bearings output axial load	[N]	1320

#### Accessories

Hollow output shaft		AC 25
---------------------	--	-------

#### Electric motor

Size		56 A4
Poles		4
Power	[kW]	0.06

#### Electric motor configuration

Motor flange		B14
Terminal box position		X3

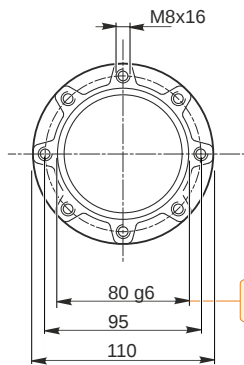
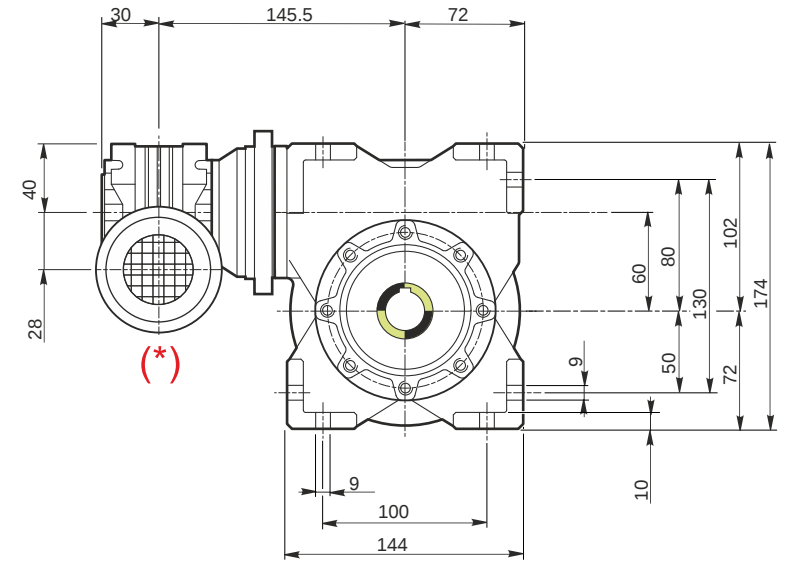
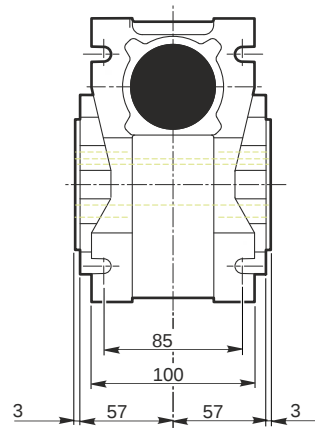
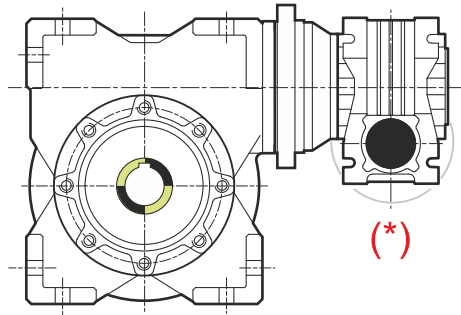

79.990  
79.971

*Hollow output shaft*

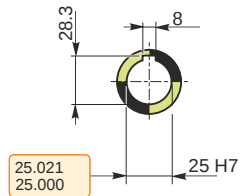

25.021  
25.000

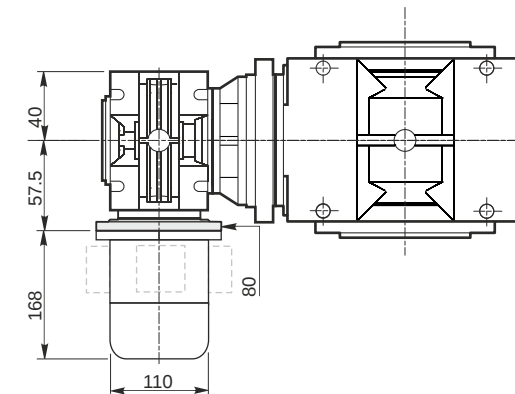
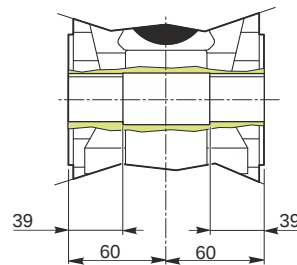

**Mounting positions**

**B3**

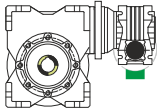

**B6**

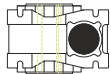

**B7**

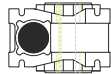

**B8**

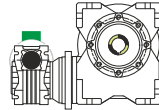

**V5**

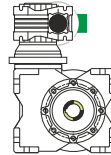

**V6**

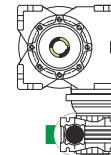

Terminal box position

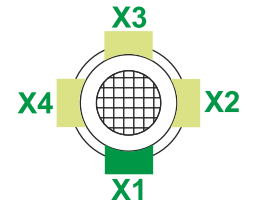

0.03	1	2	1	← Oil quantity [litres]
0.23	2	1	2	

Lubricant type: Long life synthetic oil ISO VG320

**Attachment position**

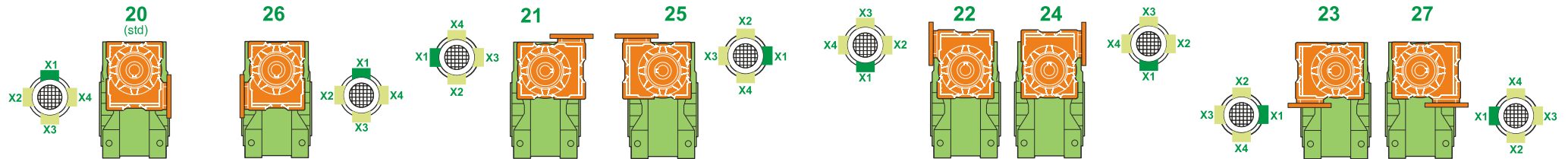

**Direction of rotation**

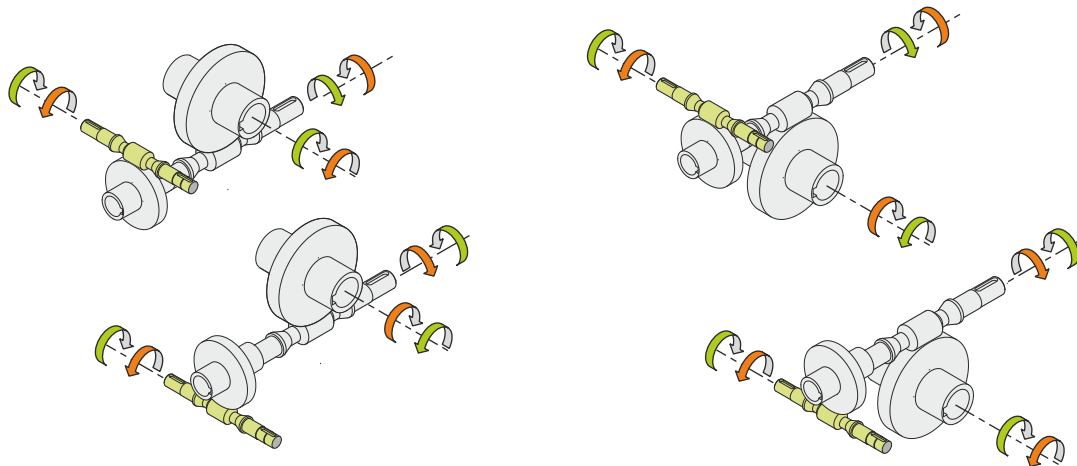

**Weight**

Gear unit [kg]	7.9
Electric motor [kg]	2.6

**Gearing data**

	Axial module	3.3
	Number of starts	1
	Lead angle	6° 49'
	Pressure angle	20°

**Backdriving**

Static self-locking  
Slow back-driving in case of vibrations  
Low dynamic back-driving

**M RT/RT 28/60 B3 21 1568 56 B14 AC 25 MT 0.06 kW 56 A4 B14 X3**