

### Input data

System of measurement		Metric
Input type		Gear motor
Input speed	[rpm]	1400
Output speed	[rpm]	0.25
Ratio (i=)		5600
Frequency	[Hz]	50
Input options		IEC
Requested input power	[kW]	0.06
Service factor		0.7
Rated Power P1	[kW]	0.04

**Warning! The torque generated by the selected motor is above the gearbox rated output torque; please refer to the gearbox rated output torque.**

### Output data

<b>Gear unit</b>	<b>M RT/RT 40/70 B3 21 5600 56 B5 AC 28 MT 0.06 kW 56 A4 B5 X3</b>
------------------	--

Type		RT/RT - Worm speed reducers
Input type		M
Size		40/70
Ratio (i=)		5600
Gearbox ratio		56.00
Pre-stage ratio		100.00
Input flange		B5
Input speed	[rpm]	1400
Output speed	[rpm]	0.25
Rated output torque	[Nm]	321
Service Factor		0.7
Efficiency		0.2

#### Gear unit configuration

Output shaft		Hollow output shaft
Fixing		Universal
Version		B3
Attachment position		21

#### Output radial and axial loads

Ball bearings output radial load	[N]	6700
Taper bearings output radial load	[N]	7900
Ball bearings output axial load	[N]	1340
Taper bearings output axial load	[N]	1580

#### Accessories

Hollow output shaft		AC 28
---------------------	--	-------

#### Electric motor

Size		56 A4
Poles		4
Power	[kW]	0.06

#### Electric motor configuration

Motor flange		B5
Terminal box position		X3

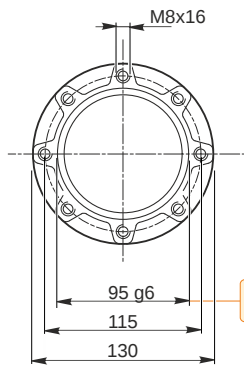
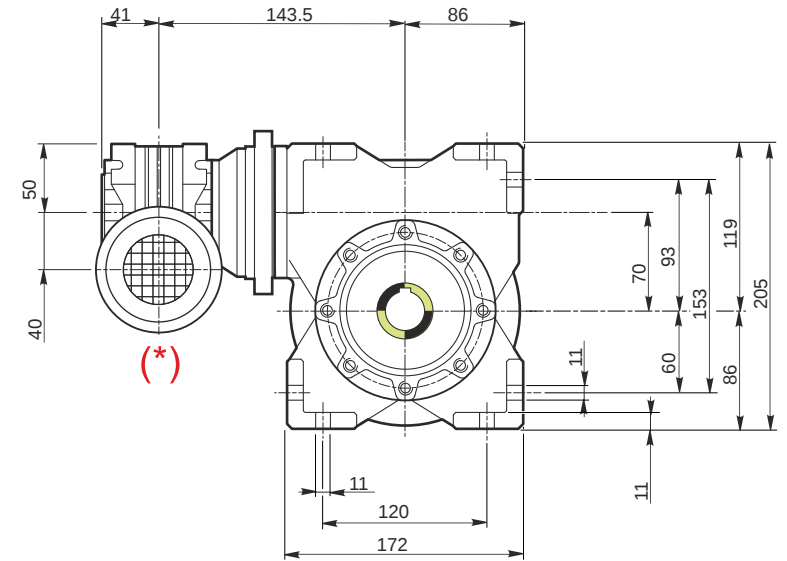
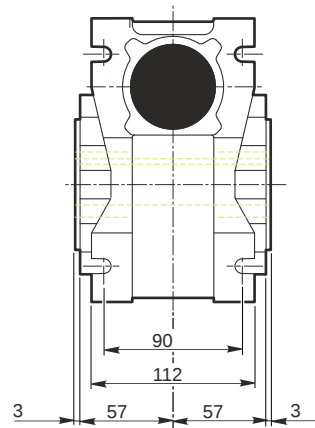
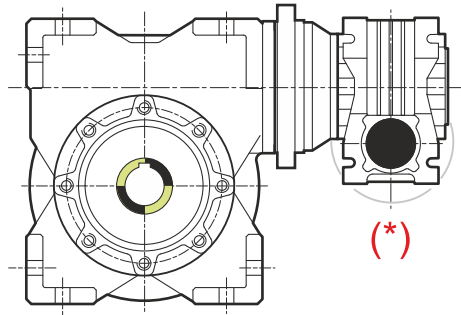

94.988  
94.966

*Hollow output shaft*

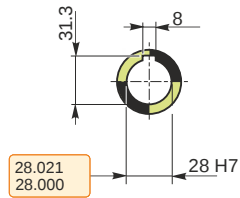

28.021  
28.000

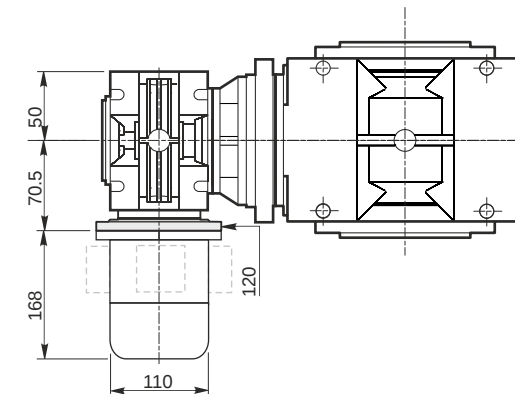
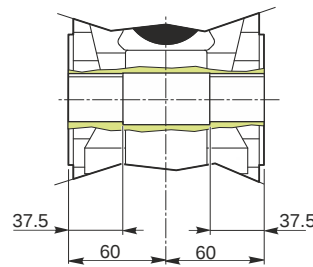

**Mounting positions**

**B3**

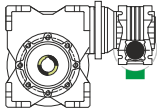

**B6**

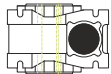

**B7**

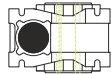

**B8**

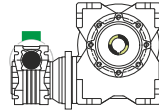

**V5**

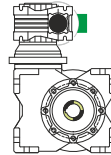

**V6**

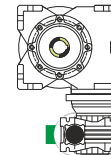

Terminal box position

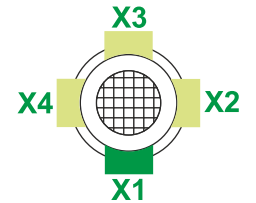

0.08	1	2	1	← Oil quantity [litres]
0.35	2	2	1	

Lubricant type: Long life synthetic oil ISO VG320

**Attachment position**

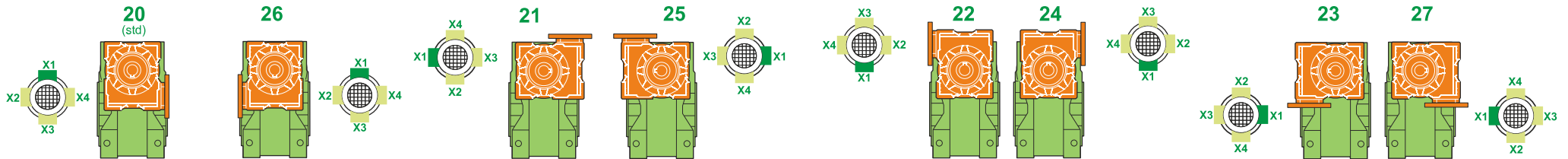

**Direction of rotation**

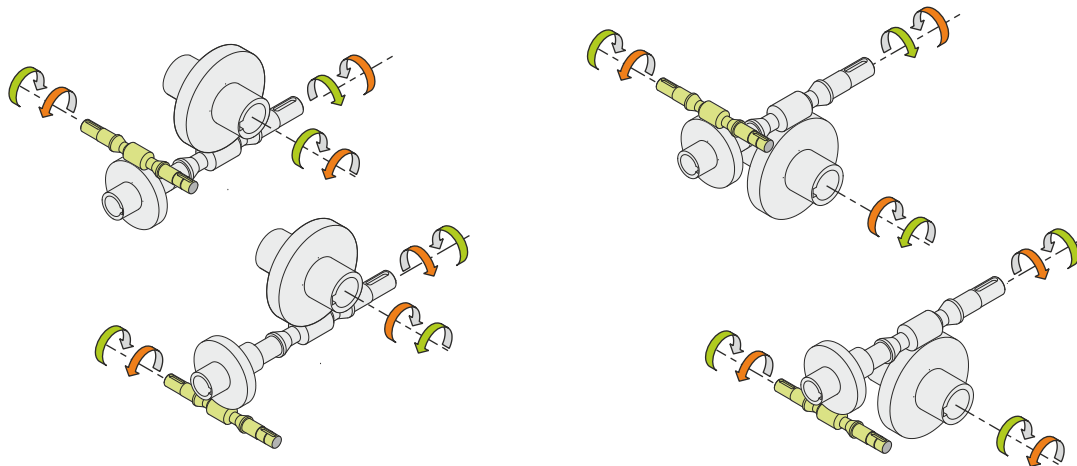

**Weight**

Gear unit [kg]	12
Electric motor [kg]	2.6

**Gearing data**

	Axial module	2
	Number of starts	1
	Lead angle	4° 05'
	Pressure angle	20°

**Backdriving**

- Static self-locking
- No back-driving
- No dynamic back-driving

**M RT/RT 40/70 B3 21 5600 56 B5 AC 28 MT 0.06 kW 56 A4 B5 X3**