

Input data

System of measurement		Metric
Input type		Gear motor
Input speed	[rpm]	1400
Output speed	[rpm]	0.25
Ratio (i=)		5600
Frequency	[Hz]	50
Input options		IEC
Requested input power	[kW]	0.13
Service factor		1
Rated Power P1	[kW]	0.13

Output data

Gear unit	M RT/RT 50/110 B3 21 5600 63 B5 AC 42 MT 0.13 kW 63 A4 B5 X3
------------------	---

Type		RT/RT - Worm speed reducers
Input type		M
Size		50/110
Ratio (i=)		5600
Gearbox ratio		56.00
Pre-stage ratio		100.00
Input flange		B5
Input speed	[rpm]	1400
Output speed	[rpm]	0.25
Rated output torque	[Nm]	993.2
Service Factor		1
Efficiency		0.2

Gear unit configuration

Output shaft		Hollow output shaft
Fixing		Universal
Version		B3
Attachment position		21

Output radial and axial loads

Ball bearings output radial load	[N]	9800
Taper bearings output radial load	[N]	11100
Ball bearings output axial load	[N]	1960
Taper bearings output axial load	[N]	2220

Accessories

Hollow output shaft		AC 42
---------------------	--	-------

Electric motor

Size		63 A4
Poles		4
Power	[kW]	0.13

Electric motor configuration

Motor flange		B5
Terminal box position		X3

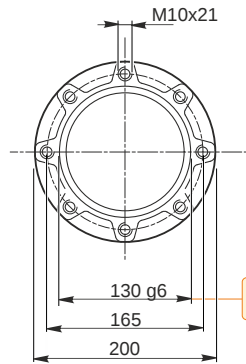
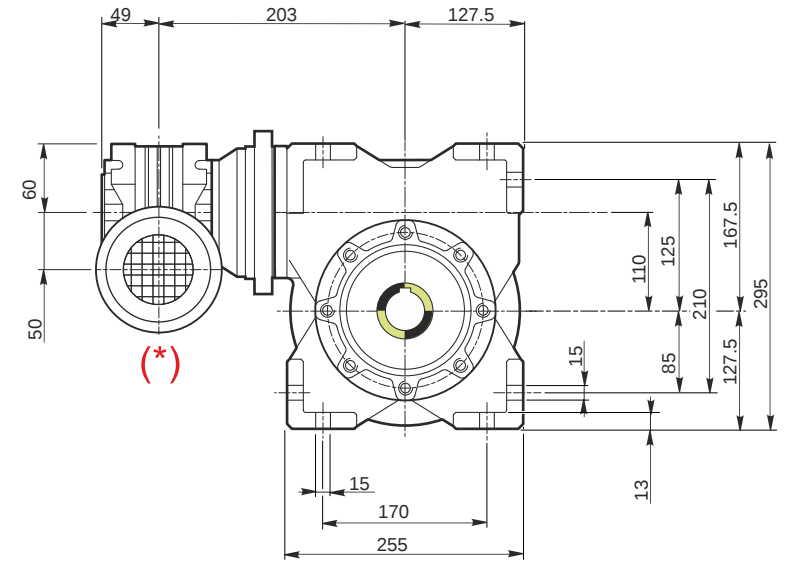
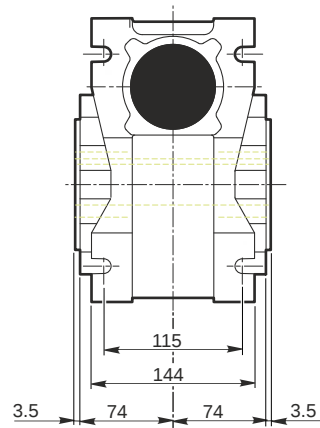
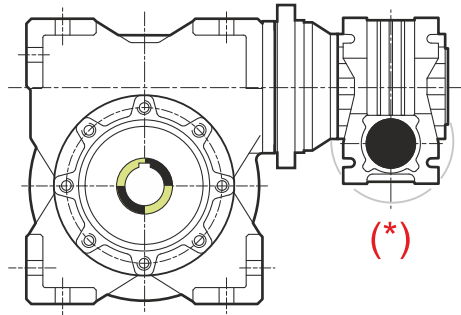

129.986
129.961

Hollow output shaft

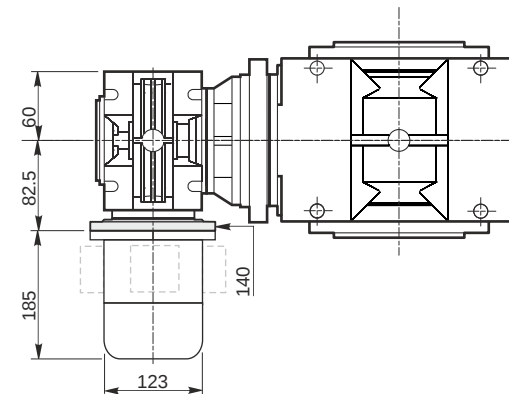
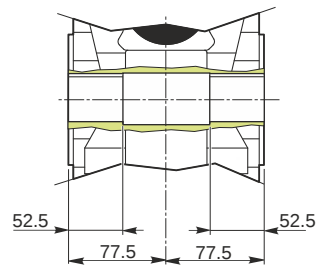
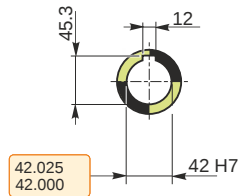

Mounting positions

B3

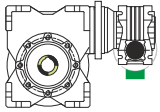

B6

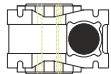

B7

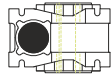

B8

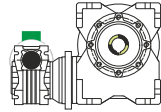

V5

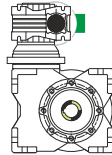

V6

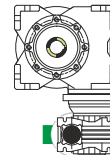

Terminal box position

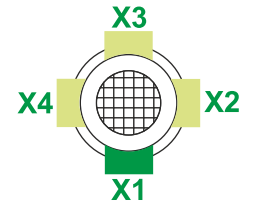

0.13	1	2	1	← Oil quantity [litres]
1.5	2			

Lubricant type: Long life synthetic oil ISO VG320

Attachment position

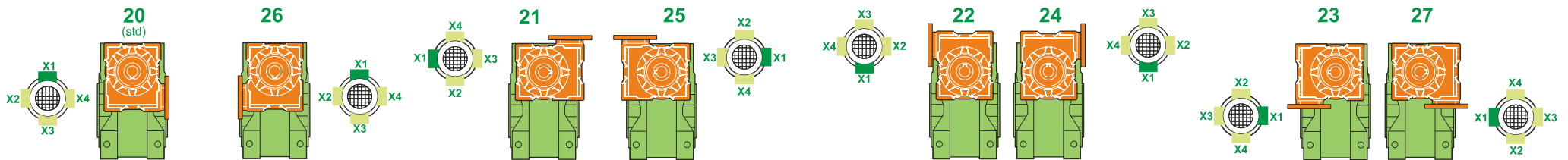

Direction of rotation

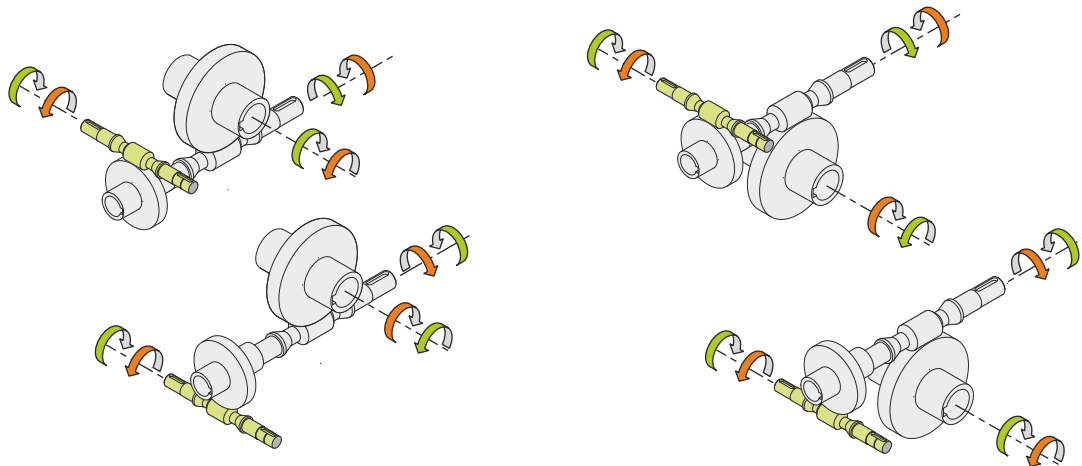

Weight

Gear unit [kg]	45
Electric motor [kg]	4.3

Gearing data

Axial module	3.2
Number of starts	1
Lead angle	4° 29'
Pressure angle	20°

Backdriving

Static self-locking
No back-driving
No dynamic back-driving

M RT/RT 50/110 B3 21 5600 63 B5 AC 42 MT 0.13 kW 63 A4 B5 X3