

Input data

System of measurement		Metric
Input type		Gear motor
Input speed	[rpm]	1400
Output speed	[rpm]	1.25
Ratio (i=)		1120
Frequency	[Hz]	50
Input options		IEC
Requested input power	[kW]	0.18
Service factor		0.9
Rated Power P1	[kW]	0.16

Output data

Gear unit **M RS/RS 40/70 S (bolted) 11 1120 63 B14 AC 28 MT 0.18 kW 63 B4 B14 X3 B3**

Type		RS/RS - Worm speed reducers
Input type		M
Size		40/70
Ratio (i=)		1120
Gearbox ratio		28.00
Pre-stage ratio		40.00
Input flange		B14
Mounting position		B3
Input speed	[rpm]	1400
Output speed	[rpm]	1.25
Rated output torque	[Nm]	453.82
Service Factor		0.9
Efficiency		0.33

Gear unit configuration

Output shaft		Hollow output shaft
Fixing		Feet
Version		S (bolted)
Attachment position		11

Output radial and axial loads

Ball bearings output radial load	[N]	6700
Taper bearings output radial load	[N]	7900
Ball bearings output axial load	[N]	1340
Taper bearings output axial load	[N]	1580

Accessories

Hollow output shaft		AC 28
---------------------	--	-------

Electric motor

Size		63 B4
Poles		4
Power	[kW]	0.18

Electric motor configuration

Motor flange		B14
Terminal box position		X3

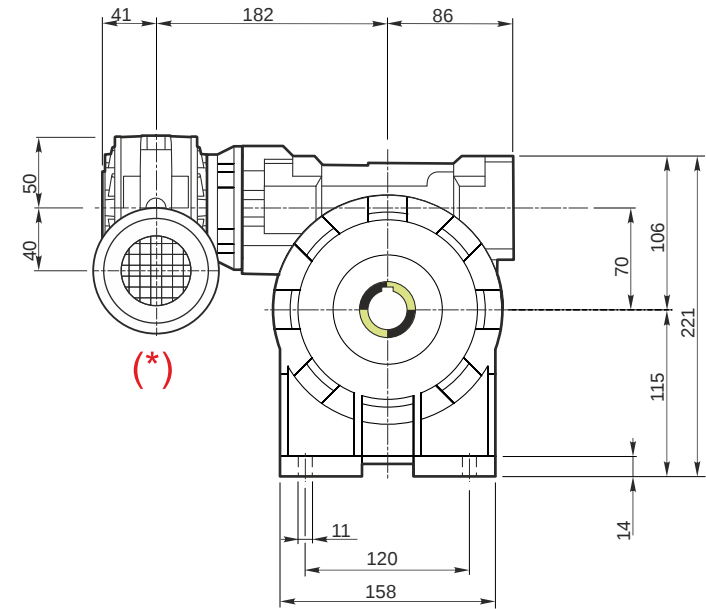
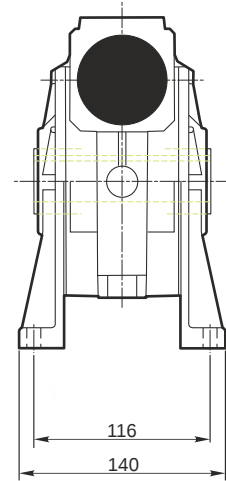

Hollow output shaft

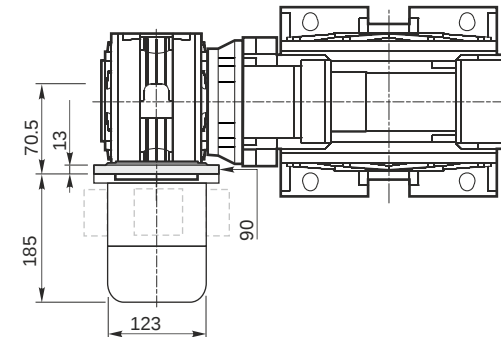
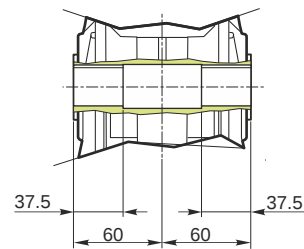
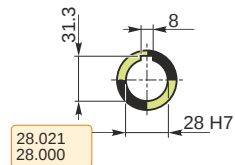

M RS/RS 40/70 S (bolted) 11 1120 63 B14 AC 28 MT 0.18 kW 63 B4 B14 X3 B3

Mounting positions

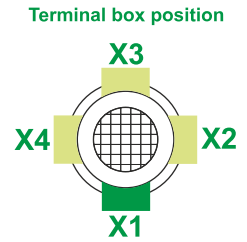
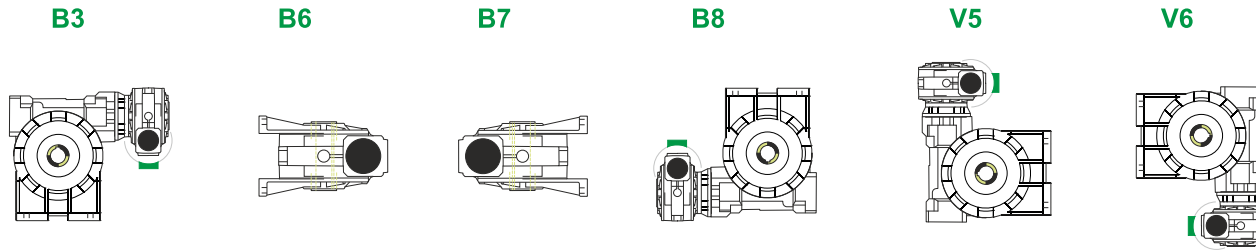

0.08	1
0.35	2



Lubricant type: Long life synthetic oil ISO VG320

Attachment position

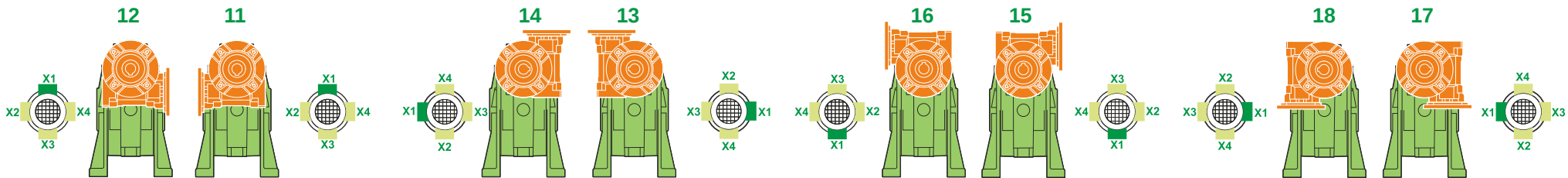

Direction of rotation

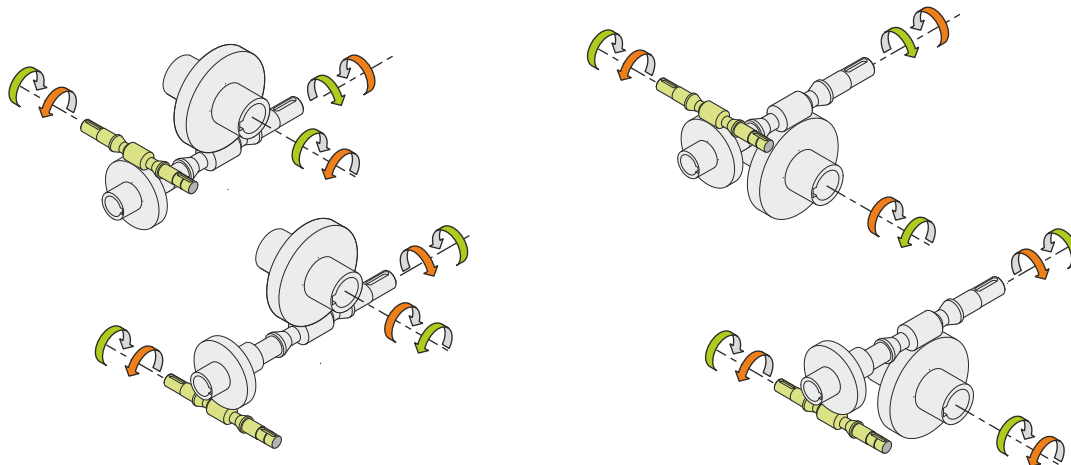

Weight

Gear unit [kg]	12
Electric motor [kg]	4.3

Gearing data 2

	Axial module	3.9
	Number of starts	1
	Lead angle	1
	Pressure angle	20°12'

Backdriving

- Static self-locking
- Slow back-driving in case of vibrations
- Low dynamic back-driving

M RS/RS 40/70 S (bolted) 11 1120 63 B14 AC 28 MT 0.18 kW 63 B4 B14 X3 B3