

### Input data

System of measurement		Metric
Input type		Gear motor
Input speed	[rpm]	1400
Output speed	[rpm]	0.89
Ratio (i=)		1568
Frequency	[Hz]	50
Input options		IEC
Requested input power	[kW]	0.18
Service factor		1
Rated Power P1	[kW]	0.05

### Output data

**Gear unit** **M RS/RS 40/85 S (bolted) 11 1568 63 B14 AC 32 MT 0.18 kW 63 B4 B14 X3 B3**

Type		RS/RS - Worm speed reducers
Input type		M
Size		40/85
Ratio (i=)		1568
Gearbox ratio		28.00
Pre-stage ratio		56.00
Input flange		B14
Mounting position		B3
Input speed	[rpm]	1400
Output speed	[rpm]	0.89
Rated output torque	[Nm]	616.09
Service Factor		1
Efficiency		0.32

#### Gear unit configuration

Output shaft		Hollow output shaft
Fixing		Feet
Version		S (bolted)
Attachment position		11

#### Output radial and axial loads

Ball bearings output radial load	[N]	8300
Taper bearings output radial load	[N]	9400
Ball bearings output axial load	[N]	1660
Taper bearings output axial load	[N]	1880

#### Accessories

Hollow output shaft		AC 32
---------------------	--	-------

#### Electric motor

Size		63 B4
Poles		4
Power	[kW]	0.18

#### Electric motor configuration

Motor flange		B14
Terminal box position		X3

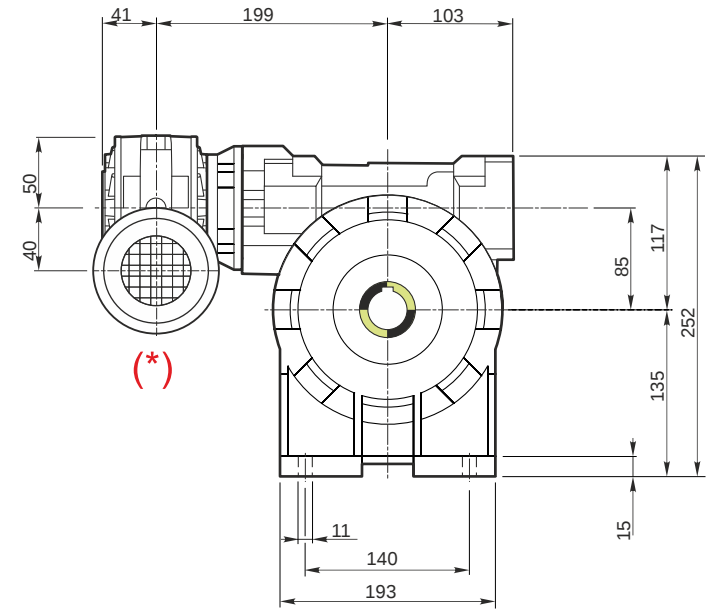
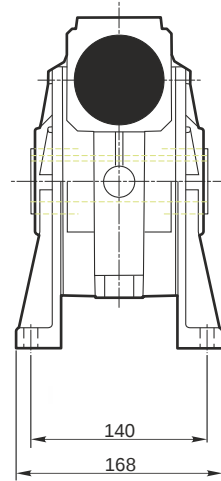
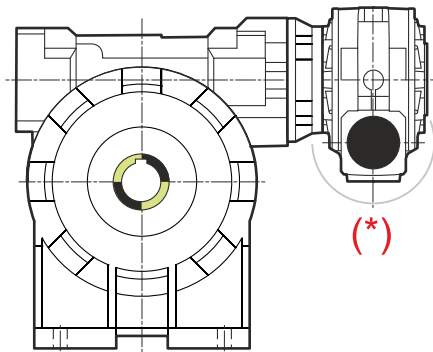

**Hollow output shaft**

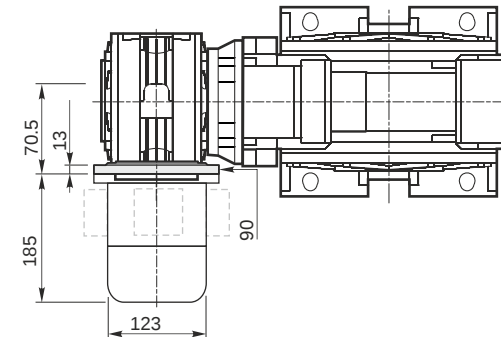
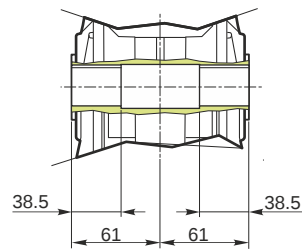
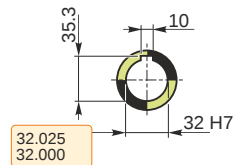

**M RS/RS 40/85 S (bolted) 11 1568 63 B14 AC 32 MT 0.18 kW 63 B4 B14 X3 B3**

**Mounting positions**

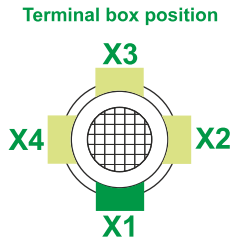
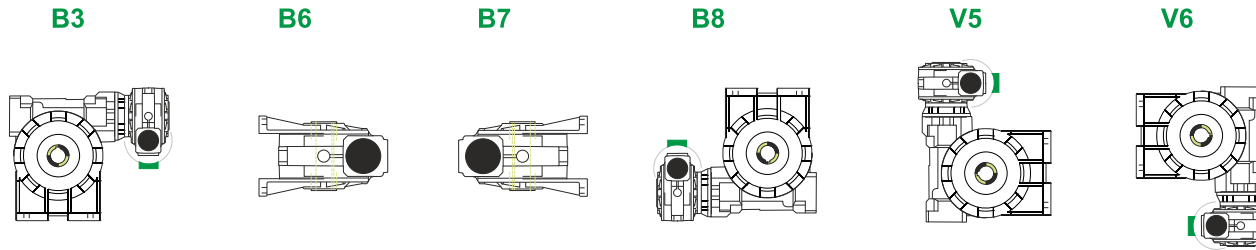

0.08	1
0.6	2

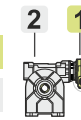

Oil quantity [litres]

Lubricant type: Long life synthetic oil ISO VG320

**Attachment position**

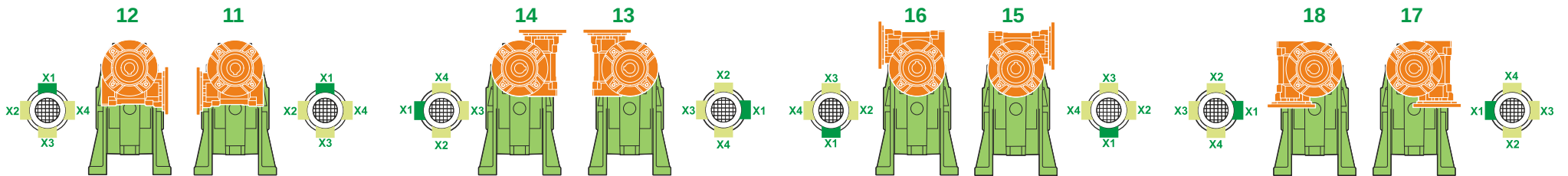

**Direction of rotation**

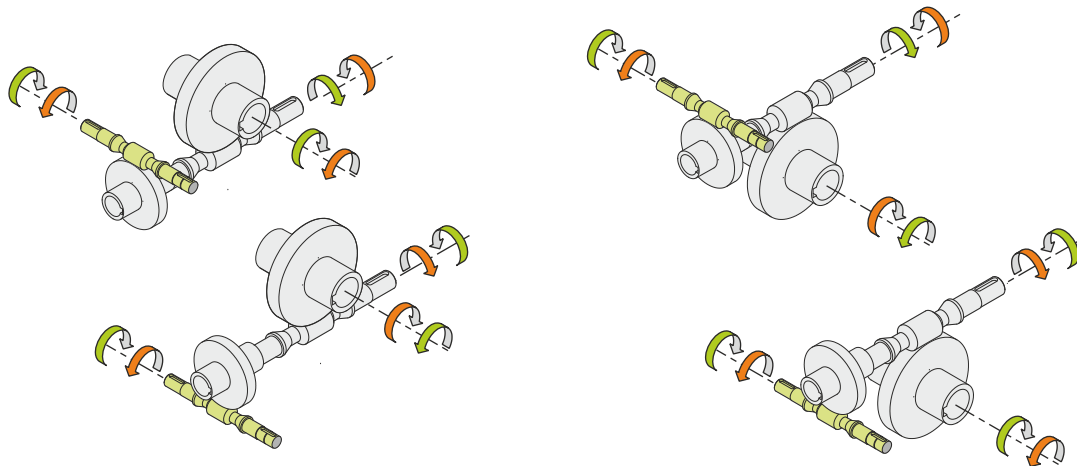

**Weight**

Gear unit [kg]	16.5
Electric motor [kg]	4.3

**Gearing data 2**



Axial module	4.7
Number of starts	1
Lead angle	1
Pressure angle	20° 58'

**Backdriving**

- Static self-locking
- Slow back-driving in case of vibrations
- Low dynamic back-driving

**M RS/RS 40/85 S (bolted) 11 1568 63 B14 AC 32 MT 0.18 kW 63 B4 B14 X3 B3**