

### Input data

System of measurement		Metric
Input type		Gear motor
Input speed	[rpm]	1400
Output speed	[rpm]	3.33
Ratio (i=)		420
Frequency	[Hz]	50
Input options		IEC
Requested input power	[kW]	2.2
Service factor		0.8
Rated Power P1	[kW]	1.73

### Output data

**Gear unit** **M RS/RS 70/150 S (integral) 11 420 100 B14 AC 55 MT 2.2 kW 100 A4 B14 X3 B3**

Type		RS/RS - Worm speed reducers
Input type		M
Size		70/150
Ratio (i=)		420
Gearbox ratio		28.00
Pre-stage ratio		15.00
Input flange		B14
Mounting position		B3
Input speed	[rpm]	1400
Output speed	[rpm]	3.33
Rated output torque	[Nm]	3277.56
Service Factor		0.8
Efficiency		0.52

#### Gear unit configuration

Output shaft		Hollow output shaft
Fixing		Feet
Version		S (integral)
Attachment position		11

#### Output radial and axial loads

Ball bearings output radial load	[N]	15000
Taper bearings output radial load	[N]	19500
Ball bearings output axial load	[N]	3000
Taper bearings output axial load	[N]	3900

#### Accessories

Hollow output shaft		AC 55
---------------------	--	-------

#### Electric motor

Size		100 A4
Poles		4
Power	[kW]	2.2

#### Electric motor configuration

Motor flange		B14
Terminal box position		X3

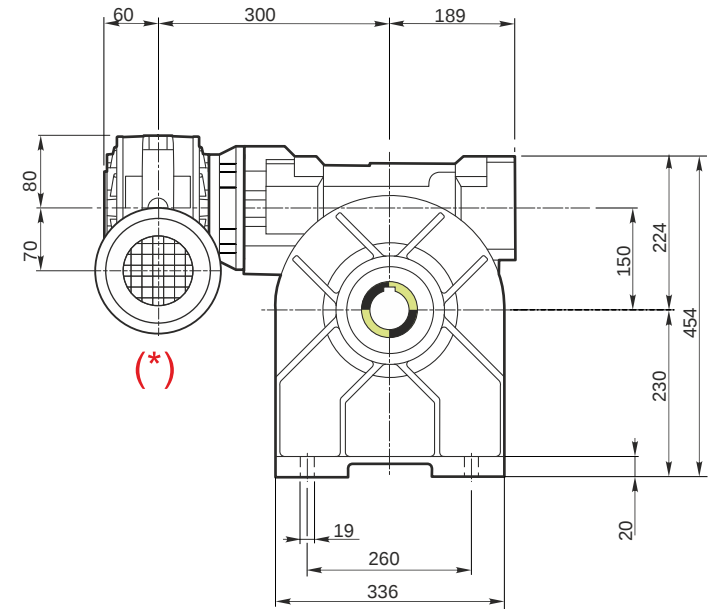
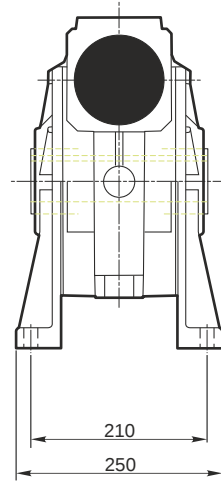
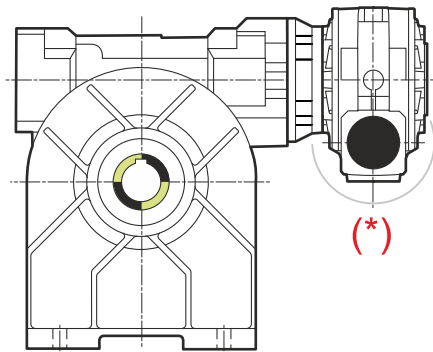

**Hollow output shaft**

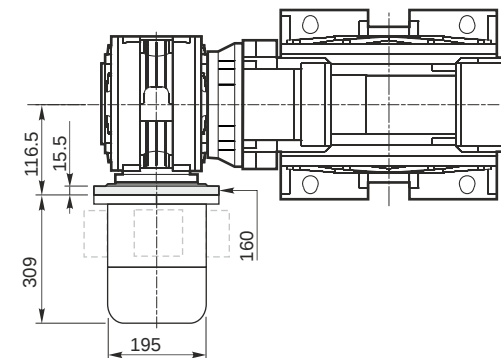
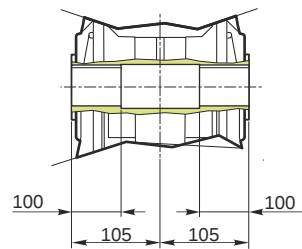
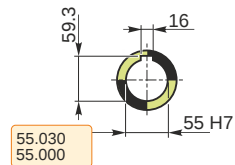

**M RS/RS 70/150 S (integral) 11 420 100 B14 AC 55 MT 2.2 kW 100 A4 B14 X3 B3**

**Mounting positions**

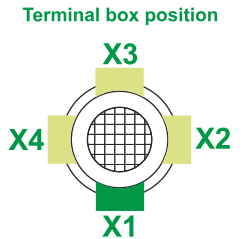
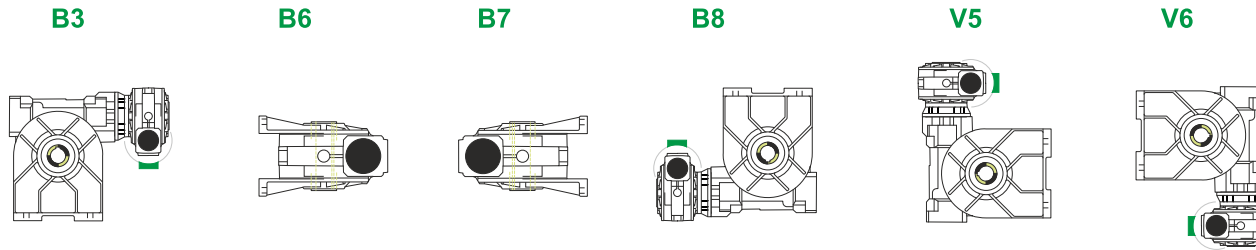

0.35	1
4.4	2



Lubricant type: Long life synthetic oil ISO VG320

**Attachment position**

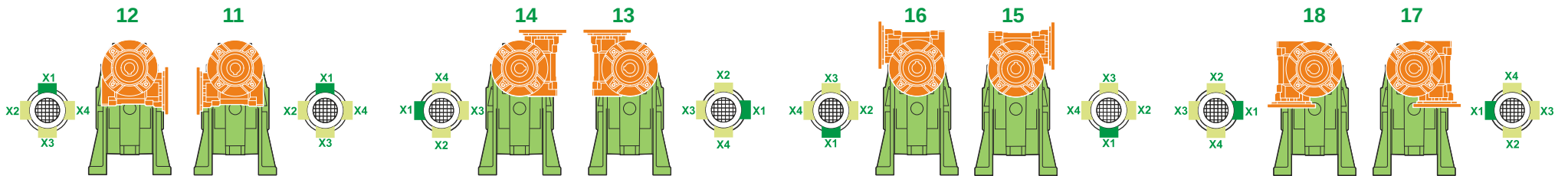

**Direction of rotation**

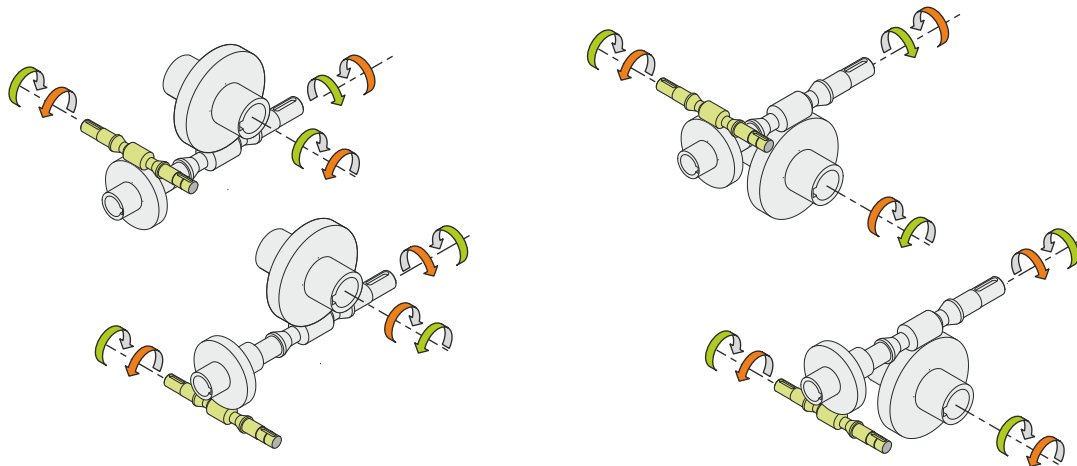

**Weight**

Gear unit [kg]	90
Electric motor [kg]	21

**Gearing data 2**

2	Axial module	8.45
2	Number of starts	1
2	Lead angle	20° 35'
2	Pressure angle	20° 35'

**Backdriving**

- Static self-locking
- Slow back-driving in case of vibrations
- Low dynamic back-driving

**M RS/RS 70/150 S (integral) 11 420 100 B14 AC 55 MT 2.2 kW 100 A4 B14 X3 B3**