

Input data

System of measurement		Metric
Input type		Gear motor
Input speed	[rpm]	1400
Output speed	[rpm]	5.66
Ratio (i=)		247.2
Frequency	[Hz]	50
Input options		IEC
Requested input power	[kW]	0.13
Service factor		1.1
Rated Power P1	[kW]	0.14

Output data

Gear unit	M TA 63/50 B3 10 247.2 63 B14 AC 24 MT 0.13 kW 63 A4 B14 X3
------------------	--

Type		TA - Worm speed reducers
Input type		M
Size		63/50
Ratio (i=)		247.2
Gearbox ratio		40.00
Pre-stage ratio		6.18
Input flange		B14
Input speed	[rpm]	1400
Output speed	[rpm]	5.66
Rated output torque	[Nm]	105.22
Service Factor		1.1
Efficiency		0.48
Inertia moment	[kgm ²]	0.000023

Gear unit configuration

Output shaft		Hollow output shaft
Fixing		Universal
Version		B3
Attachment position		10

Output radial and axial loads

Ball bearings output radial load	[N]	3200
Taper bearings output radial load	[N]	4200
Ball bearings output axial load	[N]	640
Taper bearings output axial load	[N]	840

Accessories

Hollow output shaft		AC 24
---------------------	--	-------

Electric motor

Size		63 A4
Poles		4
Power	[kW]	0.13

Electric motor configuration

Motor flange		B14
Terminal box position		X3

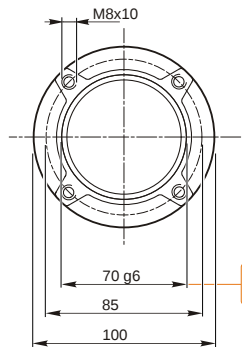
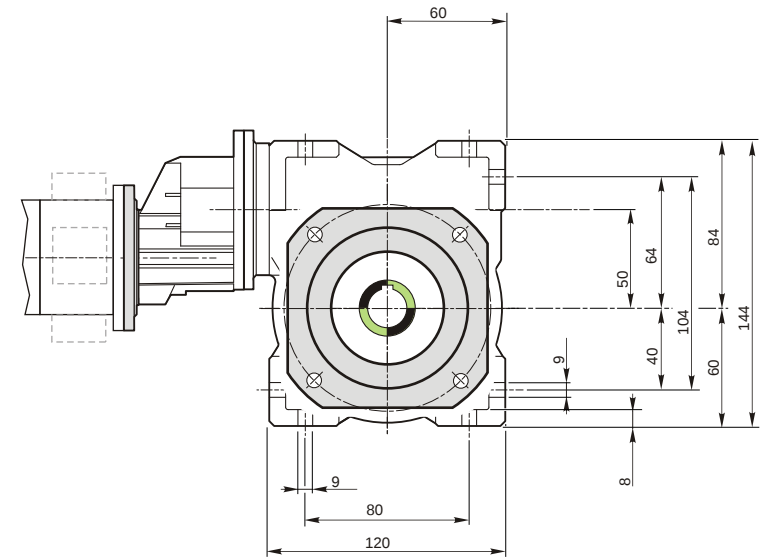
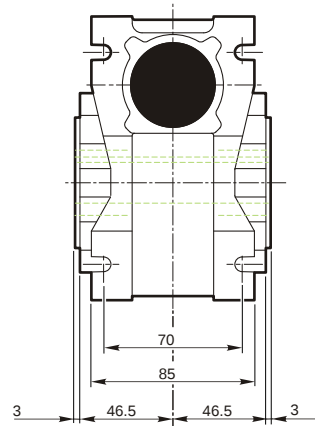
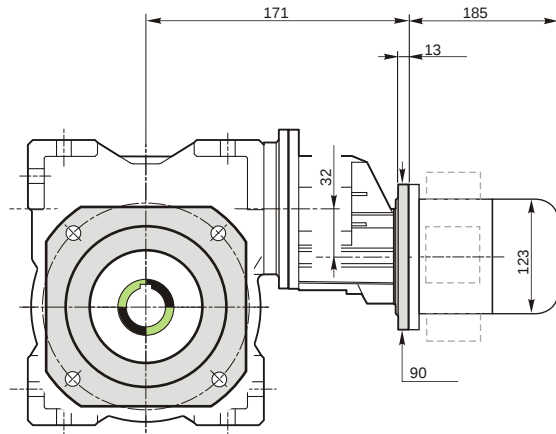

69.99
69.971

Hollow output shaft

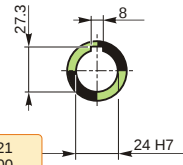

24.021
24.000

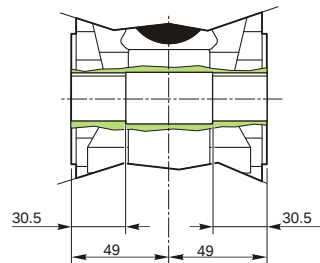

Attachment position

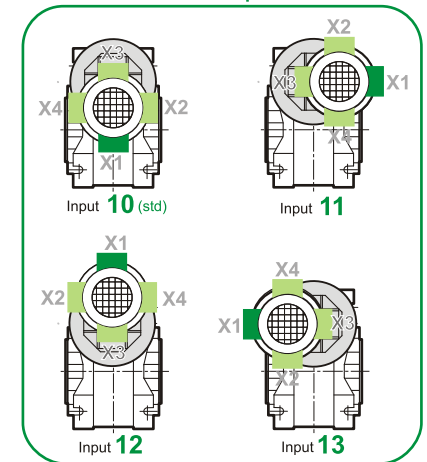

M TA 63/50 B3 10 247.2 63 B14 AC 24 MT 0.13 kW 63 A4 B14 X3

Mounting positions

B3

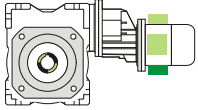

B6

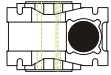

B7

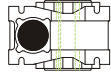

B8

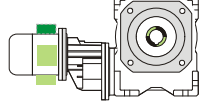

V5



V6



Terminal box position

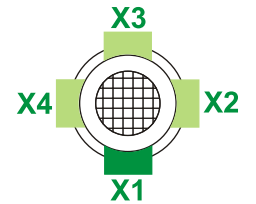

0.04	1	2	1
0.13	2	1	2



Lubricant type: Long life synthetic oil ISO VG320

Direction of rotation

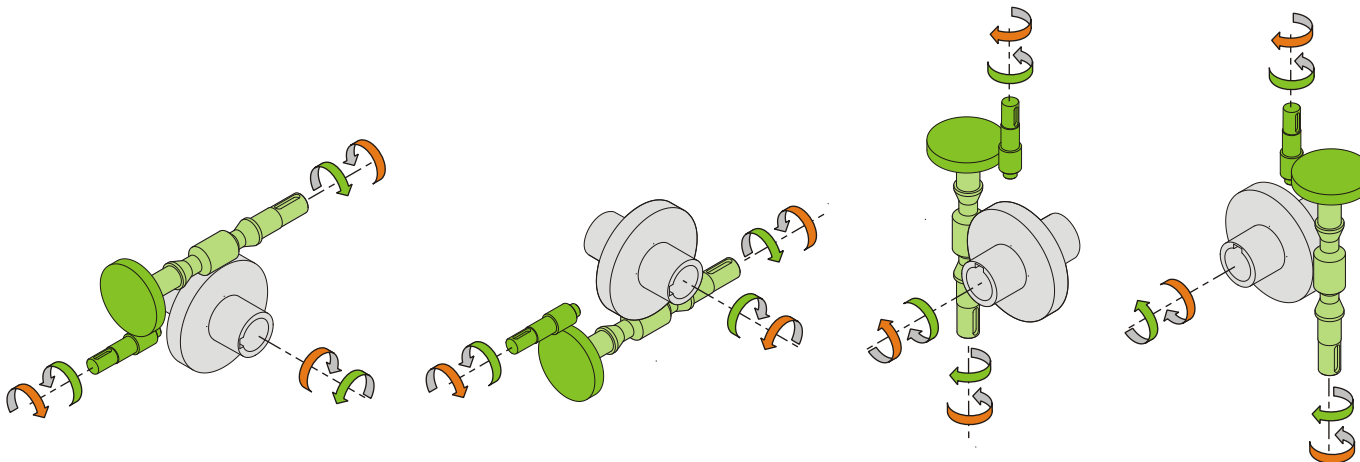

Weight

Gear unit [kg]	5.3
Electric motor [kg]	4.3

Gearing data

Axial module	1.9
Number of starts	1
Lead angle	4° 31'
Pressure angle	20°

Backdriving

Static self-locking
Slow back-driving in case of vibrations
Low dynamic back-driving

M TA 63/50 B3 10 247.2 63 B14 AC 24 MT 0.13 kW 63 A4 B14 X3