

Input data

System of measurement		Metric
Input type		Gear motor
Input speed	[rpm]	1400
Output speed	[rpm]	21.88
Ratio (i=)		64
Frequency	[Hz]	50
Input options		IEC
Requested input power	[kW]	1.5
Service factor		1
Rated Power P1	[kW]	1.56

Output data

Gear unit M TA 80/85 B3 10 64 90 B14 AC 32 MT 1.5 kW 90 L4 B14 X3

Type		TA - Worm speed reducers
Input type		M
Size		80/85
Ratio (i=)		64
Gearbox ratio		10.00
Pre-stage ratio		6.40
Input flange		B14
Input speed	[rpm]	1400
Output speed	[rpm]	21.88
Rated output torque	[Nm]	504.24
Service Factor		1
Efficiency		0.77
Inertia moment	[kgm ²]	0.000266

Gear unit configuration

Output shaft		Hollow output shaft
Fixing		Universal
Version		B3
Attachment position		10

Output radial and axial loads

Ball bearings output radial load	[N]	6900
Taper bearings output radial load	[N]	9100
Ball bearings output axial load	[N]	1380
Taper bearings output axial load	[N]	1820

Accessories

Hollow output shaft		AC 32
---------------------	--	-------

Electric motor

Size		90 L4
Poles		4
Power	[kW]	1.5

Electric motor configuration

Motor flange		B14
Terminal box position		X3

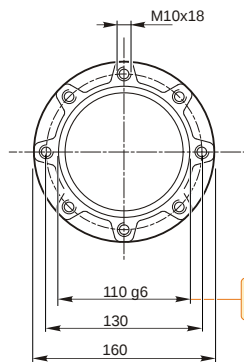
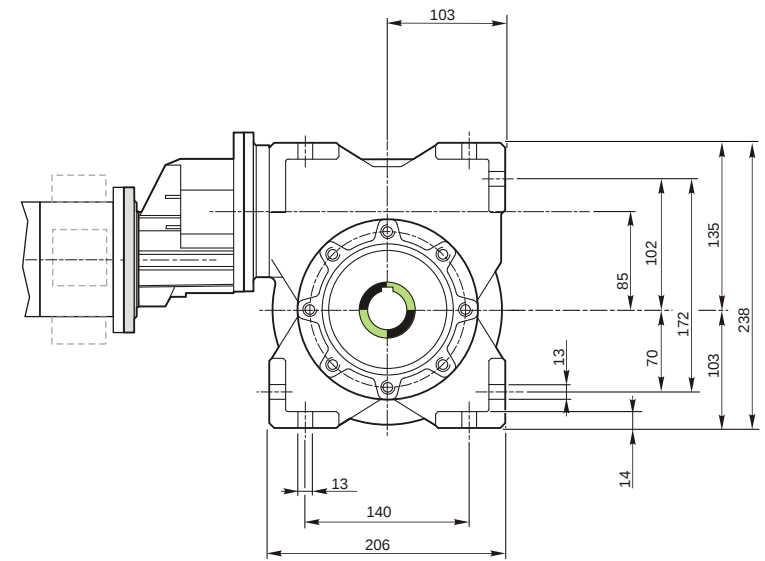
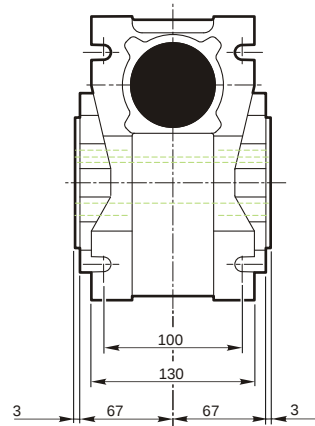
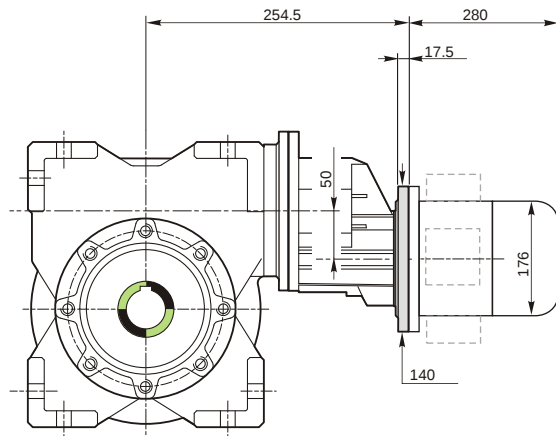

109.988
109.966

Hollow output shaft

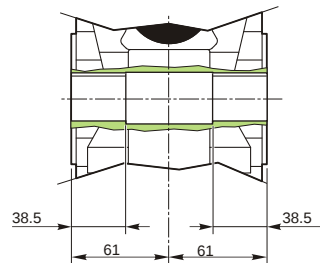
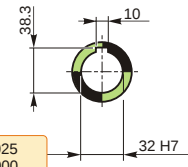

Attachment position

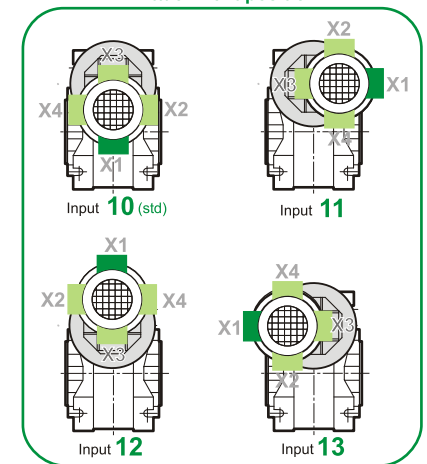

M TA 80/85 B3 10 64 90 B14 AC 32 MT 1.5 kW 90 L4 B14 X3

Mounting positions

B3

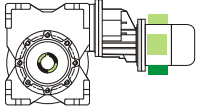

B6

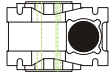

B7

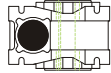

B8

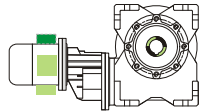

V5

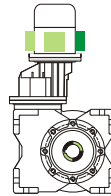

V6



Terminal box position

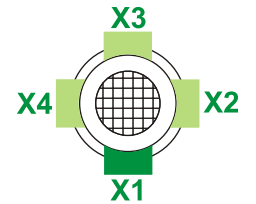

0.1	1	2	1
0.6	2	1	2

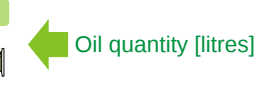

Lubricant type: Long life synthetic oil ISO VG320

Direction of rotation

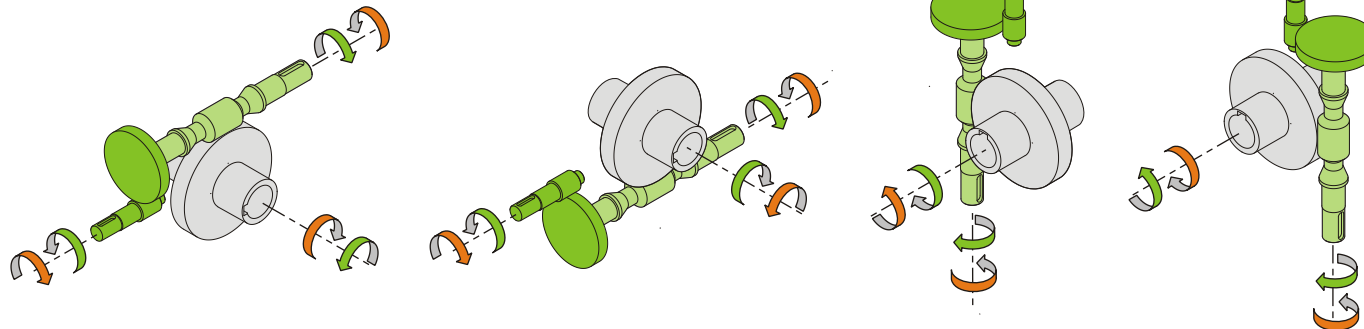

Weight

Gear unit [kg]	17.5
Electric motor [kg]	13.5

Gearing data

Axial module	4.4
Number of starts	3
Lead angle	19° 09'
Pressure angle	20°

Backdriving

- Static back-driving
- Quick back-driving
- Dynamic back-driving

M TA 80/85 B3 10 64 90 B14 AC 32 MT 1.5 kW 90 L4 B14 X3