

Input data

System of measurement		Metric
Input type		Gear motor
Input speed	[rpm]	1400
Output speed	[rpm]	14.66
Ratio (i=)		95.48
Frequency	[Hz]	50
Input options		IEC
Requested input power	[kW]	1.5
Service factor		1.5
Rated Power P1	[kW]	2.23

Output data

Gear unit **M TA 80/110 B3 10 95.48 90 B14 AC 42 MT 1.5 kW 90 L4 B14 X3**

Type		TA - Worm speed reducers
Input type		M
Size		80/110
Ratio (i=)		95.48
Gearbox ratio		28.00
Pre-stage ratio		3.41
Input flange		B14
Input speed	[rpm]	1400
Output speed	[rpm]	14.66
Rated output torque	[Nm]	644.8
Service Factor		1.5
Efficiency		0.66
Inertia moment	[kgm ²]	0.000518

Gear unit configuration

Output shaft		Hollow output shaft
Fixing		Universal
Version		B3
Attachment position		10

Output radial and axial loads

Ball bearings output radial load	[N]	9750
Taper bearings output radial load	[N]	11100
Ball bearings output axial load	[N]	1950
Taper bearings output axial load	[N]	2220

Accessories

Hollow output shaft		AC 42
---------------------	--	-------

Electric motor

Size		90 L4
Poles		4
Power	[kW]	1.5

Electric motor configuration

Motor flange		B14
Terminal box position		X3

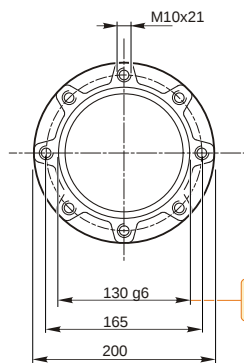
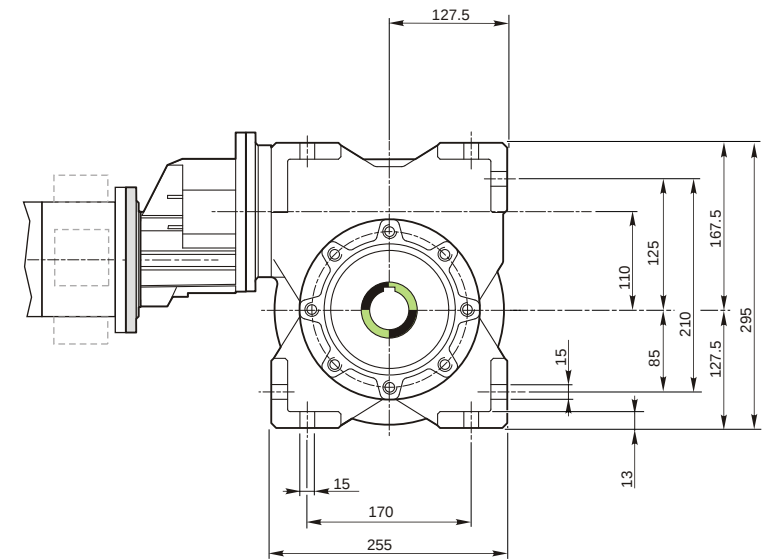
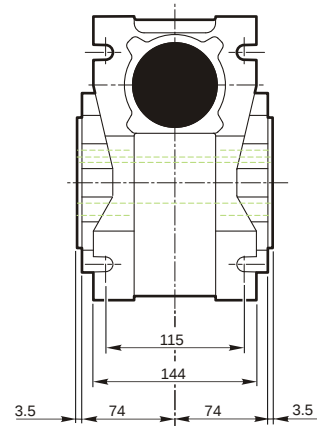
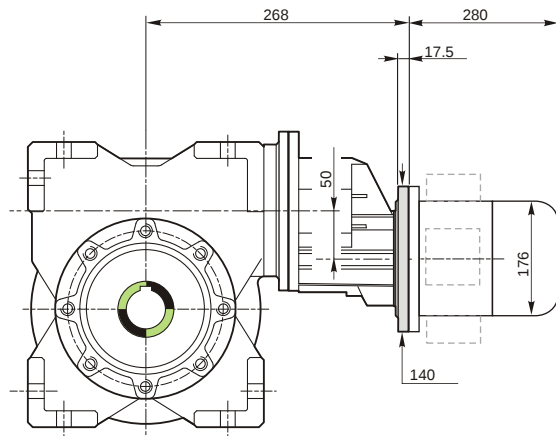

129.986
129.961

Hollow output shaft

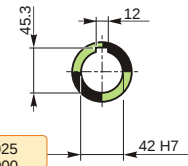

42.025
42.000

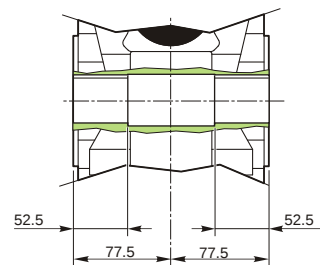

Attachment position

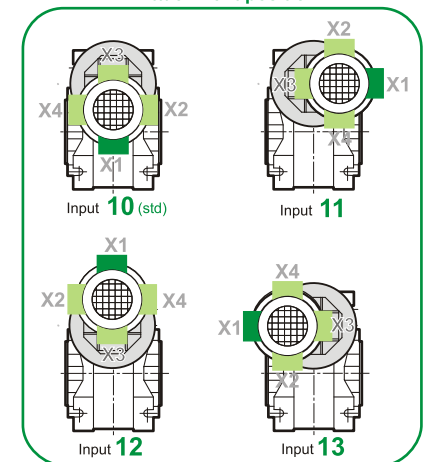

M TA 80/110 B3 10 95.48 90 B14 AC 42 MT 1.5 kW 90 L4 B14 X3

Mounting positions

B3

B6

B7

B8

V5

V6

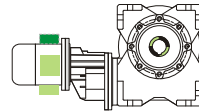
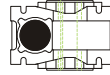
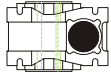
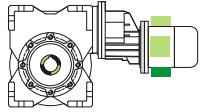

Terminal box position

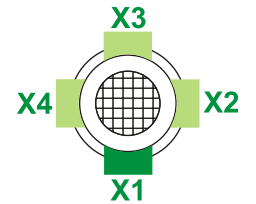

0.1

1



1.5

2



← Oil quantity [litres]

Lubricant type: Long life synthetic oil ISO VG320

Direction of rotation

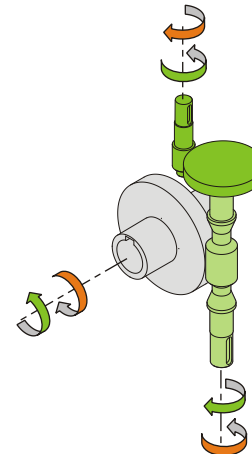
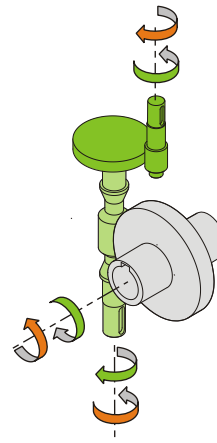
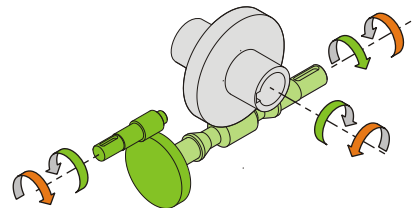
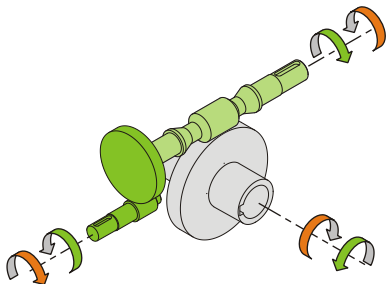

Weight

Gear unit [kg]	43
Electric motor [kg]	13.5

Gearing data

Axial module	6.1
Number of starts	1
Lead angle	7° 04'
Pressure angle	20°

Backdriving

Static self-locking
Slow back-driving in case of vibrations
Low dynamic back-driving

M TA 80/110 B3 10 95.48 90 B14 AC 42 MT 1.5 kW 90 L4 B14 X3