

Input data

System of measurement		Metric
Input type		Gear motor
Input speed	[rpm]	1400
Output speed	[rpm]	3.91
Ratio (i=)		358.4
Frequency	[Hz]	50
Input options		IEC
Requested input power	[kW]	0.75
Service factor		1
Rated Power P1	[kW]	0.78

Output data

Gear unit	M TA 80/110 B3 10 358.4 80 B14 AC 42 MT 0.75 kW 80 B4 B14 X3
------------------	---

Type		TA - Worm speed reducers
Input type		M
Size		80/110
Ratio (i=)		358.4
Gearbox ratio		56.00
Pre-stage ratio		6.40
Input flange		B14
Input speed	[rpm]	1400
Output speed	[rpm]	3.91
Rated output torque	[Nm]	953.47
Service Factor		1
Efficiency		0.52
Inertia moment	[kgm ²]	0.000298

Gear unit configuration

Output shaft		Hollow output shaft
Fixing		Universal
Version		B3
Attachment position		10

Output radial and axial loads

Ball bearings output radial load	[N]	9800
Taper bearings output radial load	[N]	11100
Ball bearings output axial load	[N]	1960
Taper bearings output axial load	[N]	2220

Accessories

Hollow output shaft		AC 42
---------------------	--	-------

Electric motor

Size		80 B4
Poles		4
Power	[kW]	0.75

Electric motor configuration

Motor flange		B14
Terminal box position		X3

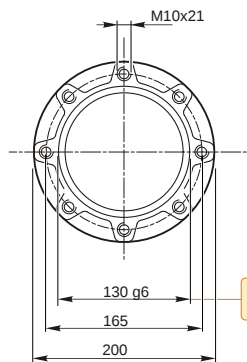
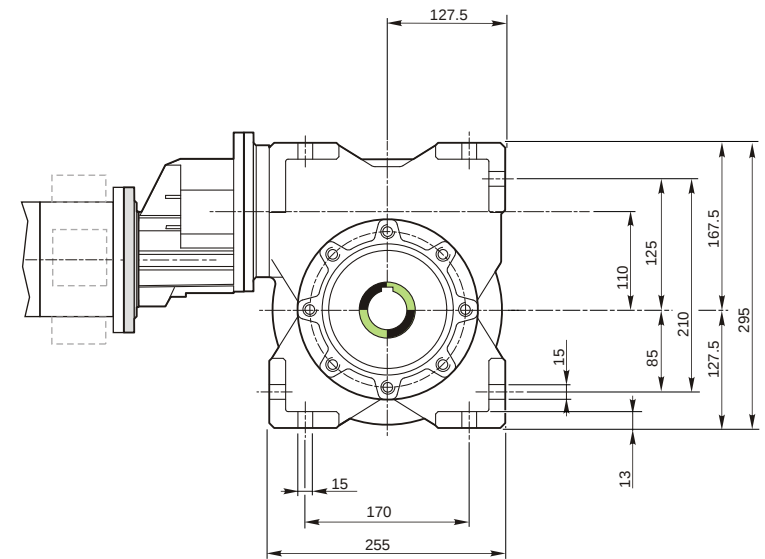
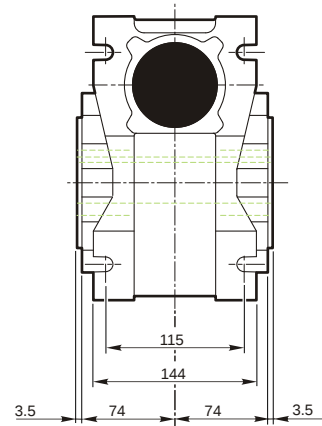
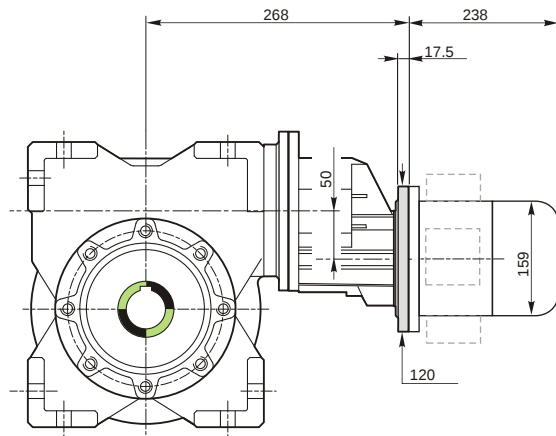

129.986
129.961

Hollow output shaft

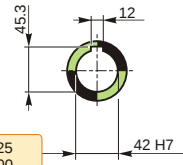

42.025
42.000

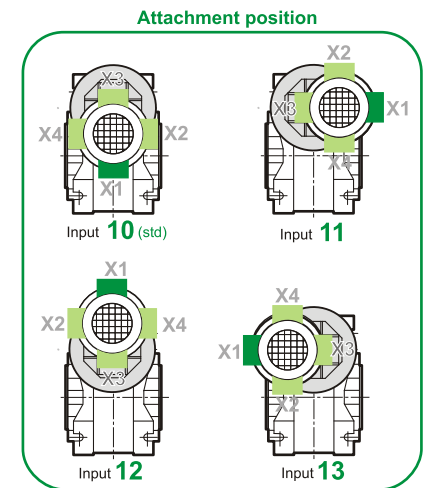
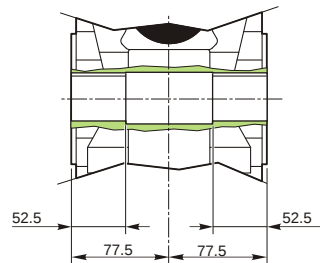

M TA 80/110 B3 10 358.4 80 B14 AC 42 MT 0.75 kW 80 B4 B14 X3

Mounting positions

B3

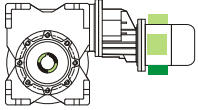

B6

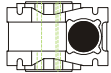

B7

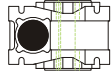

B8

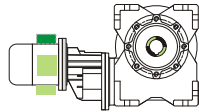

V5



V6



Terminal box position

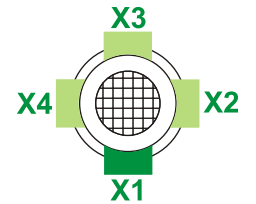

0.1

1



1.5

2

← Oil quantity [litres]

Lubricant type: Long life synthetic oil ISO VG320

Direction of rotation

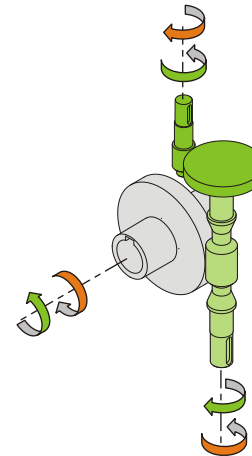
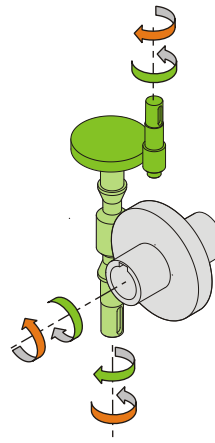
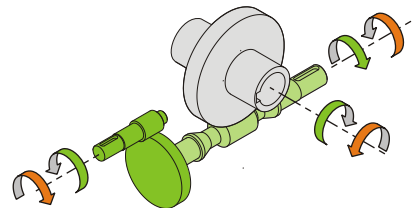
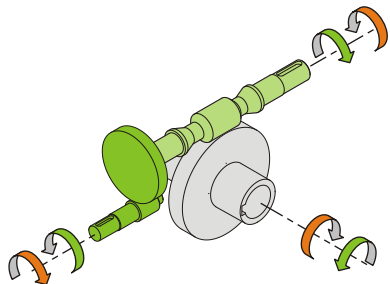

Weight

Gear unit [kg]	43
Electric motor [kg]	9.8

Gearing data

Axial module	3.2
Number of starts	1
Lead angle	4° 29'
Pressure angle	20°

Backdriving

Static self-locking
Slow back-driving in case of vibrations
Low dynamic back-driving

M TA 80/110 B3 10 358.4 80 B14 AC 42 MT 0.75 kW 80 B4 B14 X3