

### Input data

System of measurement		Metric
Input type		Gear motor
Input speed	[rpm]	1400
Output speed	[rpm]	32.36
Ratio (i=)		43.26
Frequency	[Hz]	50
Input options		IEC
Requested input power	[kW]	0.18
Service factor		2
Rated Power P1	[kW]	0.36

### Output data

**Gear unit** **M RA 63/40 PC 10 43.26 63 B14 AC 19 MT 0.18 kW 63 B4 B14 X3 B3**

Type		RA - Worm speed reducers
Input type		M
Size		63/40
Ratio (i=)		43.26
Gearbox ratio		7.00
Pre-stage ratio		6.18
Input flange		B14
Mounting position		B3
Input speed	[rpm]	1400
Output speed	[rpm]	32.36
Rated output torque	[Nm]	43.02
Service Factor		2
Efficiency		0.81
Inertia moment	[kgm <sup>2</sup> ]	0.000022

#### Gear unit configuration

Output shaft		Hollow output shaft
Fixing		Shaft mounting
Version		PC
Attachment position		10

#### Output radial and axial loads

Ball bearings output radial load	[N]	1650
Taper bearings output radial load	[N]	2350
Ball bearings output axial load	[N]	330
Taper bearings output axial load	[N]	470

#### Accessories

Hollow output shaft		AC 19
---------------------	--	-------

#### Electric motor

Size		63 B4
Poles		4
Power	[kW]	0.18

#### Electric motor configuration

Motor flange		B14
Terminal box position		X3

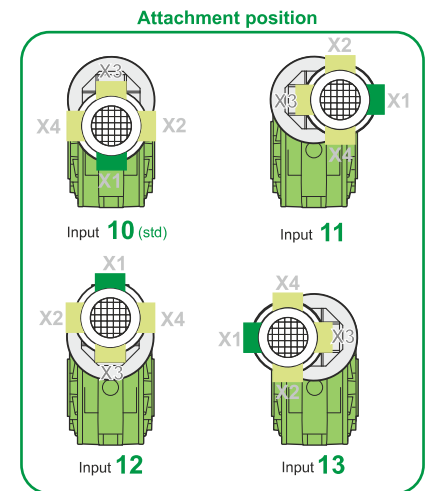
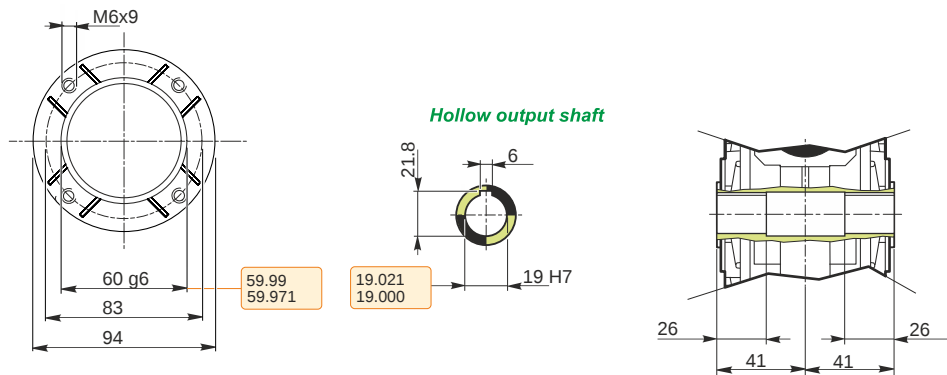
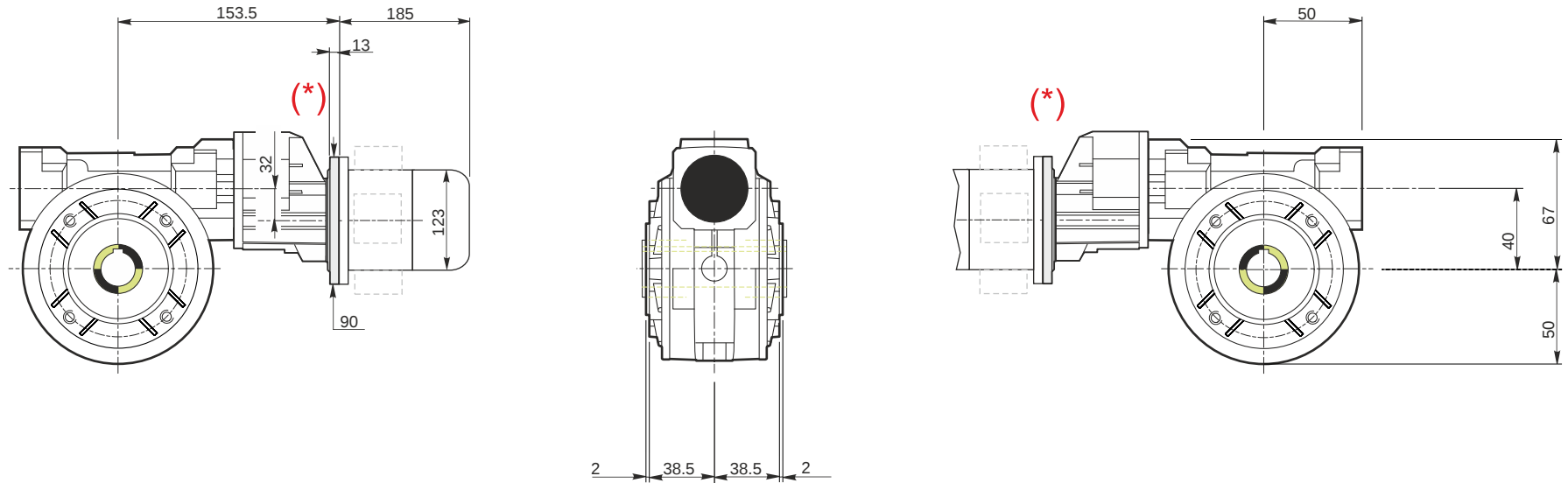

**M RA 63/40 PC 10 43.26 63 B14 AC 19 MT 0.18 kW 63 B4 B14 X3 B3**

### Mounting positions

B3

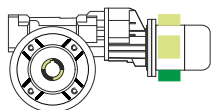

B6

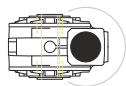

B7

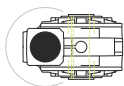

B8

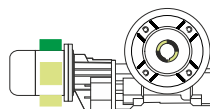

V5

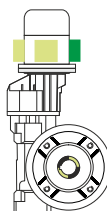

V6



Terminal box position

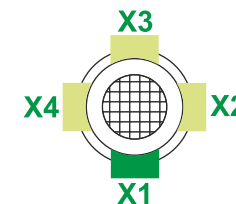

0.04

1

0.08

2

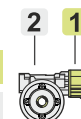

Oil quantity [litres]

Lubricant type: Long life synthetic oil ISO VG320

### Direction of rotation

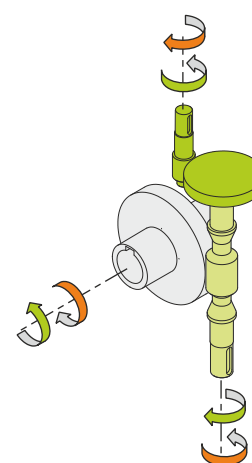
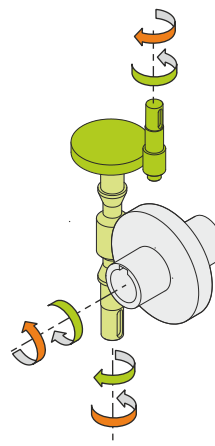
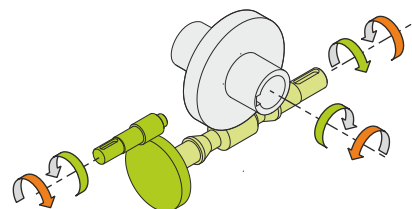
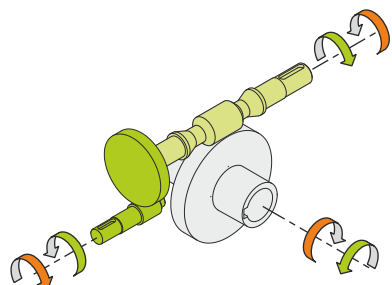

### Weight

Gear unit [kg]	4
Electric motor [kg]	4.3

### Gearing data

Axial module	2.1
Number of starts	4
Lead angle	21° 36'
Pressure angle	20°

### Backdriving

Static back-driving  
Quick back-driving  
Dynamic back-driving

**M RA 63/40 PC 10 43.26 63 B14 AC 19 MT 0.18 kW 63 B4 B14 X3 B3**