

### Input data

System of measurement		Metric
Input type		Gear motor
Input speed	[rpm]	1400
Output speed	[rpm]	15.1
Ratio (i=)		92.7
Frequency	[Hz]	50
Input options		IEC
Requested input power	[kW]	0.13
Service factor		1.4
Rated Power P1	[kW]	0.19

### Output data

<b>Gear unit</b>	<b>M RA 63/40 PC 10 92.7 63 B14 AC 19 MT 0.13 kW 63 A4 B14 X3 B3</b>	
------------------	--	--

Type		RA - Worm speed reducers
Input type		M
Size		63/40
Ratio (i=)		92.7
Gearbox ratio		15.00
Pre-stage ratio		6.18
Input flange		B14
Mounting position		B3
Input speed	[rpm]	1400
Output speed	[rpm]	15.1
Rated output torque	[Nm]	59.19
Service Factor		1.4
Efficiency		0.72
Inertia moment	[kgm <sup>2</sup> ]	0.000022

#### Gear unit configuration

Output shaft		Hollow output shaft
Fixing		Shaft mounting
Version		PC
Attachment position		10

#### Output radial and axial loads

Ball bearings output radial load	[N]	2250
Taper bearings output radial load	[N]	2600
Ball bearings output axial load	[N]	450
Taper bearings output axial load	[N]	520

#### Accessories

Hollow output shaft		AC 19
---------------------	--	-------

#### Electric motor

Size		63 A4
Poles		4
Power	[kW]	0.13

#### Electric motor configuration

Motor flange		B14
Terminal box position		X3

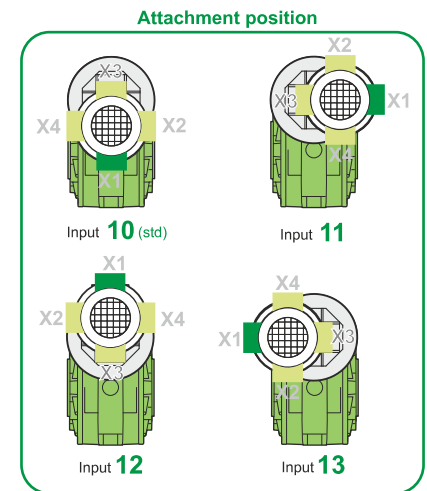
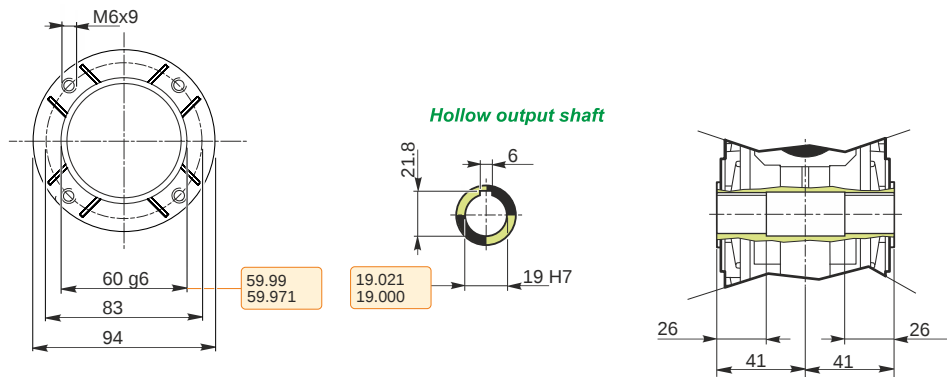
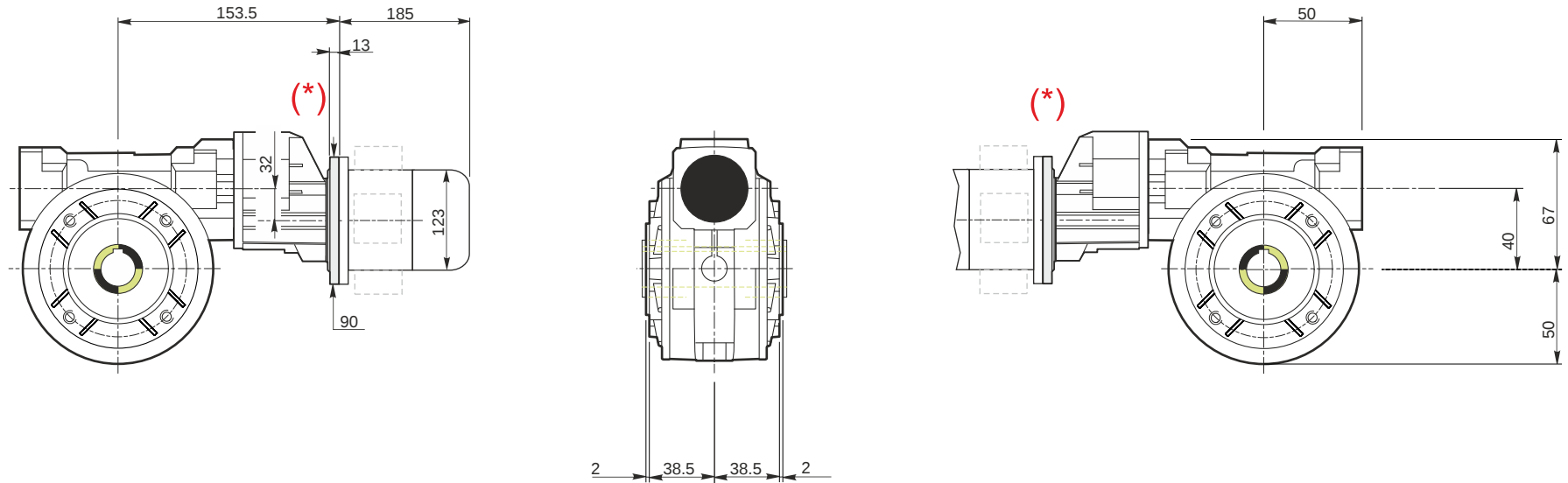

### Mounting positions

B3

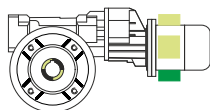

B6

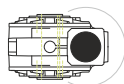

B7

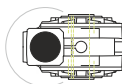

B8

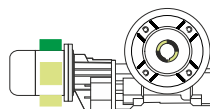

V5

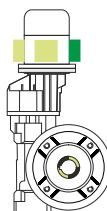

V6



Terminal box position

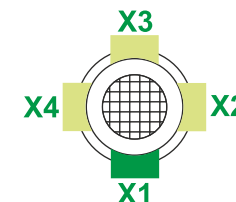

0.04

1

0.08

2

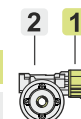

Oil quantity [litres]

Lubricant type: Long life synthetic oil ISO VG320

### Direction of rotation

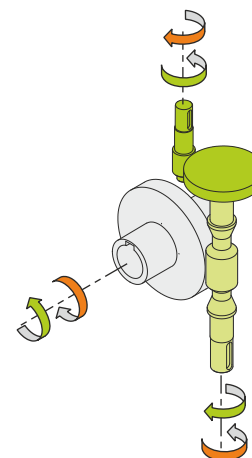
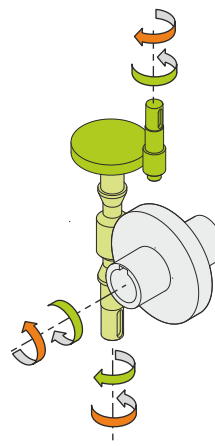
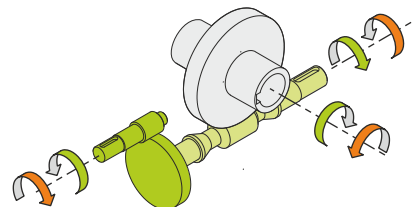
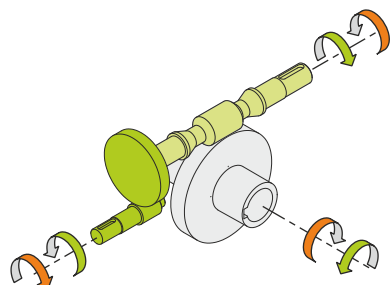

### Weight

Gear unit [kg]	4
Electric motor [kg]	4.3

### Gearing data

Axial module	2
Number of starts	2
Lead angle	11° 18'
Pressure angle	20°

### Backdriving

Variable static self-locking  
Quick back-driving in case of vibrations  
Dynamic back-driving

**M RA 63/40 PC 10 92.7 63 B14 AC 19 MT 0.13 kW 63 A4 B14 X3 B3**