

Input data

System of measurement		Metric
Input type		Gear motor
Input speed	[rpm]	1400
Output speed	[rpm]	7.81
Ratio (i=)		179.2
Frequency	[Hz]	50
Input options		IEC
Requested input power	[kW]	0.37
Service factor		0.9
Rated Power P1	[kW]	0.34

Output data

Gear unit	M RA 71/60 PC 10 179.2 71 B14 AC 25 MT 0.37 kW 71 B4 B14 X3 B3
------------------	---

Type		RA - Worm speed reducers
Input type		M
Size		71/60
Ratio (i=)		179.2
Gearbox ratio		28.00
Pre-stage ratio		6.40
Input flange		B14
Mounting position		B3
Input speed	[rpm]	1400
Output speed	[rpm]	7.81
Rated output torque	[Nm]	257.8
Service Factor		0.9
Efficiency		0.57
Inertia moment	[kgm ²]	0.000047

Gear unit configuration

Output shaft		Hollow output shaft
Fixing		Shaft mounting
Version		PC
Attachment position		10

Output radial and axial loads

Ball bearings output radial load	[N]	5600
Taper bearings output radial load	[N]	6600
Ball bearings output axial load	[N]	1120
Taper bearings output axial load	[N]	1320

Accessories

Hollow output shaft		AC 25
---------------------	--	-------

Electric motor

Size		71 B4
Poles		4
Power	[kW]	0.37

Electric motor configuration

Motor flange		B14
Terminal box position		X3

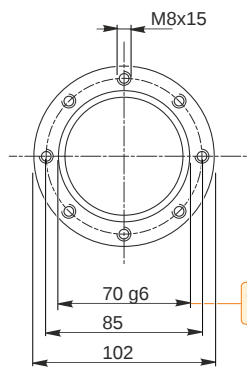
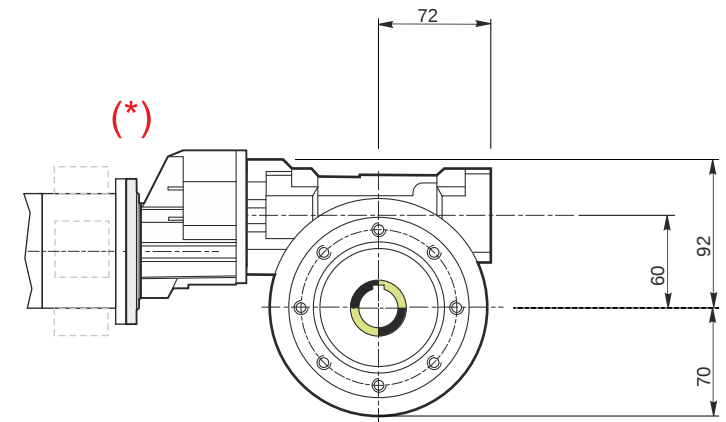
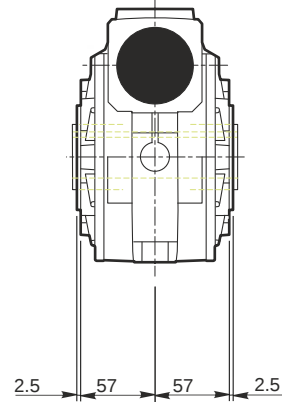
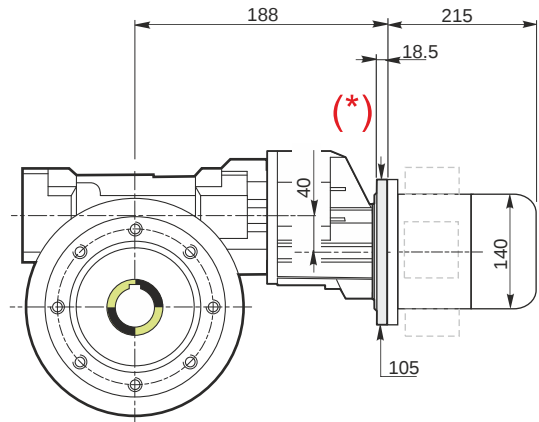

Hollow output shaft

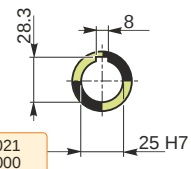

69.99
69.971

25.021
25.000

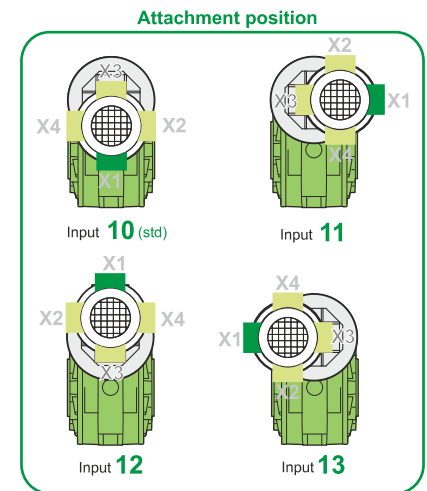
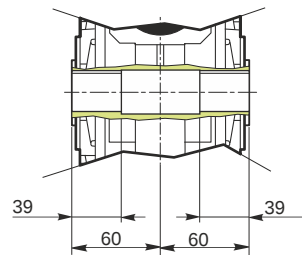

Mounting positions

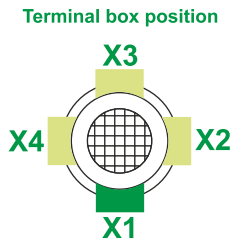
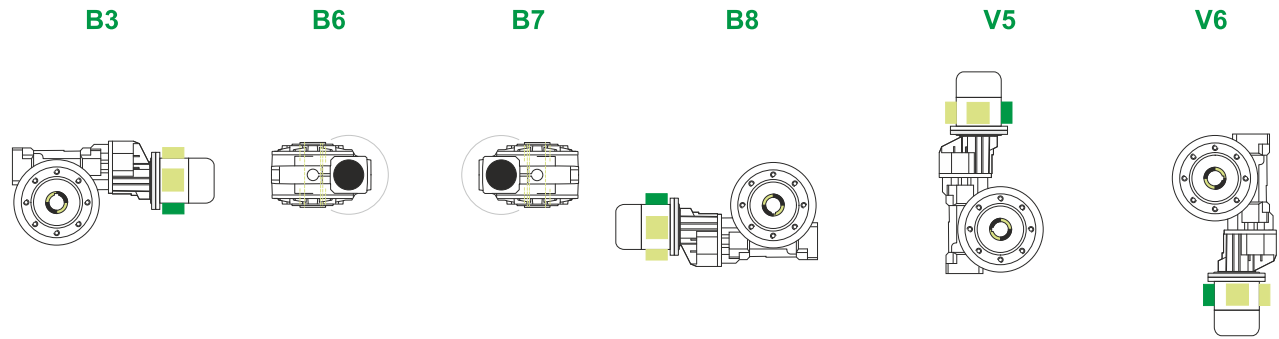

0.05	1
0.23	2



Lubricant type: Long life synthetic oil ISO VG320

Direction of rotation

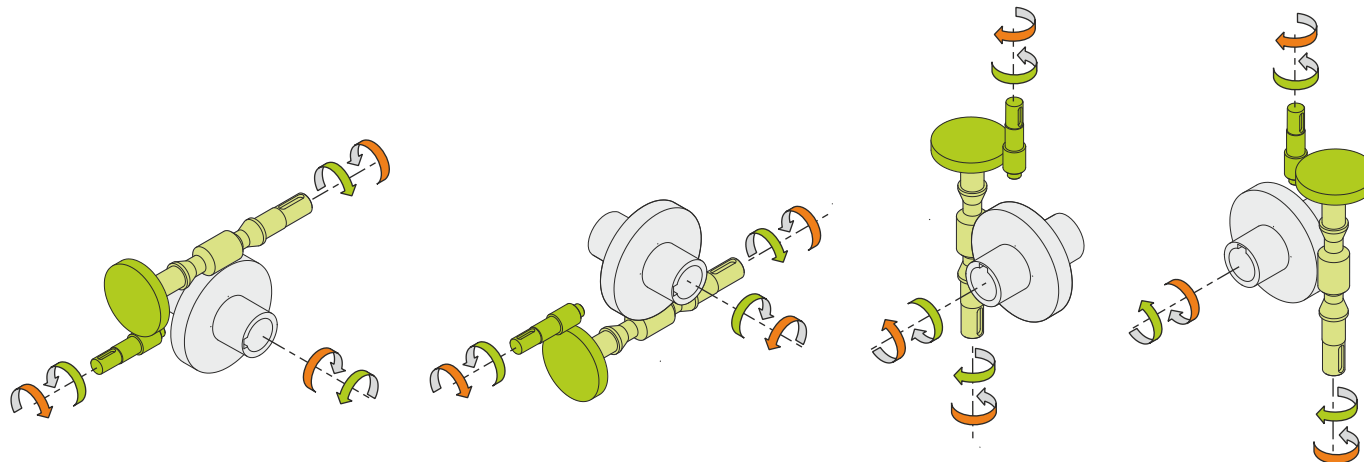

Weight

Gear unit [kg]	9.3
Electric motor [kg]	6.2

Gearing data

Axial module	3.3
Number of starts	1
Lead angle	6° 49'
Pressure angle	20°

Backdriving

Static self-locking
Slow back-driving in case of vibrations
Low dynamic back-driving

M RA 71/60 PC 10 179.2 71 B14 AC 25 MT 0.37 kW 71 B4 B14 X3 B3