

Input data

System of measurement		Metric
Input type		Gear motor
Input speed	[rpm]	1400
Output speed	[rpm]	4.46
Ratio (i=)		313.6
Frequency	[Hz]	50
Input options		IEC
Requested input power	[kW]	0.25
Service factor		1
Rated Power P1	[kW]	0.25

Output data

Gear unit	M RA 71/70 PC 10 313.6 71 B14 AC 28 MT 0.25 kW 71 A4 B14 X3 B3
------------------	---

Type		RA - Worm speed reducers
Input type		M
Size		71/70
Ratio (i=)		313.6
Gearbox ratio		49.00
Pre-stage ratio		6.40
Input flange		B14
Mounting position		B3
Input speed	[rpm]	1400
Output speed	[rpm]	4.46
Rated output torque	[Nm]	267.4
Service Factor		1
Efficiency		0.5
Inertia moment	[kgm ²]	0.000051

Gear unit configuration

Output shaft		Hollow output shaft
Fixing		Shaft mounting
Version		PC
Attachment position		10

Output radial and axial loads

Ball bearings output radial load	[N]	6700
Taper bearings output radial load	[N]	7900
Ball bearings output axial load	[N]	1340
Taper bearings output axial load	[N]	1580

Accessories

Hollow output shaft		AC 28
---------------------	--	-------

Electric motor

Size		71 A4
Poles		4
Power	[kW]	0.25

Electric motor configuration

Motor flange		B14
Terminal box position		X3

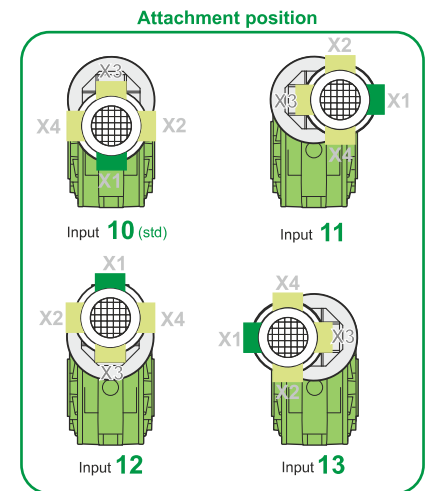
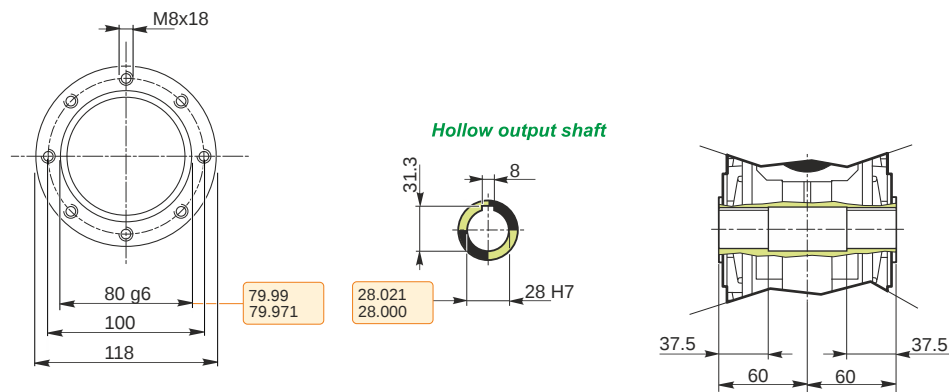
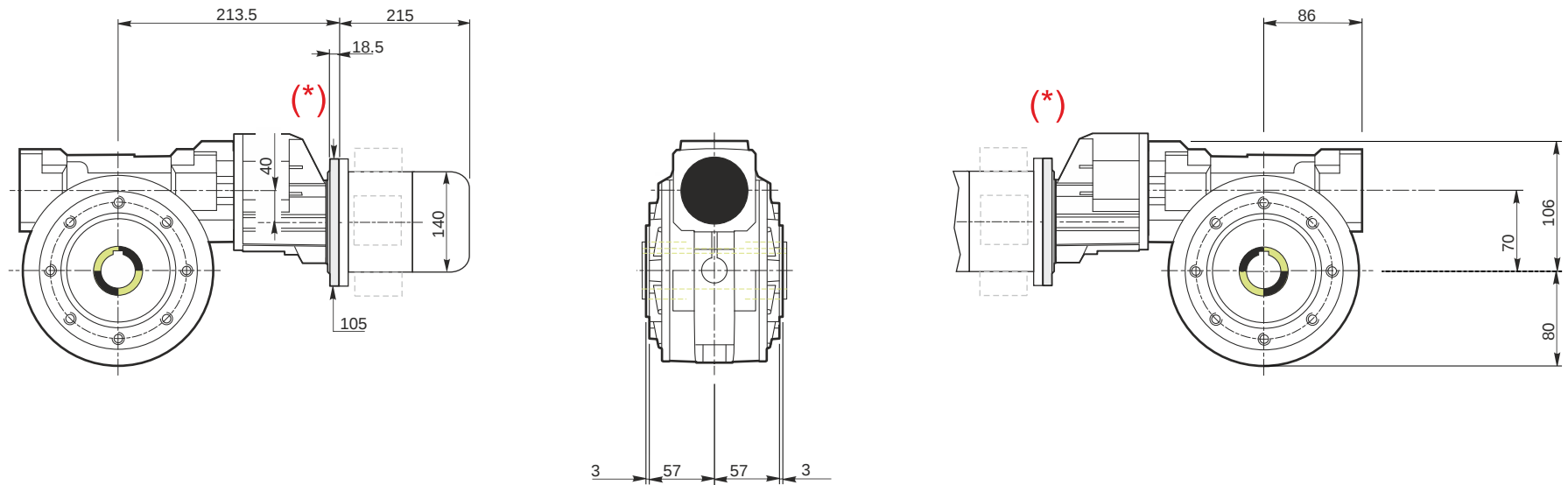

M RA 71/70 PC 10 313.6 71 B14 AC 28 MT 0.25 kW 71 A4 B14 X3 B3

Mounting positions

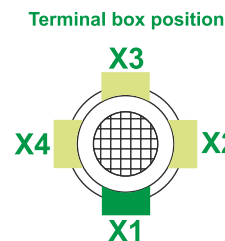
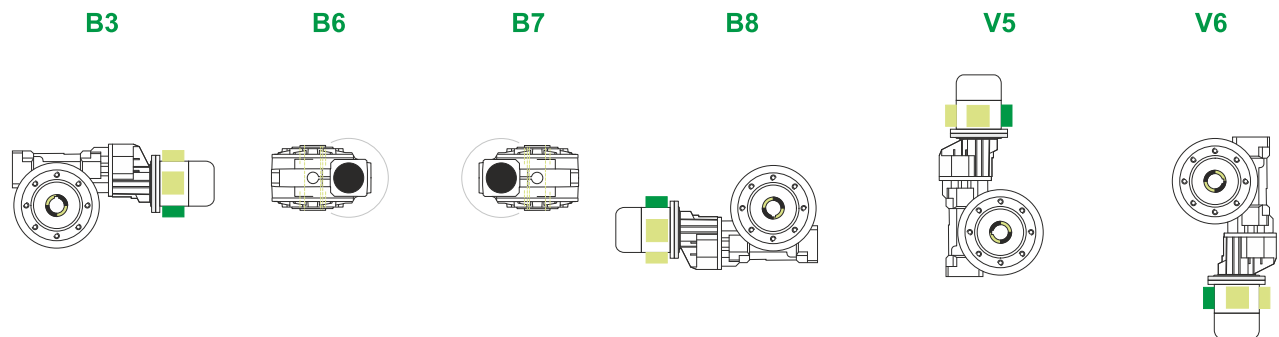

0.05	1
0.35	2



Lubricant type: Long life synthetic oil ISO VG320

Direction of rotation

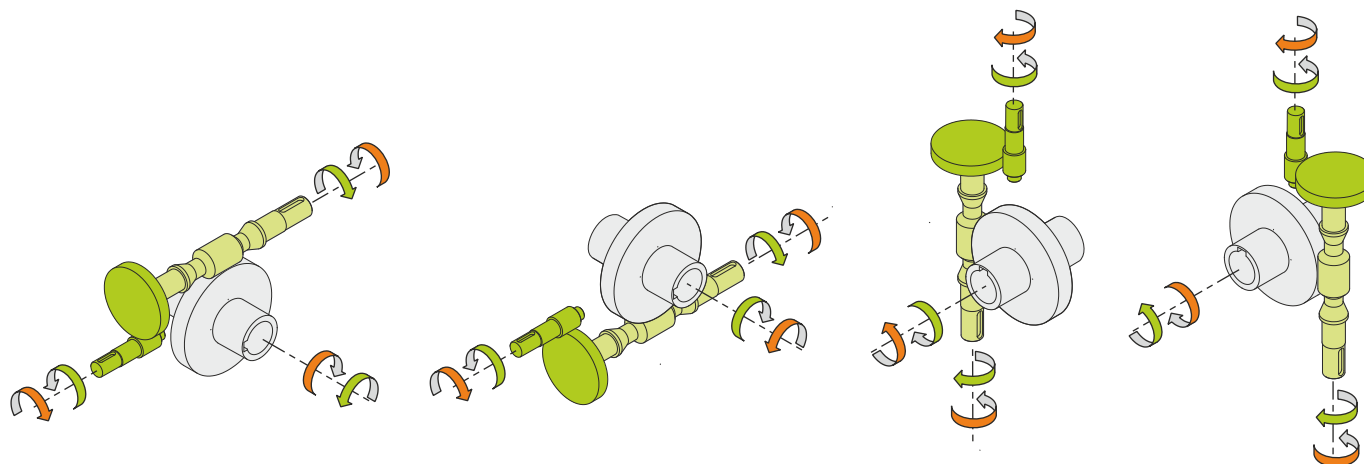

Weight

Gear unit [kg]	11.8
Electric motor [kg]	6.2

Gearing data

Axial module	2.3
Number of starts	1
Lead angle	4° 48'
Pressure angle	20°

Backdriving

Static self-locking
Slow back-driving in case of vibrations
Low dynamic back-driving