

Input data

System of measurement		Metric
Input type		Gear motor
Input speed	[rpm]	1400
Output speed	[rpm]	14.58
Ratio (i=)		96
Frequency	[Hz]	50
Input options		IEC
Requested input power	[kW]	1.1
Service factor		1
Rated Power P1	[kW]	1.09

Output data

Gear unit **M RA 80/85 PC 10 96 90 B14 AC 32 MT 1.1 kW 90 S4 B14 X3 B3**

Type		RA - Worm speed reducers
Input type		M
Size		80/85
Ratio (i=)		96
Gearbox ratio		15.00
Pre-stage ratio		6.40
Input flange		B14
Mounting position		B3
Input speed	[rpm]	1400
Output speed	[rpm]	14.58
Rated output torque	[Nm]	518.65
Service Factor		1
Efficiency		0.72
Inertia moment	[kgm ²]	0.000265

Gear unit configuration

Output shaft		Hollow output shaft
Fixing		Shaft mounting
Version		PC
Attachment position		10

Output radial and axial loads

Ball bearings output radial load	[N]	8150
Taper bearings output radial load	[N]	9400
Ball bearings output axial load	[N]	1630
Taper bearings output axial load	[N]	1880

Accessories

Hollow output shaft		AC 32
---------------------	--	-------

Electric motor



Size		90 S4
Poles		4
Power	[kW]	1.1

Electric motor configuration

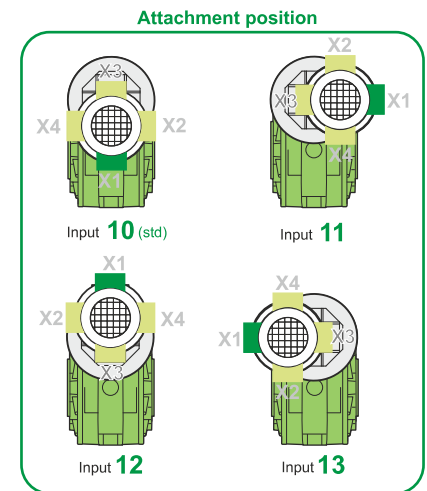
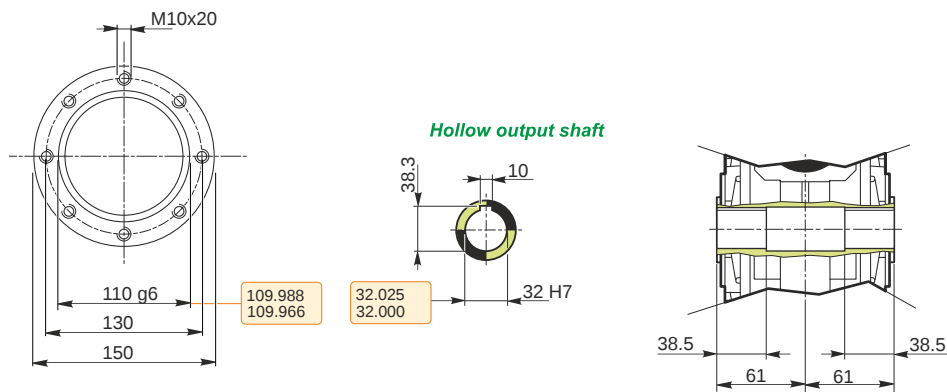
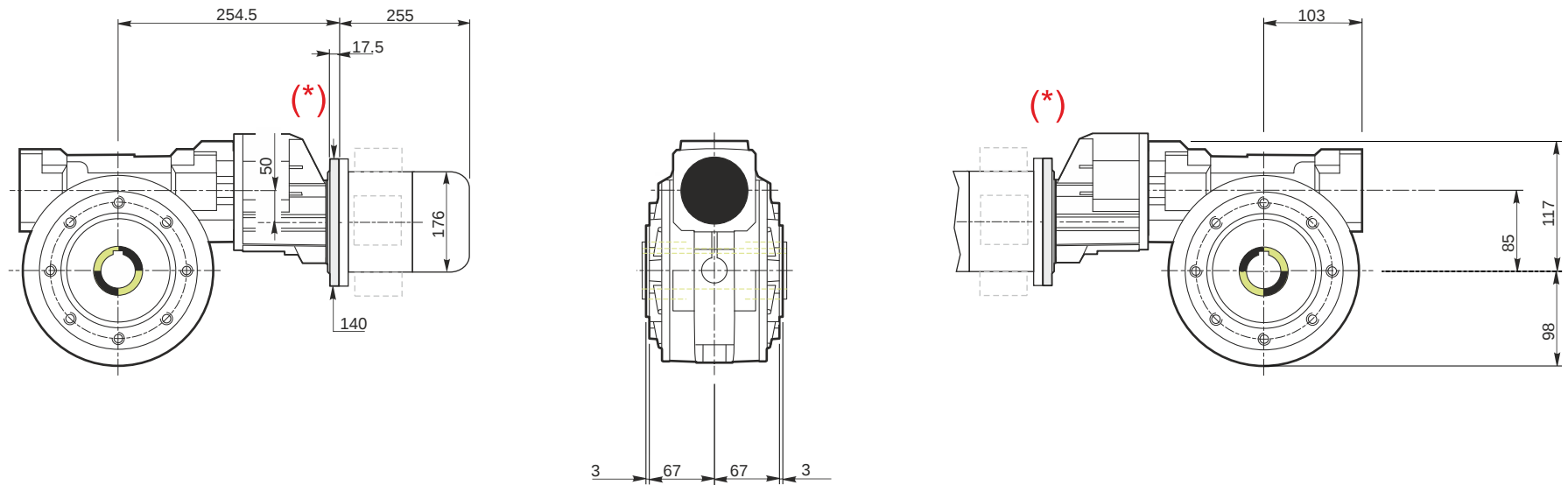
Motor flange		B14
Terminal box position		X3

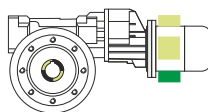
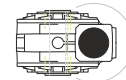
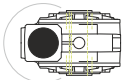
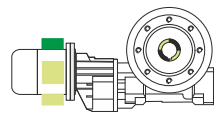
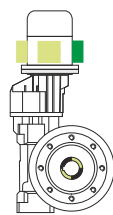

Mounting positions

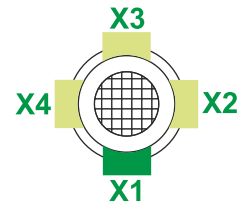
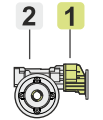
B3	B6	B7	B8	V5	V6	
						Terminal box position 
0.1				1		 ← Oil quantity [litres]
0.6				2		

Lubricant type: Long life synthetic oil ISO VG320

Direction of rotation

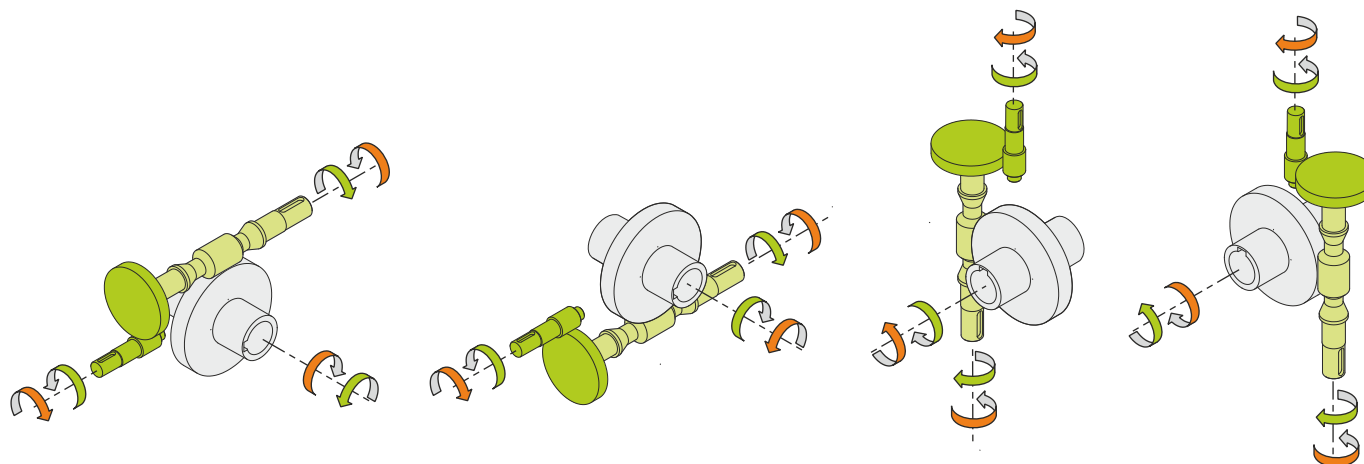

Weight

Gear unit [kg]	17.5
Electric motor [kg]	12

Gearing data

Axial module	4.4
Number of starts	2
Lead angle	13° 02'
Pressure angle	20°

Backdriving

Static back-driving
Quick back-driving
Dynamic back-driving