

### Input data

System of measurement		Metric
Input type		Gear motor
Input speed	[rpm]	1400
Output speed	[rpm]	8.03
Ratio (i=)		174.44
Frequency	[Hz]	50
Input options		IEC
Requested input power	[kW]	1.5
Service factor		1
Rated Power P1	[kW]	1.56

### Output data

**Gear unit** **M RA 100/110 PC 10 174.44 90 B14 AC 42 MT 1.5 kW 90 L4 B14 X3 B3**

Type		RA - Worm speed reducers
Input type		M
Size		100/110
Ratio (i=)		174.44
Gearbox ratio		28.00
Pre-stage ratio		6.23
Input flange		B14
Mounting position		B3
Input speed	[rpm]	1400
Output speed	[rpm]	8.03
Rated output torque	[Nm]	1124.48
Service Factor		1
Efficiency		0.63

#### Gear unit configuration

Output shaft		Hollow output shaft
Fixing		Shaft mounting
Version		PC
Attachment position		10

#### Output radial and axial loads

Ball bearings output radial load	[N]	9800
Taper bearings output radial load	[N]	11100
Ball bearings output axial load	[N]	1960
Taper bearings output axial load	[N]	2220

#### Accessories

Hollow output shaft		AC 42
---------------------	--	-------

#### Electric motor

Size		90 L4
Poles		4
Power	[kW]	1.5

#### Electric motor configuration

Motor flange		B14
Terminal box position		X3

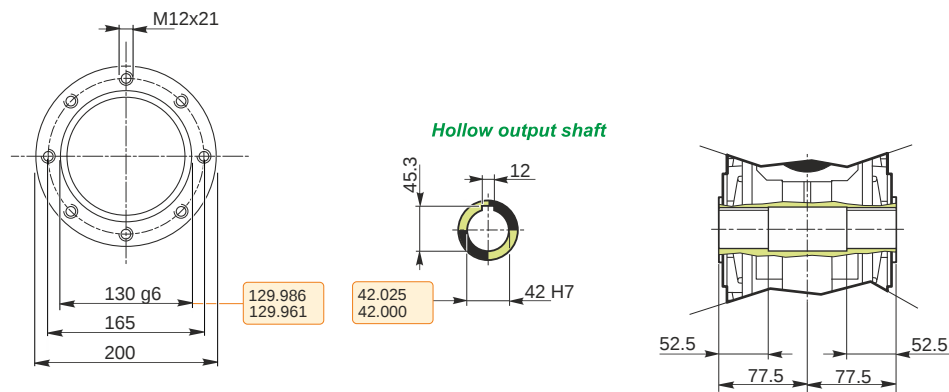
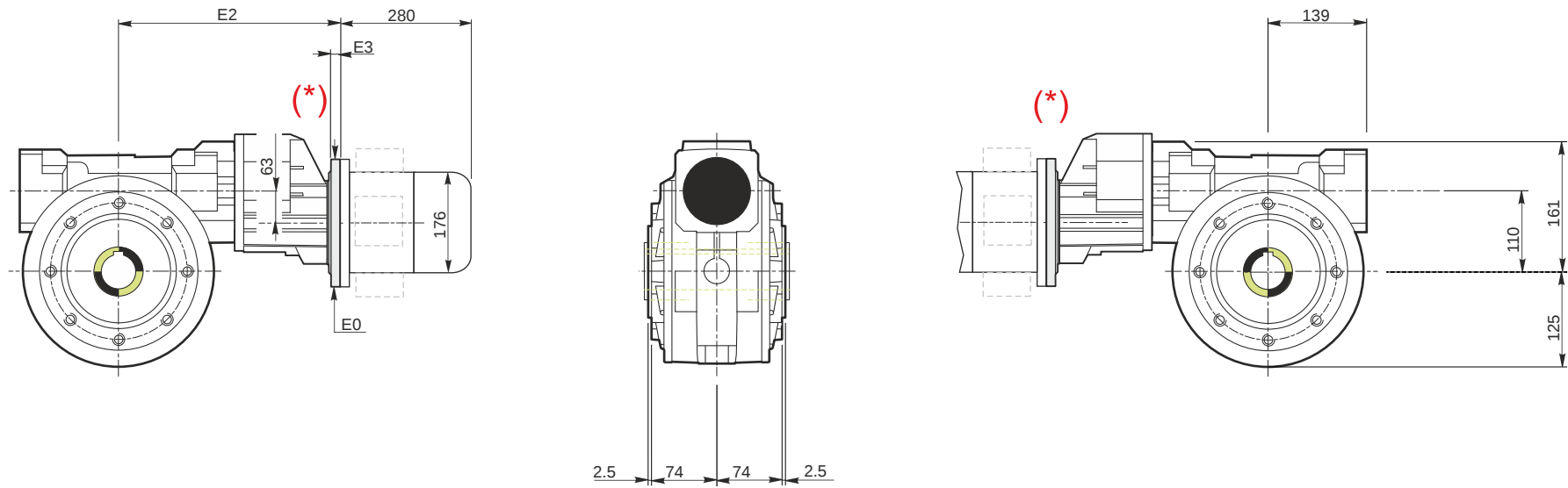

Hollow output shaft

Attachment position

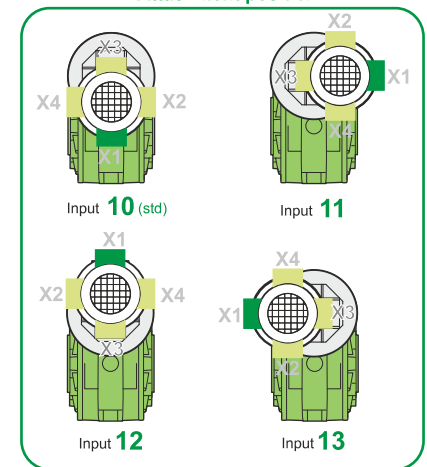

**M RA 100/110 PC 10 174.44 90 B14 AC 42 MT 1.5 kW 90 L4 B14 X3 B3**

### Mounting positions

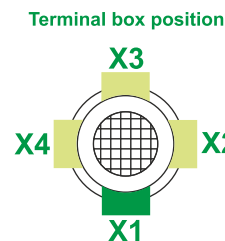
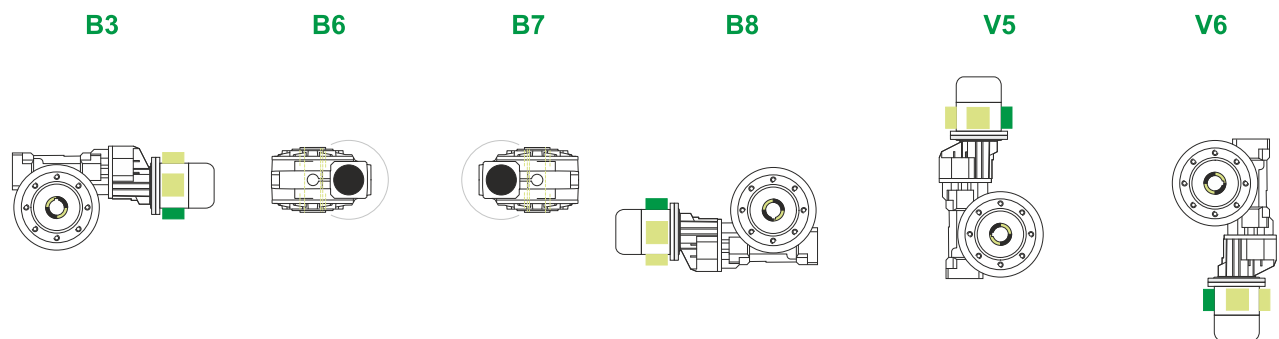

0.2	1
1.5	2



Lubricant type: Long life synthetic oil ISO VG320

### Direction of rotation

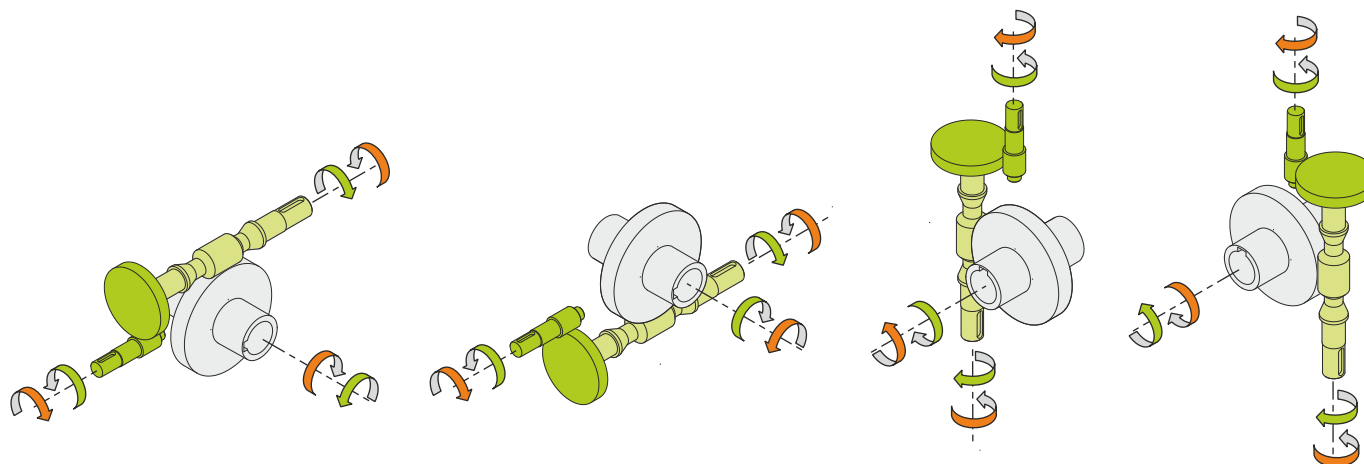

### Weight

Gear unit [kg]	46
Electric motor [kg]	13.5

### Gearing data

Axial module	6.1
Number of starts	1
Lead angle	7° 04'
Pressure angle	20°

### Backdriving

Static self-locking  
Slow back-driving in case of vibrations  
Low dynamic back-driving

**M RA 100/110 PC 10 174.44 90 B14 AC 42 MT 1.5 kW 90 L4 B14 X3 B3**