

Input data

System of measurement		Metric
Input type		Gear motor
Input speed	[rpm]	1400
Output speed	[rpm]	11.11
Ratio (i=)		126
Frequency	[Hz]	50
Input options		IEC
Requested input power	[kW]	3
Service factor		1
Rated Power P1	[kW]	2.93

Output data

Gear unit	M RA 100/130 PC 10 126 100 B14 AC 48 MT 3 kW 100 B4 B14 X3 B3
------------------	--

Type		RA - Worm speed reducers
Input type		M
Size		100/130
Ratio (i=)		126
Gearbox ratio		15.00
Pre-stage ratio		8.40
Input flange		B14
Mounting position		B3
Input speed	[rpm]	1400
Output speed	[rpm]	11.11
Rated output torque	[Nm]	1882.31
Service Factor		1
Efficiency		0.73

Gear unit configuration

Output shaft		Hollow output shaft
Fixing		Shaft mounting
Version		PC
Attachment position		10

Output radial and axial loads

Ball bearings output radial load	[N]	11900
Taper bearings output radial load	[N]	14500
Ball bearings output axial load	[N]	2380
Taper bearings output axial load	[N]	2900

Accessories

Hollow output shaft		AC 48
---------------------	--	-------

Electric motor

Size		100 B4
Poles		4
Power	[kW]	3

Electric motor configuration

Motor flange		B14
Terminal box position		X3

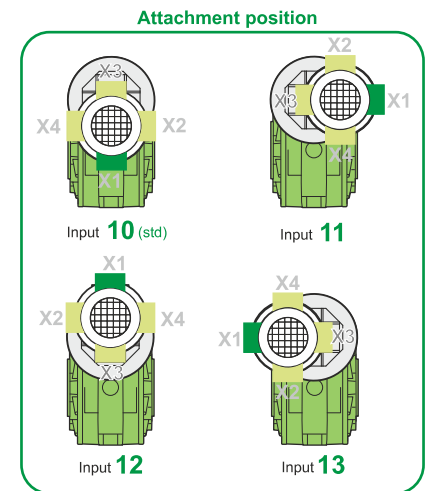
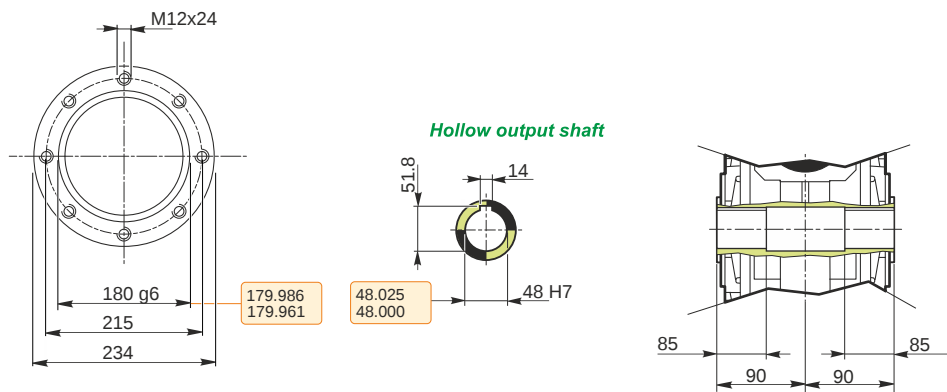
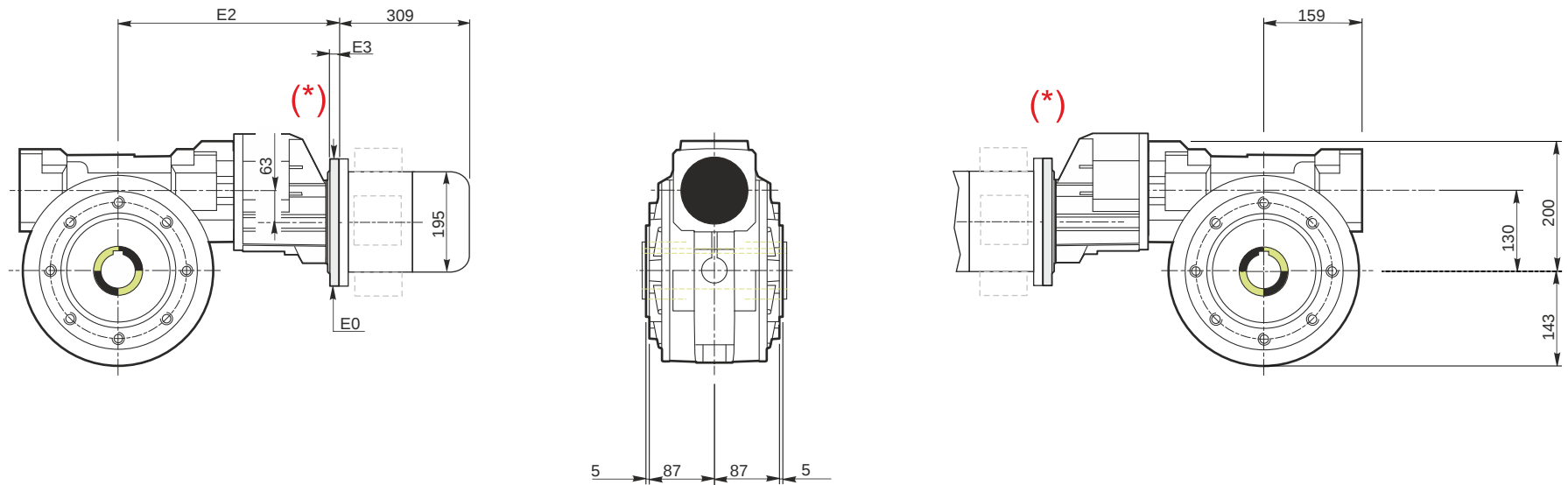

M RA 100/130 PC 10 126 100 B14 AC 48 MT 3 kW 100 B4 B14 X3 B3

Mounting positions

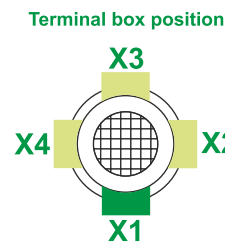
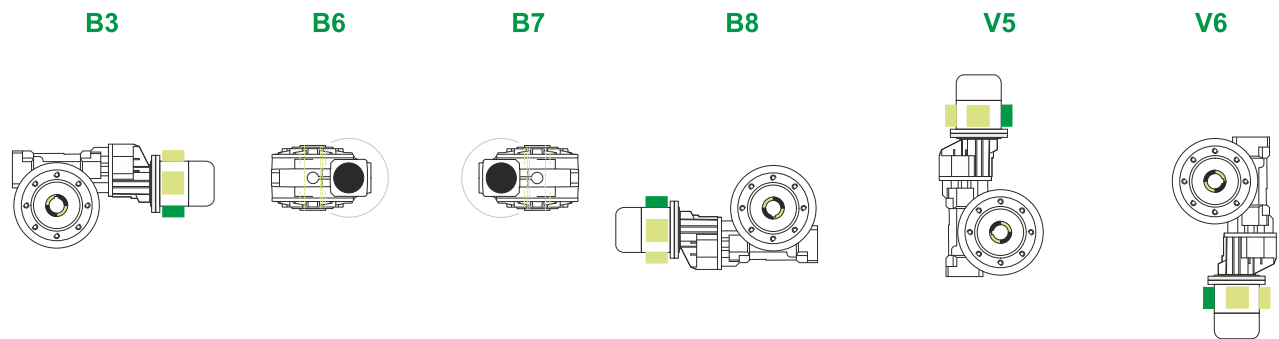

0.2	1
2.75	2



Lubricant type: Long life synthetic oil ISO VG320

Direction of rotation

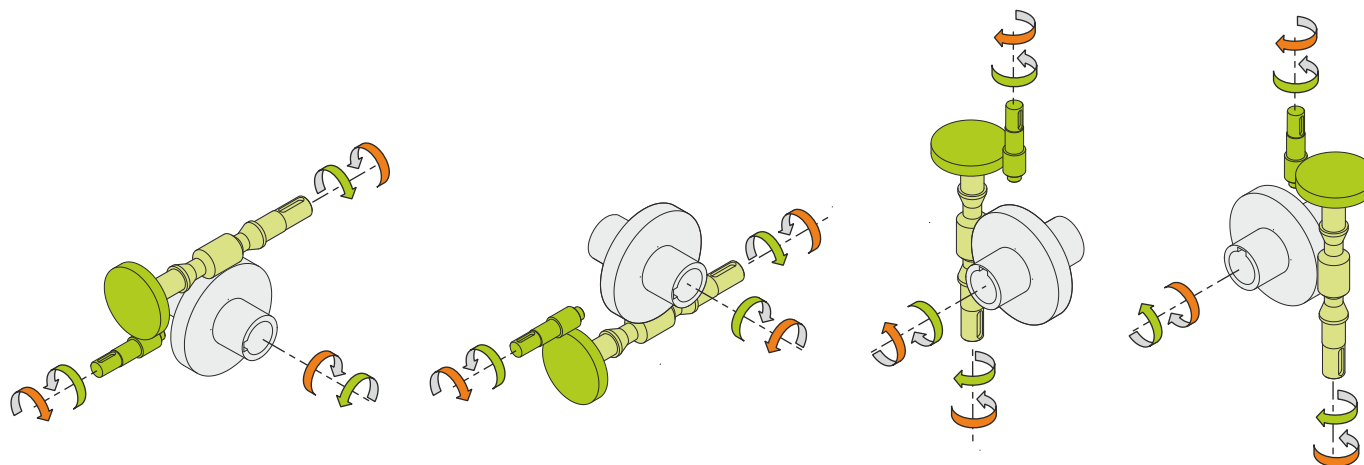

Weight

Gear unit [kg]	64
Electric motor [kg]	21

Gearing data

Axial module	6.85
Number of starts	2
Lead angle	14° 06'
Pressure angle	20°

Backdriving

- Static back-driving
- Quick back-driving
- Dynamic back-driving