

### Input data

System of measurement		Metric
Input type		Gear motor
Input speed	[rpm]	1400
Output speed	[rpm]	40.37
Ratio (i=)		34.68
Frequency	[Hz]	50
Input options		IEC
Requested input power	[kW]	0.13
Service factor		1.2
Rated Power P1	[kW]	0.15

### Output data

<b>Gear unit</b>	<b>M RD 02 B3 H1 34.68 63 B14 AU 20x40 MT 0.13 kW 63 A4 B14 X3</b>
------------------	--

Type		RD - Helical gearboxes
Input type		M
Size		02
Ratio (i=)		34.68
Input flange		B14
Mounting position		H1
Input speed	[rpm]	1400
Output speed	[rpm]	40.37
Rated output torque	[Nm]	29.52
Service Factor		1.2
Efficiency		0.96
Inertia moment	[kgm <sup>2</sup> ]	0.000031

#### Gear unit configuration

Fixing		Feet
Output shaft		AU 20x40

#### Output radial and axial loads

Output radial load	[N]	1430
Output axial load	[N]	286

#### Electric motor

Size		63 A4
Poles		4
Power	[kW]	0.13

#### Electric motor configuration

Motor flange		B14
Terminal box position		X3

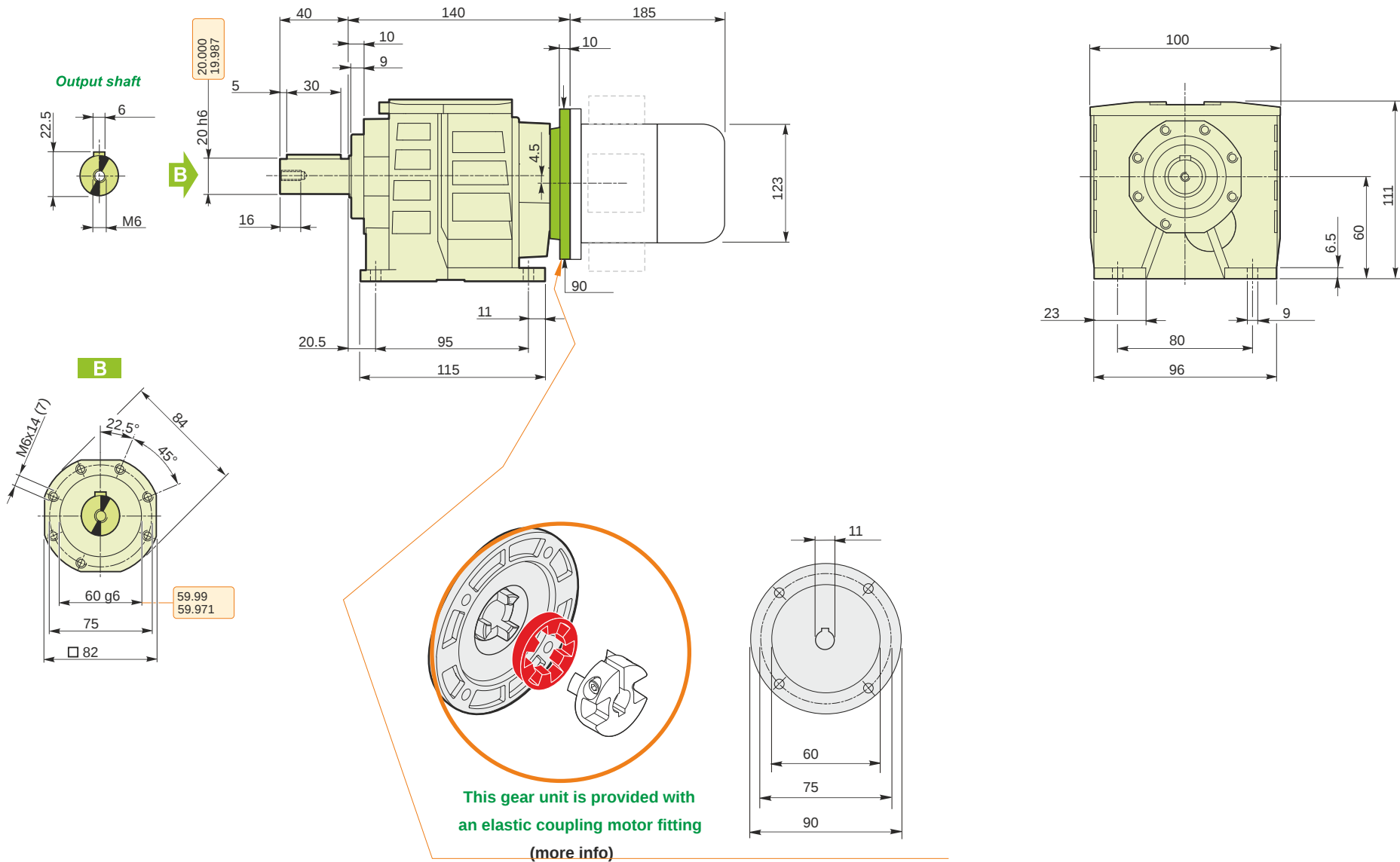

**M RD 02 B3 H1 34.68 63 B14 AU 20x40 MT 0.13 kW 63 A4 B14 X3**

**Mounting positions**

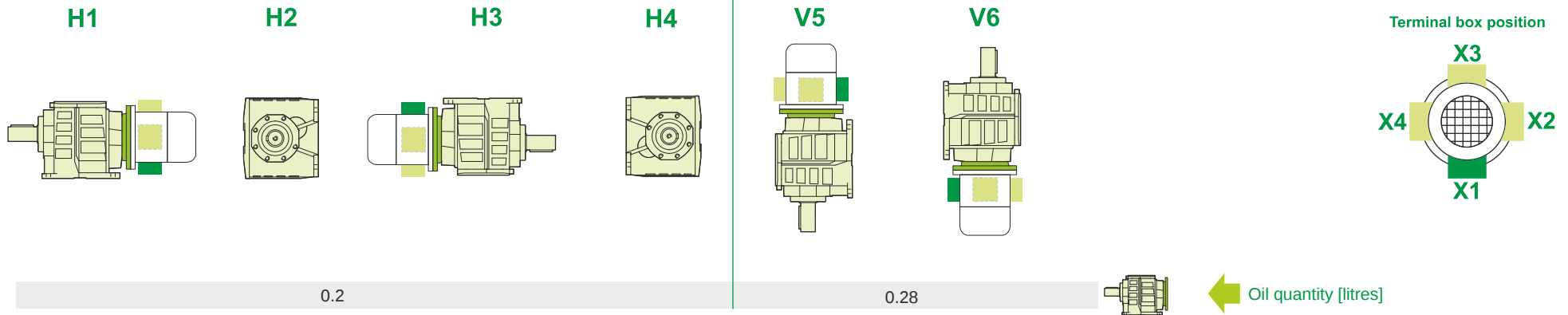

Lubricant type: Long life synthetic oil ISO VG320

**Direction of rotation**

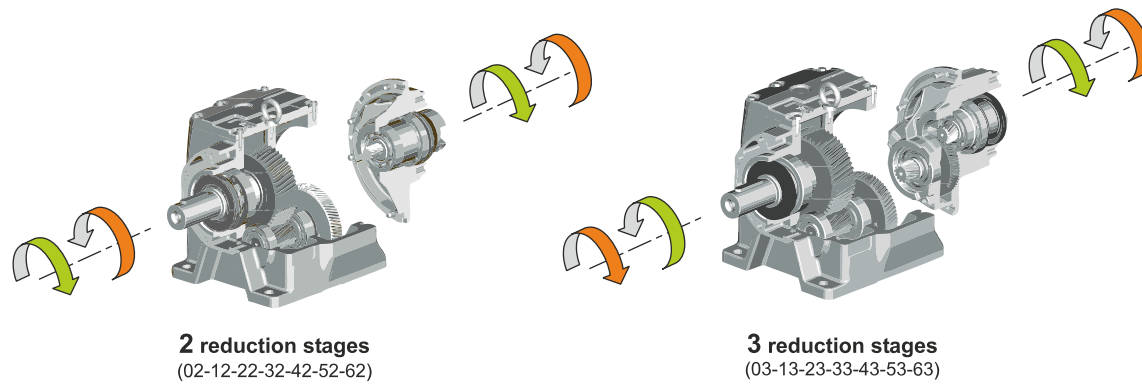

**Weight**

Gear unit [kg]	3
Electric motor [kg]	4.3

**M RD 02 B3 H1 34.68 63 B14 AU 20x40 MT 0.13 kW 63 A4 B14 X3**