

Input data

System of measurement		Metric
Input type		Gear motor
Input speed	[rpm]	1400
Output speed	[rpm]	18.47
Ratio (i=)		75.78
Frequency	[Hz]	50
Input options		IEC
Requested input power	[kW]	0.13
Service factor		0.8
Rated Power P1	[kW]	0.11

Output data

Gear unit	M RD 03 B3 H1 75.78 63 B14 AU 20x40 MT 0.13 kW 63 A4 B14 X3	
------------------	--	--

Type		RD - Helical gearboxes
Input type		M
Size		03
Ratio (i=)		75.78
Input flange		B14
Mounting position		H1
Input speed	[rpm]	1400
Output speed	[rpm]	18.47
Rated output torque	[Nm]	63.17
Service Factor		0.8
Efficiency		0.94
Inertia moment	[kgm ²]	0.000063

Gear unit configuration

Fixing		Feet
Output shaft		AU 20x40

Output radial and axial loads

Output radial load	[N]	1200
Output axial load	[N]	240

Electric motor

Size		63 A4
Poles		4
Power	[kW]	0.13

Electric motor configuration

Motor flange		B14
Terminal box position		X3

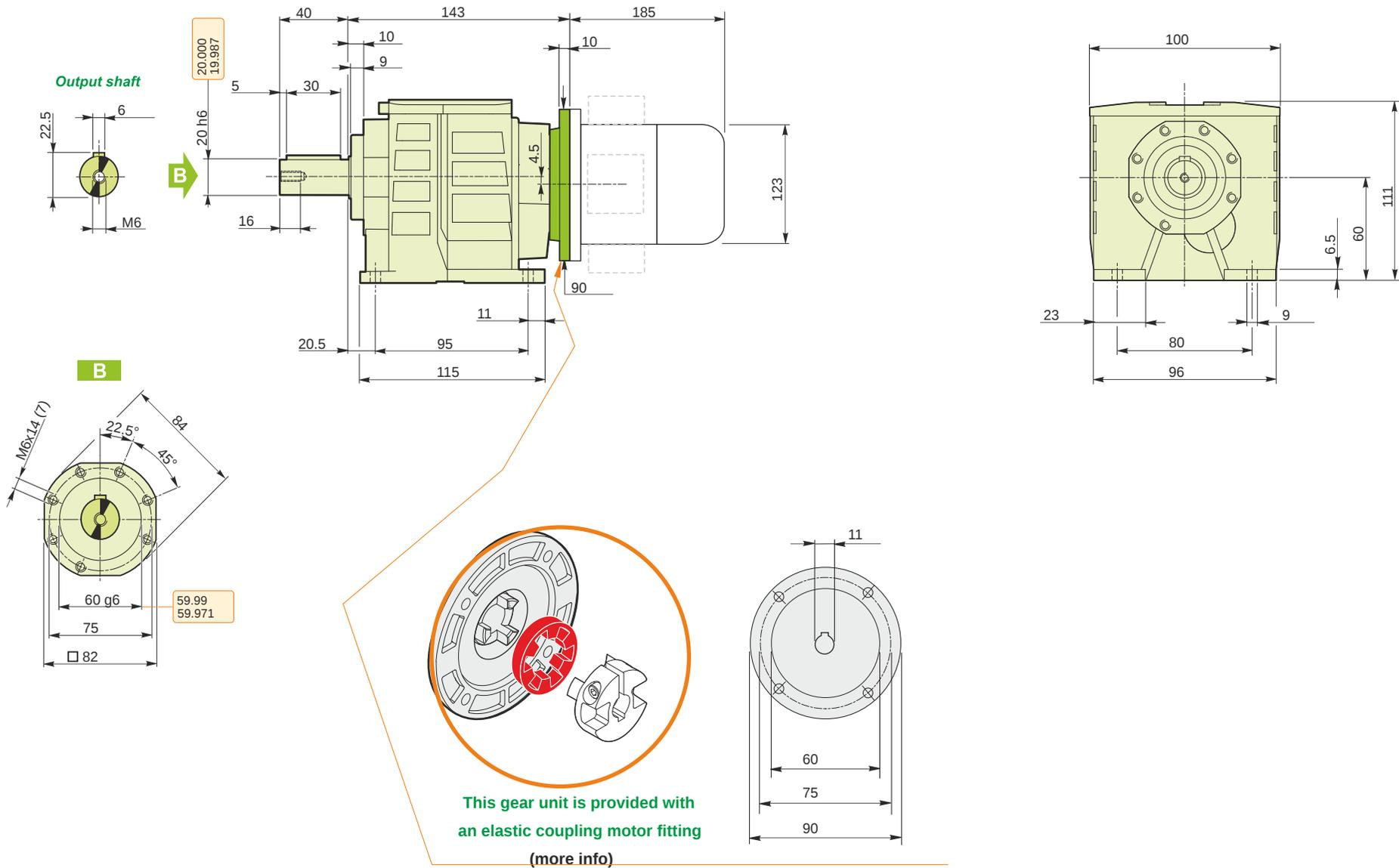

M RD 03 B3 H1 75.78 63 B14 AU 20x40 MT 0.13 kW 63 A4 B14 X3

Mounting positions

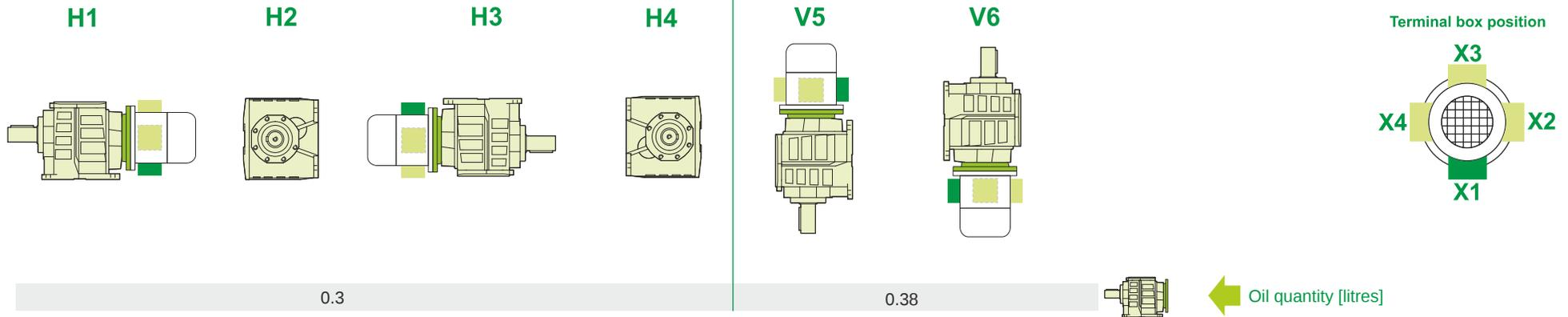

Lubricant type: Long life synthetic oil ISO VG320

Direction of rotation

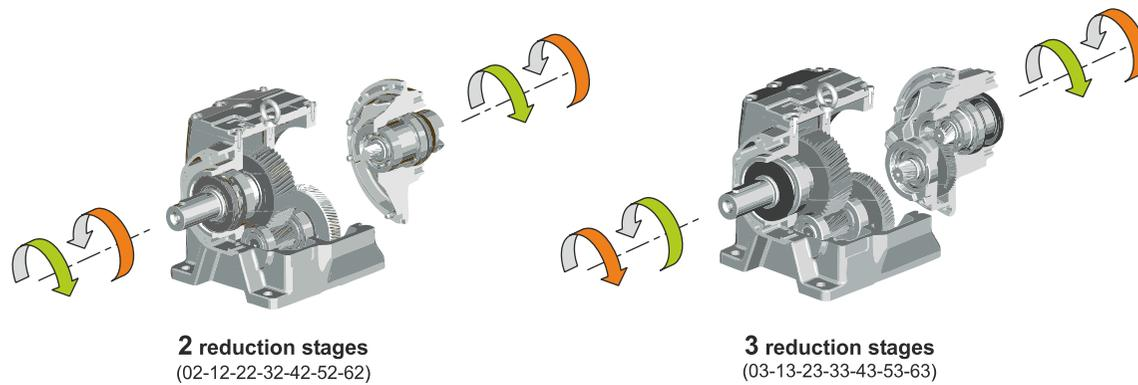

Weight

Gear unit [kg]	3.2
Electric motor [kg]	4.3

M RD 03 B3 H1 75.78 63 B14 AU 20x40 MT 0.13 kW 63 A4 B14 X3