

Input data

System of measurement		Metric
Input type		Gear motor
Input speed	[rpm]	1400
Output speed	[rpm]	276.13
Ratio (i=)		5.07
Frequency	[Hz]	50
Input options		IEC
Requested input power	[kW]	1.5
Service factor		1.1
Rated Power P1	[kW]	1.66

Output data

Gear unit **M RD 12 B3 H1 5.07 90 B14 AU 20x40 MT 1.5 kW 90 L4 B14 X3**

Type		RD - Helical gearboxes
Input type		M
Size		12
Ratio (i=)		5.07
Input flange		B14
Mounting position		H1
Input speed	[rpm]	1400
Output speed	[rpm]	276.13
Rated output torque	[Nm]	49.8
Service Factor		1.1
Efficiency		0.96
Inertia moment	[kgm ²]	0.000067

Gear unit configuration

Fixing		Feet
Output shaft		AU 20x40

Output radial and axial loads

Output radial load	[N]	1600
Output axial load	[N]	320

Electric motor

Size		90 L4
Poles		4
Power	[kW]	1.5

Electric motor configuration

Motor flange		B14
Terminal box position		X3

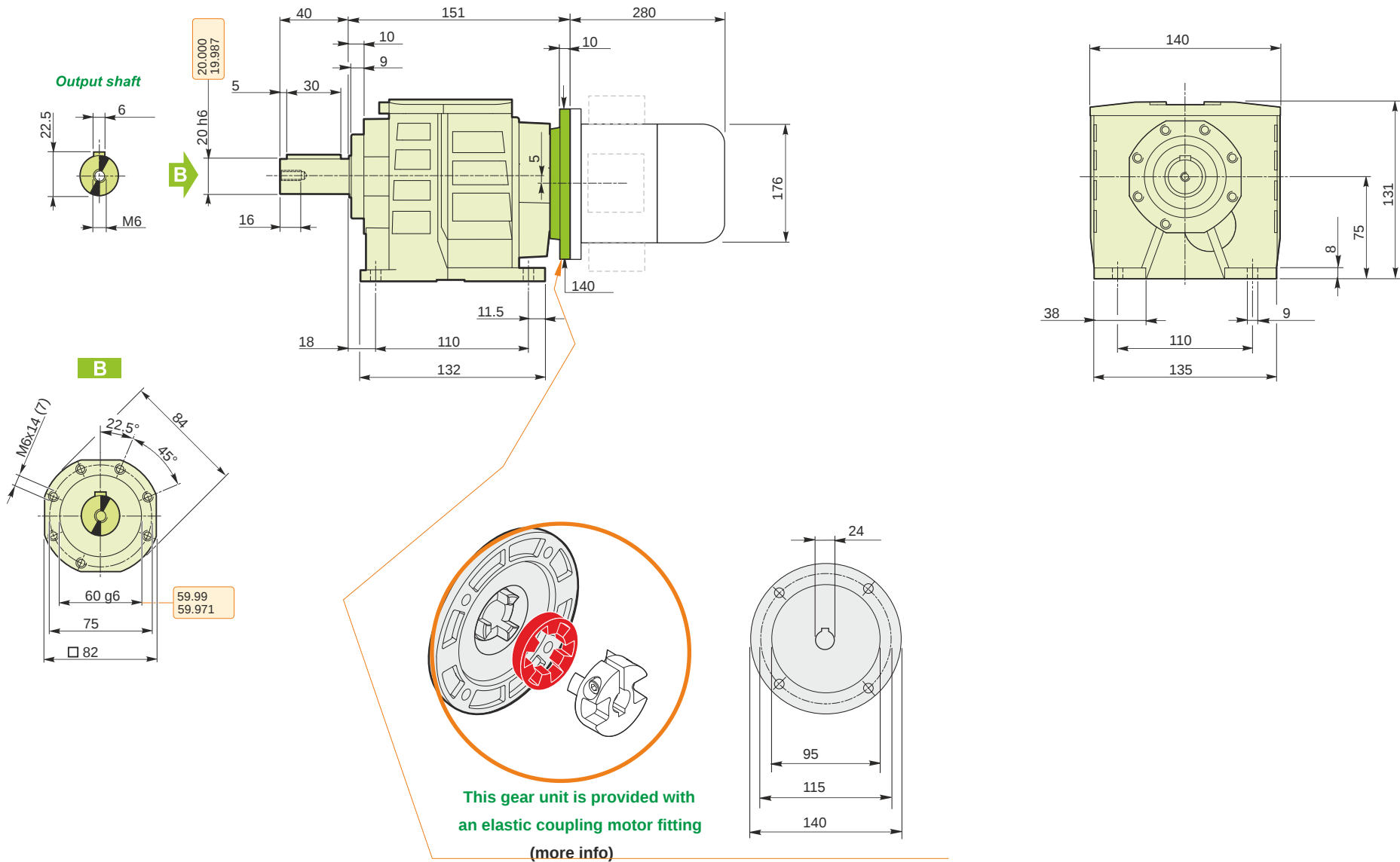

M RD 12 B3 H1 5.07 90 B14 AU 20x40 MT 1.5 kW 90 L4 B14 X3

Mounting positions

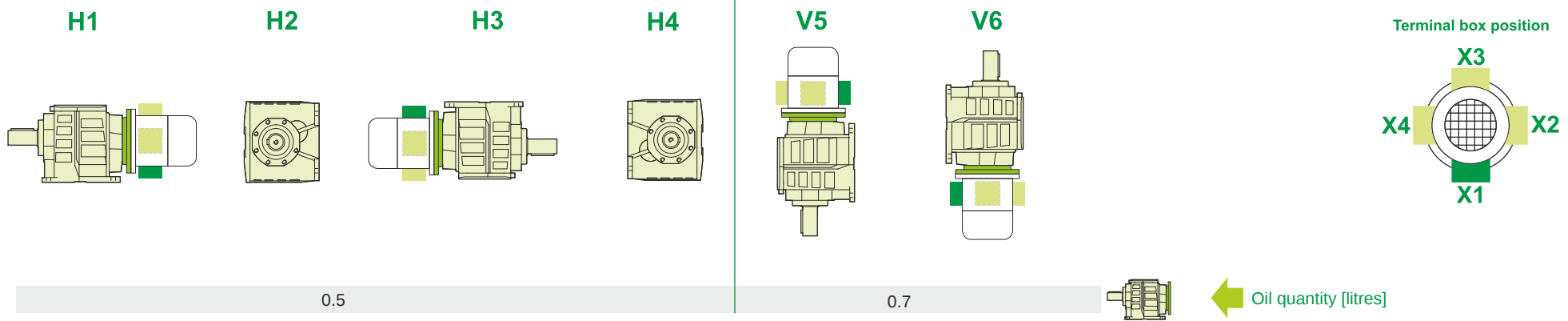

Lubricant type: Long life synthetic oil ISO VG320

Direction of rotation

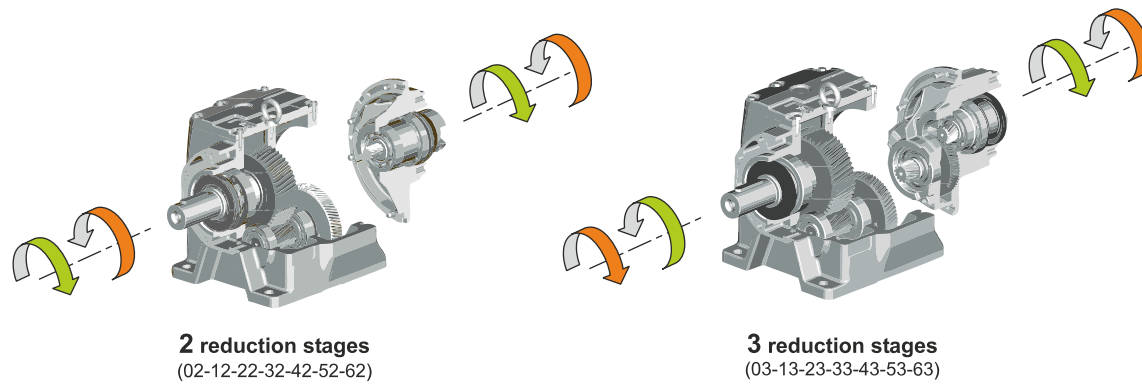

Weight

Gear unit [kg]	4.8
Electric motor [kg]	13.5

M RD 12 B3 H1 5.07 90 B14 AU 20x40 MT 1.5 kW 90 L4 B14 X3